



# LM Stroke

THK General Catalog

## A Product Descriptions

<b>LM Stroke Models ST, ST-B and STI..</b>	<b>A5-2</b>
• Structure and Features .....	A5-2
• Types and Features .....	A5-3
• Rated Load and Nominal Life .....	A5-4
• Table of Equivalent Factors .....	A5-7
• Accuracy Standards .....	A5-8
• Fit .....	A5-8
• ST Shaft .....	A5-9
• Installation of the ST Shaft .....	A5-9
 <b>Dimensional Drawing, Dimensional Table</b>	
Models ST / ST-B .....	A5-10
Models ST...UU/ST...UUB.....	A5-14
 <b>Miniature Stroke Model MST .....</b>	<b>A5-18</b>
• Structure and Features .....	A5-18
• Fit .....	A5-19
• Travel Distance of the Ball Cage .....	A5-19
 <b>Dimensional Drawing, Dimensional Table</b>	
Model MST .....	A5-20
 <b>Die-setting Ball Cage Models KS and BS..</b>	<b>A5-22</b>
• Structure and Features .....	A5-22
• Rated Load and Service Life.....	A5-22
• Fit .....	A5-23
• Installation of the Ball Cage.....	A5-23
 <b>Dimensional Drawing, Dimensional Table</b>	
Models KS / BS .....	A5-24
 <b>Model No. ....</b>	<b>A5-25</b>
• Model Number Coding .....	A5-25
 <b>Precautions on Use .....</b>	<b>A5-26</b>

## B Support Book (Separate)

<b>LM Stroke Models ST, ST-B and STI..</b>	<b>B5-2</b>
• Structure and Features .....	B5-2
• Types and Features .....	B5-3
• Rated Load and Nominal Life .....	B5-4
• Accuracy Standards .....	B5-8
• Fit .....	B5-8
• ST Shaft .....	B5-9
• Installation of the ST Shaft .....	B5-9
 <b>Miniature Stroke Model MST .....</b>	<b>B5-10</b>
• Structure and Features .....	B5-10
• Fit .....	B5-11
• Travel Distance of the Ball Cage .....	B5-11
 <b>Die-setting Ball Cage Models KS and BS..</b>	<b>B5-12</b>
• Structure and Features .....	B5-12
• Rated Load and Service Life.....	B5-12
• Fit .....	B5-13
• Installation of the Ball Cage.....	B5-13
 <b>Model No. ....</b>	<b>B5-14</b>
• Model Number Coding .....	B5-14
 <b>Precautions on Use .....</b>	<b>B5-15</b>

# ST

## LM Stroke Models ST, ST-B and STI

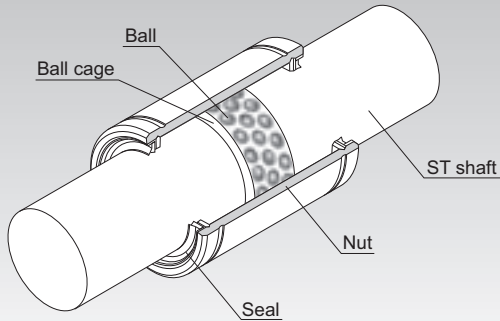

Fig.1 Structure of LM Stroke Model ST

## Structure and Features

Model ST has a ball cage and balls both incorporated into a precision-ground cylindrical nut as shown in Fig.1. The balls are arranged in zigzags so as to evenly receive a load. The ball cage is a drilled cage made of a light alloy with high rigidity, and is capable of high-speed motion. A thrust ring and a snap ring are installed on both sides of the inner surface of the nut to prevent the ball cage from overshooting.

This structure allows rotational motion, reciprocal motion and complex motion with a small friction coefficient. Model ST has a stroke length up to twice the range within which the ball cage can travel. Since high accuracy can be obtained at a low price, this model is used in a broad array of applications such as press die setting, ink roll unit of printing machine, workpiece chuck unit of punching press, press feeder, work head of electric discharge machine, wound roll corrector, spinning and weaving machine, distortion measuring equipment, spindle of optical measuring instrument, and photocopiers.

**[Minimal Friction Coefficient]**

The balls and the ball raceway are in point contact, which causes the smallest rolling loss, and the balls are individually retained in the ball cage. This allows the LM stroke to perform rolling motion at a minimal friction coefficient ( $\mu=0.0006$  to  $0.0012$ ).

**[Compact Design]**

Since it consists only of a thin nut and balls, the outer diameter of the bearing is minimized and a light, space-saving, compact design is achieved.

**[High Accuracy at a Low Price]**

A highly accurate slide unit can be produced at a low price.

---

## Types and Features

---

### Light Load Type Model ST

Model ST is a light load type that allows for a long stroke.

Shaft diameter:  $\phi 6$  to  $\phi 100$

In addition, a type attached with seal is available. Model ST-UU

Specification Table  $\Rightarrow$  **A5-10**

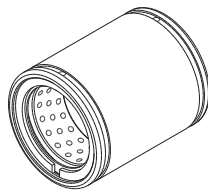

Model ST

### Medium Load Type Model ST-B

It has the same dimensions as model ST, but has a shorter stroke and achieves a rated load twice that of ST.

Shaft diameter:  $\phi 8$  to  $\phi 100$

In addition, a type attached with seal is available. Model ST-UUB

Specification Table  $\Rightarrow$  **A5-10**

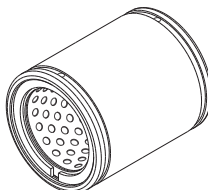

Model ST-B

### Inner Ring Type Model STI

If the LM shaft cannot be hard quenched, STI allows an inner ring to be incorporated. The inner ring is available build-to-order.

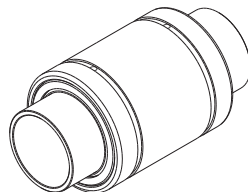

Model STI

---

## Rated Load and Nominal Life

---

### [Load Rating]

The basic load ratings for model ST are indicated in the respective specification tables.

### [Nominal Life]

The nominal life of model ST is obtained using the following equation.

$$L = \left( \frac{f_H \cdot f_T \cdot f_C}{f_W} \cdot \frac{C}{P_C} \right)^3$$

- L : Nominal life (rotating  $10^6$  times)  
(The total number of revolutions that 90% of a group of identical LM strokes independently operating under the same conditions can achieve without showing flaking)
- C : Basic dynamic load rating (N)
- $P_C$  : Calculated radial load (N)
- $f_H$  : Hardness factor (see Fig.2 on **A5-6**)
- $f_T$  : Temperature factor (see Fig.3 on **A5-6**)
- $f_C$  : Contact factor (see Table1 on **A5-7**)
- $f_W$  : Load factor (see Table2 on **A5-7**)

### ● When a Moment Load is Applied to a Single Nut

When a moment load is applied to a single nut, calculate the equivalent radial load from the moment.

$$P_u = K \cdot M$$

- $P_u$  : Equivalent radial load (N)  
(with moment load)
- K : Equivalent factor  
(see Table3 to Table4 on **A5-7**)
- M : Applied moment (N-mm)
- $P_u$  is assumed to be within the Basic Static Load Rating ( $C_0$ ).

### ● When a Moment Load and a Radial Load are Simultaneously Applied

When a moment and a radial load are applied simultaneously, calculate the service life based on the sum of the radial load and the equivalent radial load.

### [Calculating the Service Life Time]

When the nominal life (L) has been obtained, if the number of revolutions per minute and the number of reciprocations per minute are constant, the service life time is obtained using the following equation.

#### ● For Rotating Motion or Complex Motion

$$L_h = \frac{10^6 \times L}{60 \sqrt{(dm \cdot n)^2 + (10 \times \alpha \cdot \ell_s \cdot n_1)^2} / dm}$$

#### ● For Reciprocating Motion

$$L_h = \frac{10^6 \times L}{60 \times 10 \times \alpha \cdot \ell_s \cdot n_1 / (\pi \cdot dm)}$$

$L_h$	: Service life time	(h)
$n$	: Revolutions per minute	( $\text{min}^{-1}$ )
$n_1$	: Number of reciprocations per minute	( $\text{min}^{-1}$ )
$\ell_s$	: Stroke length	(mm)
$dm$	: Pitch circle diameter ( $dm \doteq 1.15 \times dr$ )	(mm)
$dr$	: Ball inscribed bore diameter	(mm)
$\alpha$	: Factor for cage material ( $\alpha=0.7$ )	

### [Tolerance Value in Rotation and Reciprocating Speed]

The permissible speed limit of model ST is obtained using the following equation.

$$DN \geq dm \cdot n + 10 \times l_s \cdot n_1$$

For the DN value above, the following value applies as a standard value.

For oil lubrication  $DN=600000$

For grease lubrication  $DN=300000$

However, the following points must be taken into account.

$n \leq 5000$

$l_s \cdot n_1 \leq 50000$

#### ● $f_H$ : Hardness Factor

To maximize the load capacity of model ST, the hardness of the raceways needs to be between 58 to 64 HRC.

If the hardness is lower than this range, the basic dynamic load rating and the basic static load rating decrease. Therefore, it is necessary to multiply each rating by the respective hardness factor ( $f_H$ ).

Normally,  $f_H=1.0$  since model ST has sufficient hardness.

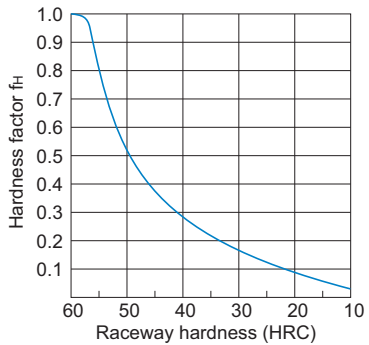

Fig.2 Hardness Factor ( $f_H$ )

#### ● $f_T$ : Temperature Factor

If the temperature of the environment surrounding the operating model ST exceeds 100°C, take into account the adverse effect of the high temperature and multiply the basic load ratings by the temperature factor indicated in Fig.3.

Note) If the environment temperature exceeds 80°C, contact THK.

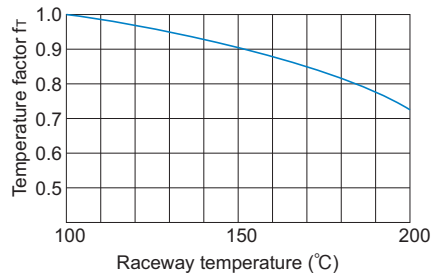

Fig.3 Temperature Factor ( $f_T$ )

### ● $f_c$ : Contact Factor

When multiple nuts of model ST are used in close contact with each other, their linear motion is affected by moments and mounting accuracy, making it difficult to achieve uniform load distribution. In such applications, multiply the basic load rating (C) and ( $C_0$ ) by the corresponding contact factor in Table1.

Note) If uneven load distribution is expected in a large machine, take into account the respective contact factor indicated in table 1.

Table1 Contact Factor ( $f_c$ )

Number of nuts in close contact with each other	Contact factor $f_c$
2	0.81
3	0.72
4	0.66
5	0.61
Normal use	1

### ● $f_w$ : Load Factor

In general, reciprocating machines tend to involve vibrations or impact during operation. It is extremely difficult to accurately determine vibrations generated during high-speed operation and impact during frequent start and stop. Therefore, when speed and vibrations have a significant influence, divide the basic dynamic load rating (C or  $C_0$ ), by the corresponding load factor in Table2 of empirically obtained data.

Table2 Load Factor ( $f_w$ )

Vibrations/impact	Speed (V)	$f_w$
Faint	Very low $V \leq 0.25\text{m/s}$	1 to 1.2
Weak	Slow $0.25 < V \leq 1\text{m/s}$	1.2 to 1.5
Medium	Medium $1 < V \leq 2\text{m/s}$	1.5 to 2
Strong	High $V > 2\text{m/s}$	2 to 3.5

## Table of Equivalent Factors

Table3 Equivalent Factor of Model ST

Model No.	Equivalent factor: K
	Single nut
ST 6	0.726
ST 8	0.721
ST 10	0.489
ST 12	0.421
ST 16	0.408
ST 20	0.419
ST 25	0.42
ST 30	0.28
ST 35	0.285
ST 40	0.252
ST 45	0.251
ST 50	0.207
ST 55	0.206
ST 60	0.206
ST 70	0.206
ST 80	0.186
ST 90	0.185
ST 100	0.185

Table4 Equivalent Factor of Model ST-B

Model No.	Equivalent factor: K
	Single nut
ST 8B	0.444
ST 10B	0.301
ST 12B	0.259
ST 16B	0.251
ST 20B	0.258
ST 25B	0.257
ST 30B	0.171
ST 35B	0.175
ST 40B	0.154
ST 45B	0.154
ST 50B	0.127
ST 55B	0.127
ST 60B	0.127
ST 70B	0.127
ST 80B	0.114
ST 90B	0.114
ST 100B	0.114

## Accuracy Standards

The tolerance value in inscribed bore diameter (dr), nut outer diameter (D) and nut length (L) is indicated in the corresponding specification table.

The end of the nut may be deformed due to tension of the snap ring. Therefore, when measuring the nut outer diameter, it is necessary to calculate the measurement range using the following equation, and obtain the average diameter value within the range.

The tolerance value in the nut outer diameter is equal to the calculated average value of the maximum diameter and the minimum diameter obtained through two-point measurement of the outer diameter.

$$W = 4 + \frac{L}{8}$$

W : Length out of the measurement range (mm)  
 L : Nut length (mm)

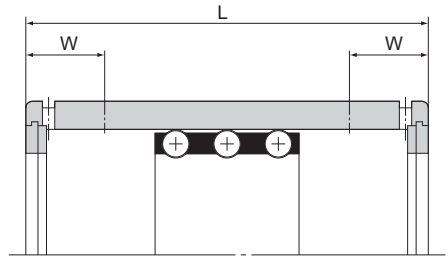

Fig.4 Measurement Range of the Nut

## Fit

In theory, the ball cage of model ST moves in the same direction as the ST shaft by 1/2 of the shaft (or nut). However, to minimize the travel distance error caused by uneven load distribution or vibrations, it is necessary to reduce the clearance. If high accuracy is required or if the LM Stroke is used on a vertical shaft, we recommend setting the radial clearance between 0 and 10 μm.

Item	Normal conditions	Vertical shaft or high accuracy
ST shaft	k5, m5	n5, p5
Housing	H6, H7	J6, J7



---

## ST Shaft

---

With the ST shaft, used in model ST, balls roll directly on the shaft surface. Therefore, it is necessary to pay much attention to the hardness, surface roughness and dimensional accuracy when manufacturing it.

Since the hardness of the ST shaft has especially large impact on the service life, use much care in selecting a material and heat treatment method.

THK also manufactures high-quality ST shafts. Contact us for details.

### [Material]

Generally, the following materials are used as suitable for surface hardening through induction-hardening.

- SUJ2 (JIS G 4805: high-carbon chromium bearing steel)
- SK3 to 6 (JIS G 4401: carbon tool steel)
- S55C (JIS G 4051: carbon steel for machine structural use)

### [Hardness]

We recommend surface hardness of 58 HRC ( $\approx$ 653 HV) or higher. The depth of the hardened layer is determined by the shaft diameter; we recommend approximately 2 mm for general use.

The ST shaft can have a hardened inner ring attached on the shaft raceway.

### [Surface Roughness]

To achieve smooth motion, the surface is normally finished to 0.40a or less. If higher wear resistance is required, finish the surface to 0.20a or less.

---

## Installation of the ST Shaft

---

To install the ST shaft, drive it in to the designated depth. If the clearance is negative, a large driving force is required. However, do not forcibly hammer the shaft. Instead, apply a lubricant on the ST shaft first, and then gradually drive it in with a slight back action.

# Models ST / ST-B

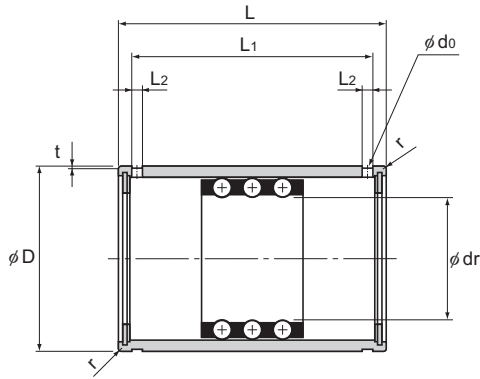

Model ST  
(For light load)

Model No.	Maximum stroke	Inscribed bore diameter				Outer diameter	
		dr	Tolerance	D	Tolerance		
		ST 6	14	6	+0.018 +0.010	12	0 -0.008
ST 8 ST 8B	24 8	8	+0.022 +0.013	15			
ST 10 ST 10B	30 8	10		+0.027 +0.016	19	0 -0.009	
ST 12 ST 12B	32 8	12	23				
ST 16 ST 16B	40 16	16	28				
ST 20 ST 20B	54 28	20	+0.033 +0.020	32	0 -0.011		
ST 25 ST 25B	54 28	25		37			
ST 30 ST 30B	82 44	30		45			
ST 35 ST 35B	92 54	35	+0.041 +0.025	52	0 -0.013		

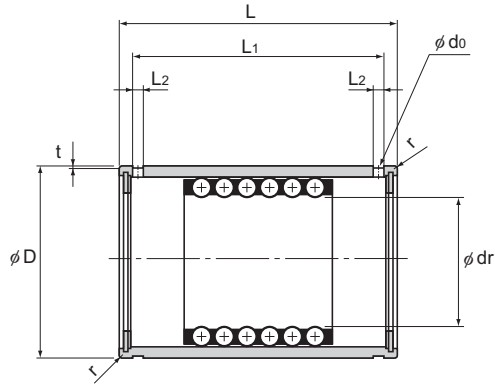

Model ST-B  
(For medium load)

Unit: mm

	Length		L <sub>1</sub>	L <sub>2</sub>	t	d <sub>o</sub>	r	Basic dynamic load rating	Basic static load rating	Mass
	L	Tolerance						C kN	C <sub>0</sub> kN	g
	19	0 -0.2	13.5	1.1	0.25	—	0.3	0.98	0.23	8
	24		20.1	1.5	0.5	1.5	0.5	0.98 2.06	0.27 0.55	16.4 17.6
	30		25.7	1.5	0.5	1.5	0.5	2.35 4.61	0.62 1.27	31.5 34.5
	32		27.5	1.5	0.5	1.5	0.5	4.02 8.14	1.08 2.25	47 53.5
	37		32.1	1.5	0.5	1.5	0.5	4.02 8.04	1.27 2.65	77 85
	45		39.8	2	0.5	2	0.5	4.12 8.33	1.57 3.24	109 120
	45	0 -0.3	39.8	2	0.5	2	1	4.12 8.14	1.76 3.63	128 142
	65		58.5	2.5	0.5	2.5	1	9.31 18.7	4.12 8.14	240 275
	70		63.5	2.5	0.7	2.5	1.5	9.41 18.7	4.51 9.02	370 410

# Models ST / ST-B

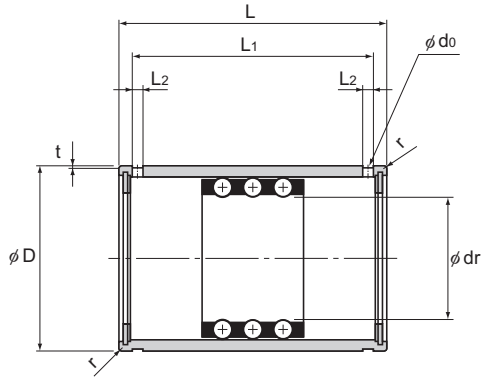

Model ST  
(For light load)

Model No.	Maximum stroke	Inscribed bore diameter			
		Inscribed bore diameter		Outer diameter	
		dr	Tolerance	D	Tolerance
ST 40 ST 40B	108 66	40	+0.041 +0.025	60	0 -0.013
ST 45 ST 45B	108 66	45		65	
ST 50 ST 50B	138 88	50		72	
ST 55 ST 55B	138 88	55	+0.049 +0.030	80	0 -0.015
ST 60 ST 60B	138 88	60		85	
ST 70 ST 70B	138 88	70		95	
ST 80 ST 80B	132 76	80		110	
ST 90 ST 90B	132 76	90	+0.058 +0.036	120	0 -0.018
ST 100 ST 100B	132 76	100		130	

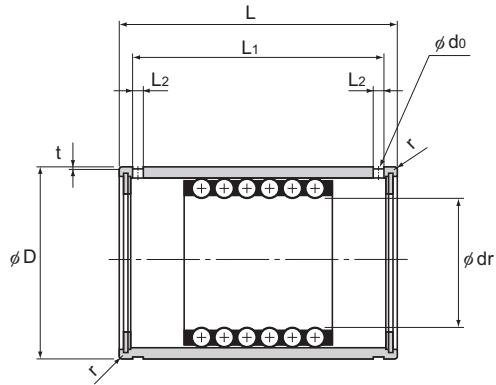

Model ST-B  
(For medium load)

Unit: mm

								Basic dynamic load rating	Basic static load rating	Mass
Length		L <sub>1</sub>	L <sub>2</sub>	t	d <sub>0</sub>	r	C kN	C <sub>0</sub> kN	g	
L	Tolerance									
80	0 -0.3	73.3	2.5	0.7	2.5	1.5	12.5 25	6.18 12.4	570 635	
80		73.3	2.5	0.7	2.5	1.5	12.6 25.2	6.76 13.5	625 695	
100		92.4	3	1	3	1.5	16.3 32.5	8.82 17.7	910 1020	
100		92.4	3	1	3	2	16.6 33	9.71 19.3	1270 1380	
100	0 -0.4	92.4	3	1	3	2	16.8 33.6	10.5 21	1360 1480	
100		92.4	3	1	3	2	16.9 33.8	11.7 23.3	1530 1670	
100		92	3	1.5	3	2	21.3 42.5	15.3 30.6	2220 2430	
100		92	3	1.5	3	2	21.7 43.3	16.9 33.7	2440 2670	
100		92	3	1.5	3	2	22 43.9	18.3 36.8	2670 2910	

# Models ST...UU/ST...UUB

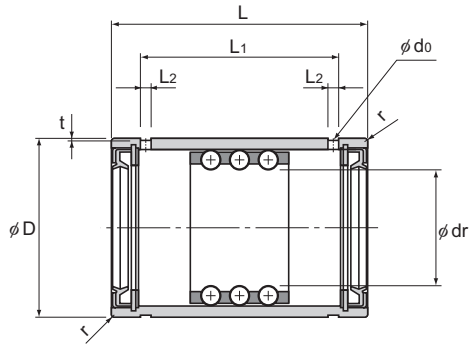

Model ST...UU  
(For light load)

Model No.	Maximum stroke	Inscribed bore diameter		Outer diameter	
		dr	Tolerance	D	Tolerance
		ST 8UU	14	8	+0.022 +0.013
ST 10UU	16	10	19		
ST 12UU	17	12	+0.027 +0.016	23	0 -0.009
ST 16UU	24	16		28	
ST 20UU ST 20UUB	32 12	20	+0.033 +0.020	32	0 -0.011
ST 25UU ST 25UUB	32 12	25		37	
ST 30UU ST 30UUB	65 27	30		45	
ST 35UU ST 35UUB	75 37	35	+0.041 +0.025	52	0 -0.013
ST 40UU ST 40UUB	91 49	40		60	
ST 45UU ST 45UUB	91 49	45		65	

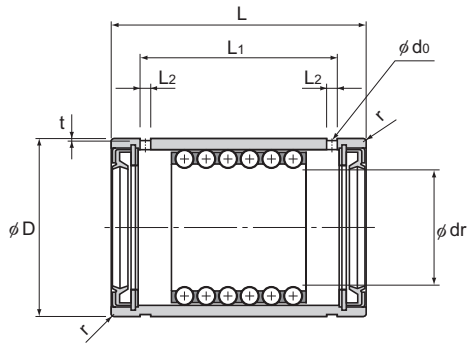

Model ST···UUB  
(For medium load)

Unit: mm

Length								Basic dynamic load rating C kN	Basic static load rating C <sub>0</sub> kN	Mass g
L	Tolerance	L <sub>1</sub>	L <sub>2</sub>	t	d <sub>0</sub>	r				
24	0 -0.2	15.3	1.5	0.5	1.5	0.5	0.98	0.27	17	
30		18.5	1.5	0.5	1.5	0.5	2.35	0.62	31	
32		20.1	1.5	0.5	1.5	0.5	4.02	1.08	49	
37		24.1	1.5	0.5	1.5	0.5	4.02	1.27	80	
45		30.8	2	0.5	2	0.5	4.12 8.33	1.57 3.24	112 125	
45	0 -0.3	30.8	2	0.5	2	1	4.12 8.14	1.76 3.63	132 145	
65		50.1	2.5	0.5	2.5	1	9.31 18.7	4.12 8.14	245 280	
70		55.1	2.5	0.7	2.5	1.5	9.41 18.7	4.51 9.02	375 420	
80		64.9	2.5	0.7	2.5	1.5	12.5 25	6.18 12.4	580 640	
80		64.9	2.5	0.7	2.5	1.5	12.6 25.2	6.76 13.5	635 705	

# Models ST...UU/ST...UUB

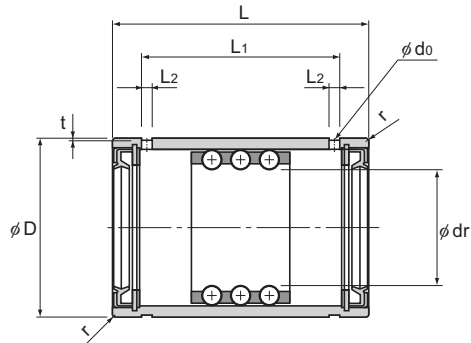

Model ST...UU  
(For light load)

Model No.	Maximum stroke	Inscribed bore diameter				Outer diameter	
		dr	Tolerance	D	Tolerance		
						ST 50UU ST 50UUB	120 70
ST 55UU ST 55UUB	120 70	55	+0.049 +0.030	80			
ST 60UU ST 60UUB	120 70	60		85	0 -0.015		
ST 70UU ST 70UUB	120 70	70		95			
ST 80UU ST 80UUB	114 58	80		110			
ST 90UU ST 90UUB	114 58	90	+0.058 +0.036	120		0 -0.018	
ST 100UU ST 100UUB	114 58	100	130				



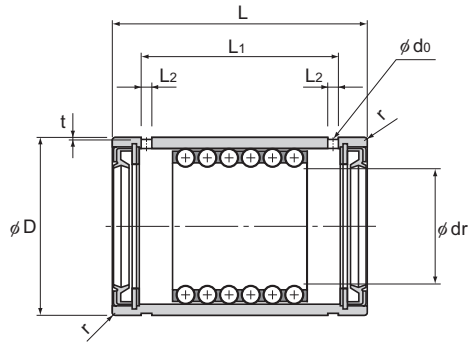

Model ST...UUB  
(For medium load)

Unit: mm

	Length		L <sub>1</sub>	L <sub>2</sub>	t	d <sub>0</sub>	r	Basic dynamic load rating C kN	Basic static load rating C <sub>0</sub> kN	Mass g
	L	Tolerance								
	100	0 -0.3	83.4	3	1	3	1.5	16.3 32.5	8.82 17.7	920 1030
	100		83.4	3	1	3	2	16.6 33	9.71 19.3	1280 1400
	100	0 -0.4	83.4	3	1	3	2	16.8 33.6	10.5 21	1370 1490
	100		83.4	3	1	3	2	16.9 33.8	11.7 23.3	1540 1680
	100		83	3	1.5	3	2	21.3 42.5	15.3 30.6	2240 2450
	100		83	3	1.5	3	2	21.7 43.3	16.9 33.7	2470 2700
	100		83	3	1.5	3	2	22 43.9	18.3 36.8	2700 2940
	100		83	3	1.5	3	2	22 43.9	18.3 36.8	2700 2940

# MST

## Miniature Stroke Model MST

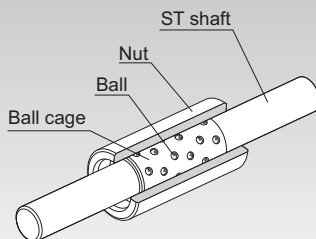

Fig.1 Structure of Miniature Stroke Model MST

## Structure and Features

Model MST consists of an ST shaft, ball cage and nut. These components can freely be combined according to the application. The sectional shape is small, the clearance is minimal and the motion is extremely light and smooth. Accordingly, model MST can be used in a variety of small, precision measuring equipment such as optic measuring instrument's spindle, pen plotter, OA equipment, computer terminals, automatic scale, digital length measuring machine and solenoid valve.

### [Highly Accurate Bearing]

Precision steel balls (sphericity in mutual difference: 0.0003 mm) compliant with JIS B 1501 are incorporated in a copper alloy ball cage to ensure high accuracy. The ball cage serves to prevent the balls from falling off with a unique ball-retaining design.

### [Highly Durable Bearing]

The nut of the ST shaft uses a selected material, and is heat-treated and ground. In addition, the raceways are finished with ultra fine finish. The rows of balls are densely arranged in the ball cage, and the balls are placed so that the ball raceways do not overlap with each other. It enables this model to be used over a long period without wear and to demonstrate high durability.

**[Compact Bearing]**

Use of a combination of balls with a 1 mm diameter and a thin nut allows a small sectional shape and space-saving design.

**[Bearing with Extremely Low Frictional Resistance]**

Since the balls are in point-contact with the raceways, rolling loss is minimal and rolling motion with low-friction is achieved.

---

**Fit**

---

The inner surface of the housing must be finished to H6 to H7, and secured with an adhesive after the nut is inserted.

When press fitting is required, mounting the nut to the hole will reduce the inner diameter. Therefore, be sure to check the inner diameter after press fitting the nut and adjust the shaft diameter so that a correct preload is achieved. Also make sure that the preload must not exceed  $-2\mu\text{m}$ .

---

**Travel Distance of the Ball Cage**

---

The ball cage can travel up to 1/2 of the stroke length ( $\ell_s$ ) of the nut or the ST shaft in the same direction.

# Model MST

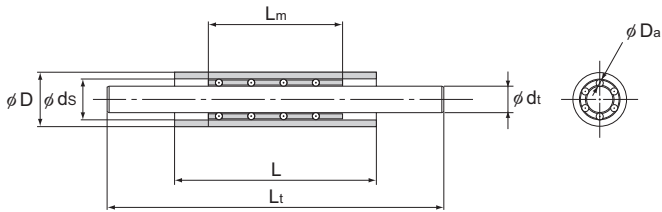

Combined model No.	Ball cage					Nut	
	Model No.	$D_a$	$L_m$ (A)	Permissible load $C_0$ N	Mass g	Model No.	D
MST 3-A•B•C	M3510	1	10	68.6	0.7	S5710	7 <sup>0</sup> -0.006
	M3515		15	98	1.1	S5720	
	M3520		20	137	1.4	S5730	
MST 4-A•B•C	M4610	1	10	78.4	0.9	S6810	8 <sup>0</sup> -0.006
	M4615		15	118	1.4	S6820	
	M4620		20	157	1.9	S6830	
MST 5-A•B•C	M5710	1	10	98	1.1	S71010	10 <sup>0</sup> -0.006
	M5715		15	137	1.7	S71020	
	M5720		20	186	2.3	S71030	
MST 6-A•B•C	M6810	1	10	108	1.2	S81120	11 <sup>0</sup> -0.011
	M6815		15	157	2.0	S81130	
	M6820		20	216	2.6	S81140	

Note) If the radial clearance needs to be zero or below, add symbol "C1" at the end of the model number.

(Example) MST5-203080 C1

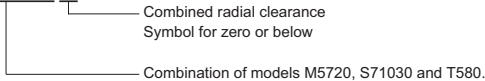

## Model number coding

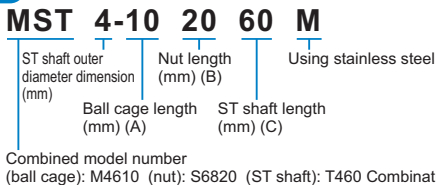

Note) The model numbers of ball cage, nut and ST shaft are indicated in the corresponding specification table.

Unit: mm

Nut			ST shaft				Combined radial clearance $\mu\text{m}$	
$d_s$	L (B)	Mass g	Model No.	$d_i$	$L_i$ (C)	Mass g		
5 $\pm 0.002$	10	1.4	T350 T360	3	0 -0.003	50	2.8	-2 to +5
	20	2.9				60	3.3	
	30	4.5						
6 $\pm 0.002$	10	1.7	T450 T460	4	0 -0.003	50	4.5	-2 to +5
	20	3.6				60	5.6	
	30	5.0						
7 $\pm 0.002$	10	2.9	T550 T580	5	0 -0.003	50	7.1	-2 to +5
	20	6.3				80	12.6	
	30	10.0						
8 $\pm 0.002$	20	7.1	T650 T680	6	0 -0.003	50	10.0	-2 to +5
	30	10.0				80	16.6	
	40	12.6						

LM Stroke

# KS/BS

## Die-setting Ball Cage Models KS and BS

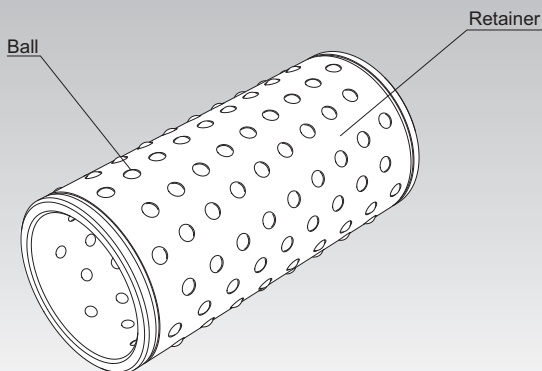

Fig.1 Structure of Die-setting Ball Cage Model KS

### Structure and Features

With models KS and BS, a large number of precision steel balls (sphericity in mutual difference: 0.0005 mm) compliant with JIS B 1501 are incorporated in a lightweight, highly rigid ball cage. The balls are arranged along the circumference of the ball cage in spirals so that the ball raceways do not overlap with each other. It enables these models to be used over a long period without wear and to demonstrate high durability.

In addition, the ball pockets, which hold the balls, are finished with precision and continuously caulked with a unique process, enabling them to prevent the balls from falling. It allows the system to travel smoothly even if the ball cage is longer than the housing.

These ball cages are used in precision press die set, spinning and weaving machine, precision measuring instrument, automatic recorder, medical equipment and various machine tools.

### Rated Load and Service Life

The rated loads of models KS and BS are indicated in the respective specification tables. Their service lives are obtained using the service life equation for LM Stroke model ST on **A5-4**.

## Fit

When using the Die-setting Ball Cage in the guide unit of the guide post of a precision press die set, normally select a negative clearance in order to increase the accuracy and the ball cage rigidity. Table1 shows typical fitting between the hole and the shaft. Select a combination of a hole and a shaft so that the clearance does not exceed the tolerance value of the radial clearance indicated in the specification table.

Table1 Fitting between Holes and Shaft

Tolerance in hole dimensions: D	K5
Dimensional tolerance of the shaft: d	h5

## Installation of the Ball Cage

Fig.2 shows examples of mounting the Die-setting Ball Cage.

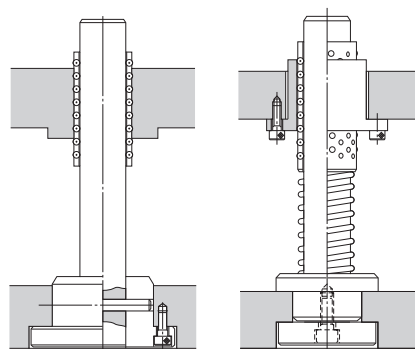
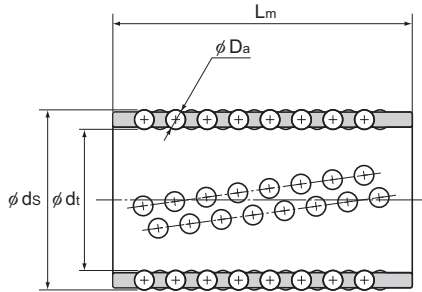

Fig.2 Example of Installation

# Models KS / BS



Unit: mm

Combined model No.	Main dimensions				Radial clearance tolerance $\mu\text{m}$	Basic load rating		Mass g
	$d_t$	$D_a$ (inch)	$d_s$	$L_m$		C kN	$C_0$ kN	
KS 1955	19	3	25	55	-7	10.3	3.82	31.7
BS 1955	19	3.175 (1/8)	25.35	55	-7	11.7	4.22	33.2
KS 2260	22	3	28	60	-7	10.7	4.22	37.6
BS 2260	22	3.175 (1/8)	28.35	60	-7	12.2	4.71	39.1
KS 2565	25	3	31	65	-7	11.7	5	45.4
BS 2565	25	3.175 (1/8)	31.35	65	-7	13.2	5.59	47.1
KS 2870	28	4	36	70	-9	18	7.65	80.4
BS 2870	28	3.969 (5/32)	35.938	70	-9	17.7	7.55	80.0
KS 3275	32	4	40	75	-9	19.7	9.12	96.5
BS 3275	32	3.969 (5/32)	39.938	75	-9	19.3	8.92	96.0
KS 3880	38	5	48	80	-10	25	12	156
BS 3880	38	4.762 (3/16)	47.525	80	-10	22.5	10.9	150

Note) The outer surface of model BS has a groove to help distinguish it from KS.  
Shafts for models KS and BS are also manufactured. Contact THK for details.



## Model Number Coding

Model number configurations differ depending on the model features. Refer to the corresponding sample model number configuration.

### [LM Stroke]

- Models **ST, ST-B, ST···UU and ST···UUB**

**ST20UUB**

Model No.

### [Miniature Stroke]

- Models **M, S, T and MST**

- Ball Cage only
- Nut only
- ST shaft only

**M4610**

Model No.

**S6820**

Model No.

**T460**

Model No.

- Ball cage, nut and ST shaft combinations

<b>MST</b>	<b>4-10</b>	<b>20</b>	<b>60</b>	<b>M</b>
ST shaft outer diameter dimension (mm)	Ball cage length (mm) (A)	Nut length (mm) (B)	ST shaft length (mm) (C)	Using stainless steel

Combined model number  
(ball cage): M4610 (nut): S6820 (ST shaft): T460 Combination of these components

Note) The model numbers of ball cage, nut and ST shaft are indicated in the corresponding specification table.

### [Die-setting Ball Cage]

- Models **KS and BS**

**KS3880**

Model No.

## [Handling]

- (1) Do not disassemble the parts. This will result in loss of functionality.
- (2) Take care not to drop or strike the LM Stroke. Doing so may cause injury or damage. Giving an impact to it could also cause damage to its function even if the product looks intact.
- (3) When handling the product, wear protective gloves, safety shoes, etc., as necessary to ensure safety.

## [Precautions on Use]

- (1) With the model ST LM Stroke, intrusion of foreign matter can cause abnormal wear and reduce service life. If there is a risk of foreign material intruding, use a seal or another protective option suited to the usage conditions and surrounding environment. A highly abrasion-resistant synthetic rubber seal (model ST...UU) and dust-proof felt seal with low seal resistance (model ST...DD) are available for the model ST.
- (2) If foreign material such as cutting chips adheres to the product, replenish the lubricant after cleaning the product.
- (3) Do not use the product at temperature of 80°C or higher. Exposure to higher temperatures may cause the resin/rubber parts to deform/be damaged.
- (4) If the product is used in an environment where cutting chips, coolant, corrosive solvents, water, etc., may enter the product, use bellows, covers, etc., to prevent them from entering the product.
- (5) Micro-strokes tend to obstruct oil film to form on the raceway in contact with the rolling element, and may lead to fretting corrosion. Take consideration using grease offering excellent fretting prevention. It is also recommended that a stroke movement corresponding to the length of the ball cage be made on a regular basis to make sure oil film is formed between the raceway and rolling element.
- (6) Do not use undue force when fitting parts (pin, key, etc.) to the product. This may generate pressure marks on the raceway, leading to loss of functionality.
- (7) Insert the shaft straight through the opening. Inserting the shaft at an angle can introduce foreign matter, damage internal components, or cause balls to fall out.
- (8) Using this product with any balls removed may result in premature damage.
- (9) Please contact THK if any balls fall out; do not use the product if any balls are missing.
- (10) If an attached component is insufficiently rigid or mounted incorrectly, the bearing load will be concentrated at one location and performance will decline significantly. Make sure the housing and base are sufficiently rigid, the anchoring bolts are strong enough, and the component is mounted correctly.

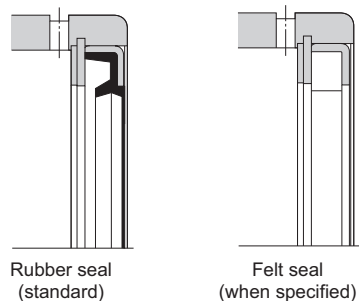

Fig.1 Seals used with the LM Stroke

**[Lubrication]**

- (1) Thoroughly wipe off anti-rust oil and feed lubricant before using the product.
- (2) Do not mix different lubricants. Mixing greases using the same type of thickening agent may still cause adverse interaction between the two greases if they use different additives, etc.
- (3) When using the product in locations exposed to constant vibrations or in special environments such as clean rooms, vacuum and low/high temperature, use the grease appropriate for the specification/environment.
- (4) When lubricating the product, apply grease directly on the raceway and stroke the product several times to let the grease spread inside.
- (5) The consistency of grease changes according to the temperature. Take note that the slide resistance of the LM Stroke also changes as the consistency of grease changes.
- (6) After lubrication, the slide resistance of the LM Stroke may increase due to the agitation resistance of grease. Be sure to perform a break-in to let the grease spread fully, before operating the machine.
- (7) Excess grease may scatter immediately after lubrication, so wipe off scattered grease as necessary.
- (8) The properties of grease deteriorate and its lubrication performance drops over time, so grease must be checked and added properly according to the use frequency of the machine.
- (9) The greasing interval varies depending on the use condition and service environment. Set the final lubrication interval/amount based on the actual machine.
- (10) The model ST LM Stroke can be lubricated with either oil or grease. Select the appropriate option in accordance with the DN value. THK recommends lithium grease no. 2.

**[Storage]**

When storing the LM Stroke, enclose it in a package designated by THK and store it in a room while avoiding high temperature, low temperature and high humidity.

**[Disposal]**

Dispose of the product properly as industrial waste.





# LM Stroke

THK General Catalog

## B Support Book

<b>LM Stroke Models ST, ST-B and STI..</b>	<b>B5-2</b>
• Structure and Features .....	B5-2
• Types and Features .....	B5-3
• Rated Load and Nominal Life .....	B5-4
• Accuracy Standards .....	B5-8
• Fit .....	B5-8
• ST Shaft .....	B5-9
• Installation of the ST Shaft .....	B5-9
<b>Miniature Stroke Model MST .....</b>	<b>B5-10</b>
• Structure and Features .....	B5-10
• Fit .....	B5-11
• Travel Distance of the Ball Cage .....	B5-11
<b>Die-setting Ball Cage Models KS and BS..</b>	<b>B5-12</b>
• Structure and Features .....	B5-12
• Rated Load and Service Life.....	B5-12
• Fit .....	B5-13
• Installation of the Ball Cage.....	B5-13
<b>Model No. ....</b>	<b>B5-14</b>
• Model Number Coding.....	B5-14
<b>Precautions on Use .....</b>	<b>B5-15</b>

## A Product Descriptions (Separate)

<b>LM Stroke Models ST, ST-B and STI..</b>	<b>A5-2</b>
• Structure and Features .....	A5-2
• Types and Features .....	A5-3
• Rated Load and Nominal Life .....	A5-4
• Table of Equivalent Factors .....	A5-7
• Accuracy Standards .....	A5-8
• Fit .....	A5-8
• ST Shaft .....	A5-9
• Installation of the ST Shaft .....	A5-9
<b>Dimensional Drawing, Dimensional Table</b>	
Models ST / ST-B .....	A5-10
Models ST...UU/ST...UUB.....	A5-14
<b>Miniature Stroke Model MST .....</b>	<b>A5-18</b>
• Structure and Features .....	A5-18
• Fit .....	A5-19
• Travel Distance of the Ball Cage .....	A5-19
<b>Dimensional Drawing, Dimensional Table</b>	
Model MST .....	A5-20
<b>Die-setting Ball Cage Models KS and BS..</b>	<b>A5-22</b>
• Structure and Features .....	A5-22
• Rated Load and Service Life.....	A5-22
• Fit .....	A5-23
• Installation of the Ball Cage.....	A5-23
<b>Dimensional Drawing, Dimensional Table</b>	
Models KS / BS .....	A5-24
<b>Model No. ....</b>	<b>A5-25</b>
• Model Number Coding.....	A5-25
<b>Precautions on Use .....</b>	<b>A5-26</b>

# ST

## LM Stroke Models ST, ST-B and STI

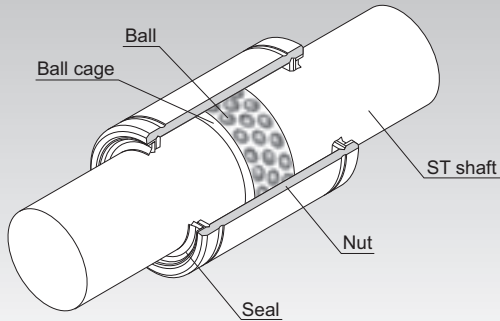

Fig.1 Structure of LM Stroke Model ST

## Structure and Features

Model ST has a ball cage and balls both incorporated into a precision-ground cylindrical nut as shown in Fig.1. The balls are arranged in zigzags so as to evenly receive a load. The ball cage is a drilled cage made of a light alloy with high rigidity, and is capable of high-speed motion. A thrust ring and a snap ring are installed on both sides of the inner surface of the nut to prevent the ball cage from overshooting.

This structure allows rotational motion, reciprocal motion and complex motion with a small friction coefficient. Model ST has a stroke length up to twice the range within which the ball cage can travel. Since high accuracy can be obtained at a low price, this model is used in a broad array of applications such as press die setting, ink roll unit of printing machine, workpiece chuck unit of punching press, press feeder, work head of electric discharge machine, wound roll corrector, spinning and weaving machine, distortion measuring equipment, spindle of optical measuring instrument, and photocopiers.

**[Minimal Friction Coefficient]**

The balls and the ball raceway are in point contact, which causes the smallest rolling loss, and the balls are individually retained in the ball cage. This allows the LM stroke to perform rolling motion at a minimal friction coefficient ( $\mu=0.0006$  to  $0.0012$ ).

**[Compact Design]**

Since it consists only of a thin nut and balls, the outer diameter of the bearing is minimized and a light, space-saving, compact design is achieved.

**[High Accuracy at a Low Price]**

A highly accurate slide unit can be produced at a low price.

---

## Types and Features

---

### Light Load Type Model ST

Model ST is a light load type that allows for a long stroke.

Shaft diameter:  $\phi 6$  to  $\phi 100$

In addition, a type attached with seal is available. Model ST-UU

Specification Table⇒ **A-5-10**

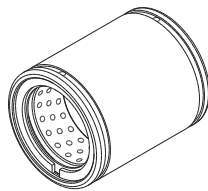

Model ST

### Medium Load Type Model ST-B

It has the same dimensions as model ST, but has a shorter stroke and achieves a rated load twice that of ST.

Shaft diameter:  $\phi 8$  to  $\phi 100$

In addition, a type attached with seal is available. Model ST-UUB

Specification Table⇒ **A-5-10**

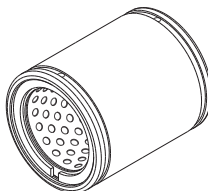

Model ST-B

### Inner Ring Type Model STI

If the LM shaft cannot be hard quenched, STI allows an inner ring to be incorporated. The inner ring is available build-to-order.

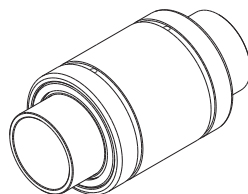

Model STI

---

## Rated Load and Nominal Life

---

### [Load Rating]

The basic load ratings for model ST are indicated in the respective specification tables.

### [Nominal Life]

The nominal life of model ST is obtained using the following equation.

$$L = \left( \frac{f_H \cdot f_T \cdot f_C}{f_W} \cdot \frac{C}{P_C} \right)^3$$

- L : Nominal life (rotating  $10^6$  times)  
(The total number of revolutions that 90% of a group of identical LM strokes independently operating under the same conditions can achieve without showing flaking)
- C : Basic dynamic load rating (N)
- $P_C$  : Calculated radial load (N)
- $f_H$  : Hardness factor (see Fig.2 on **B5-6**)
- $f_T$  : Temperature factor (see Fig.3 on **B5-6**)
- $f_C$  : Contact factor (see Table1 on **B5-7**)
- $f_W$  : Load factor (see Table2 on **B5-7**)

### ● When a Moment Load is Applied to a Single Nut

When a moment load is applied to a single nut, calculate the equivalent radial load from the moment.

$$P_u = K \cdot M$$

- $P_u$  : Equivalent radial load (N)  
(with moment load)
- K : Equivalent factor  
(see Table3 to Table4 on **A5-7**)
- M : Applied moment (N-mm)
- $P_u$  is assumed to be within the Basic Static Load Rating ( $C_0$ ).

### ● When a Moment Load and a Radial Load are Simultaneously Applied

When a moment and a radial load are applied simultaneously, calculate the service life based on the sum of the radial load and the equivalent radial load.



### [Calculating the Service Life Time]

When the nominal life (L) has been obtained, if the number of revolutions per minute and the number of reciprocations per minute are constant, the service life time is obtained using the following equation.

#### ● For Rotating Motion or Complex Motion

$$L_h = \frac{10^6 \times L}{60 \sqrt{(dm \cdot n)^2 + (10 \times \alpha \cdot \ell_s \cdot n_1)^2} / dm}$$

#### ● For Reciprocating Motion

$$L_h = \frac{10^6 \times L}{60 \times 10 \times \alpha \cdot \ell_s \cdot n_1 / (\pi \cdot dm)}$$

$L_h$	: Service life time	(h)
$n$	: Revolutions per minute	( $\text{min}^{-1}$ )
$n_1$	: Number of reciprocations per minute	( $\text{min}^{-1}$ )
$\ell_s$	: Stroke length	(mm)
$dm$	: Pitch circle diameter ( $dm \doteq 1.15 \times dr$ )	(mm)
$dr$	: Ball inscribed bore diameter	(mm)
$\alpha$	: Factor for cage material ( $\alpha=0.7$ )	

### [Tolerance Value in Rotation and Reciprocating Speed]

The permissible speed limit of model ST is obtained using the following equation.

$$DN \geq dm \cdot n + 10 \times l_s \cdot n_1$$

For the DN value above, the following value applies as a standard value.

For oil lubrication  $DN=600000$

For grease lubrication  $DN=300000$

However, the following points must be taken into account.

$n \leq 5000$

$l_s \cdot n_1 \leq 50000$

#### ● $f_H$ : Hardness Factor

To maximize the load capacity of model ST, the hardness of the raceways needs to be between 58 to 64 HRC.

If the hardness is lower than this range, the basic dynamic load rating and the basic static load rating decrease. Therefore, it is necessary to multiply each rating by the respective hardness factor ( $f_H$ ).

Normally,  $f_H=1.0$  since model ST has sufficient hardness.

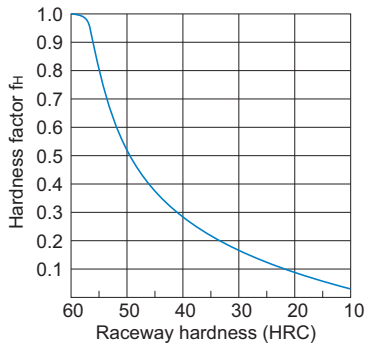

Fig.2 Hardness Factor ( $f_H$ )

#### ● $f_T$ : Temperature Factor

If the temperature of the environment surrounding the operating model ST exceeds 100°C, take into account the adverse effect of the high temperature and multiply the basic load ratings by the temperature factor indicated in Fig.3.

Note) If the environment temperature exceeds 80°C, contact THK.

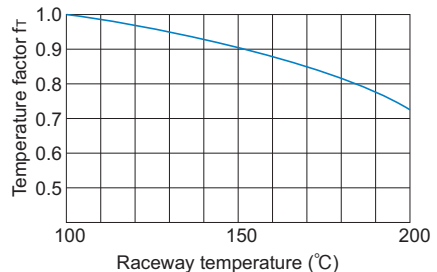

Fig.3 Temperature Factor ( $f_T$ )

### ● $f_c$ : Contact Factor

When multiple nuts of model ST are used in close contact with each other, their linear motion is affected by moments and mounting accuracy, making it difficult to achieve uniform load distribution. In such applications, multiply the basic load rating (C) and ( $C_0$ ) by the corresponding contact factor in Table1.

Note) If uneven load distribution is expected in a large machine, take into account the respective contact factor indicated in table 1.

Table1 Contact Factor ( $f_c$ )

Number of nuts in close contact with each other	Contact factor $f_c$
2	0.81
3	0.72
4	0.66
5	0.61
Normal use	1

### ● $f_w$ : Load Factor

In general, reciprocating machines tend to involve vibrations or impact during operation. It is extremely difficult to accurately determine vibrations generated during high-speed operation and impact during frequent start and stop. Therefore, when speed and vibrations have a significant influence, divide the basic dynamic load rating (C or  $C_0$ ), by the corresponding load factor in Table2 of empirically obtained data.

Table2 Load Factor ( $f_w$ )

Vibrations/ impact	Speed (V)	$f_w$
Faint	Very low $V \leq 0.25\text{m/s}$	1 to 1.2
Weak	Slow $0.25 < V \leq 1\text{m/s}$	1.2 to 1.5
Medium	Medium $1 < V \leq 2\text{m/s}$	1.5 to 2
Strong	High $V > 2\text{m/s}$	2 to 3.5

## Accuracy Standards

The tolerance value in inscribed bore diameter (dr), nut outer diameter (D) and nut length (L) is indicated in the corresponding specification table.

The end of the nut may be deformed due to tension of the snap ring. Therefore, when measuring the nut outer diameter, it is necessary to calculate the measurement range using the following equation, and obtain the average diameter value within the range.

The tolerance value in the nut outer diameter is equal to the calculated average value of the maximum diameter and the minimum diameter obtained through two-point measurement of the outer diameter.

$$W = 4 + \frac{L}{8}$$

W : Length out of the measurement range (mm)  
 L : Nut length (mm)

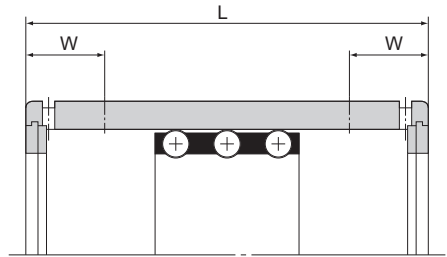

Fig.4 Measurement Range of the Nut

## Fit

In theory, the ball cage of model ST moves in the same direction as the ST shaft by 1/2 of the shaft (or nut). However, to minimize the travel distance error caused by uneven load distribution or vibrations, it is necessary to reduce the clearance. If high accuracy is required or if the LM Stroke is used on a vertical shaft, we recommend setting the radial clearance between 0 and 10 μm.

Item	Normal conditions	Vertical shaft or high accuracy
ST shaft	k5, m5	n5, p5
Housing	H6, H7	J6, J7

---

## ST Shaft

---

With the ST shaft, used in model ST, balls roll directly on the shaft surface. Therefore, it is necessary to pay much attention to the hardness, surface roughness and dimensional accuracy when manufacturing it.

Since the hardness of the ST shaft has especially large impact on the service life, use much care in selecting a material and heat treatment method.

THK also manufactures high-quality ST shafts. Contact us for details.

### [Material]

Generally, the following materials are used as suitable for surface hardening through induction-hardening.

- SUJ2 (JIS G 4805: high-carbon chromium bearing steel)
- SK3 to 6 (JIS G 4401: carbon tool steel)
- S55C (JIS G 4051: carbon steel for machine structural use)

### [Hardness]

We recommend surface hardness of 58 HRC ( $\approx$ 653 HV) or higher. The depth of the hardened layer is determined by the shaft diameter; we recommend approximately 2 mm for general use.

The ST shaft can have a hardened inner ring attached on the shaft raceway.

### [Surface Roughness]

To achieve smooth motion, the surface is normally finished to 0.40a or less. If higher wear resistance is required, finish the surface to 0.20a or less.

---

## Installation of the ST Shaft

---

To install the ST shaft, drive it in to the designated depth. If the clearance is negative, a large driving force is required. However, do not forcibly hammer the shaft. Instead, apply a lubricant on the ST shaft first, and then gradually drive it in with a slight back action.

# MST

## Miniature Stroke Model MST

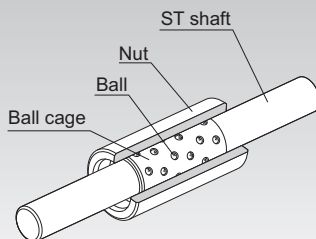

Fig.1 Structure of Miniature Stroke Model MST

## Structure and Features

Model MST consists of an ST shaft, ball cage and nut. These components can freely be combined according to the application. The sectional shape is small, the clearance is minimal and the motion is extremely light and smooth. Accordingly, model MST can be used in a variety of small, precision measuring equipment such as optic measuring instrument's spindle, pen plotter, OA equipment, computer terminals, automatic scale, digital length measuring machine and solenoid valve.

### [Highly Accurate Bearing]

Precision steel balls (sphericity in mutual difference: 0.0003 mm) compliant with JIS B 1501 are incorporated in a copper alloy ball cage to ensure high accuracy. The ball cage serves to prevent the balls from falling off with a unique ball-retaining design.

### [Highly Durable Bearing]

The nut of the ST shaft uses a selected material, and is heat-treated and ground. In addition, the raceways are finished with ultra fine finish. The rows of balls are densely arranged in the ball cage, and the balls are placed so that the ball raceways do not overlap with each other. It enables this model to be used over a long period without wear and to demonstrate high durability.

**[Compact Bearing]**

Use of a combination of balls with a 1 mm diameter and a thin nut allows a small sectional shape and space-saving design.

**[Bearing with Extremely Low Frictional Resistance]**

Since the balls are in point-contact with the raceways, rolling loss is minimal and rolling motion with low-friction is achieved.

---

**Fit**

---

The inner surface of the housing must be finished to H6 to H7, and secured with an adhesive after the nut is inserted.

When press fitting is required, mounting the nut to the hole will reduce the inner diameter. Therefore, be sure to check the inner diameter after press fitting the nut and adjust the shaft diameter so that a correct preload is achieved. Also make sure that the preload must not exceed  $-2\mu\text{m}$ .

---

**Travel Distance of the Ball Cage**

---

The ball cage can travel up to 1/2 of the stroke length ( $\ell_s$ ) of the nut or the ST shaft in the same direction.

# KS/BS

## Die-setting Ball Cage Models KS and BS

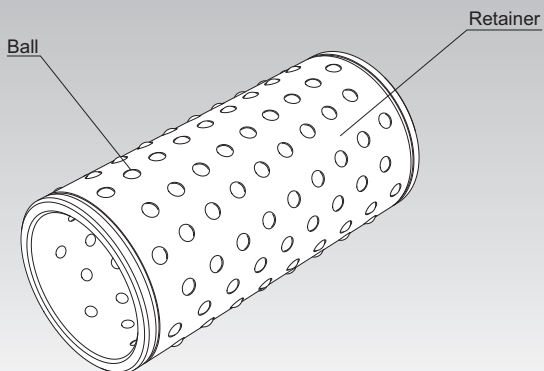

Fig.1 Structure of Die-setting Ball Cage Model KS

### Structure and Features

With models KS and BS, a large number of precision steel balls (sphericity in mutual difference: 0.0005 mm) compliant with JIS B 1501 are incorporated in a lightweight, highly rigid ball cage. The balls are arranged along the circumference of the ball cage in spirals so that the ball raceways do not overlap with each other. It enables these models to be used over a long period without wear and to demonstrate high durability.

In addition, the ball pockets, which hold the balls, are finished with precision and continuously caulked with a unique process, enabling them to prevent the balls from falling. It allows the system to travel smoothly even if the ball cage is longer than the housing.

These ball cages are used in precision press die set, spinning and weaving machine, precision measuring instrument, automatic recorder, medical equipment and various machine tools.

### Rated Load and Service Life

The rated loads of models KS and BS are indicated in the respective specification tables. Their service lives are obtained using the service life equation for LM Stroke model ST on [B5-4](#).



## Fit

When using the Die-setting Ball Cage in the guide unit of the guide post of a precision press die set, normally select a negative clearance in order to increase the accuracy and the ball cage rigidity. Table1 shows typical fitting between the hole and the shaft. Select a combination of a hole and a shaft so that the clearance does not exceed the tolerance value of the radial clearance indicated in the specification table.

Table1 Fitting between Holes and Shaft

Tolerance in hole dimensions: D	K5
Dimensional tolerance of the shaft: d	h5

## Installation of the Ball Cage

Fig.2 shows examples of mounting the Die-setting Ball Cage.

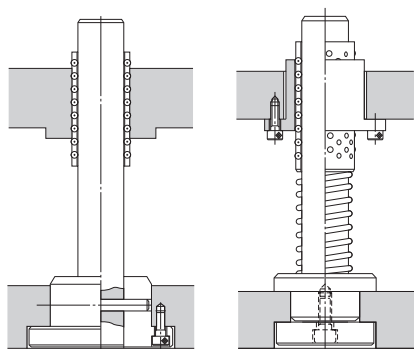

Fig.2 Example of Installation

## Model Number Coding

Model number configurations differ depending on the model features. Refer to the corresponding sample model number configuration.

### [LM Stroke]

- Models ST, ST-B, ST...UU and ST...UUB

**ST20UUB**

Model No.

### [Miniature Stroke]

- Models M, S, T and MST

- Ball Cage only
- Nut only
- ST shaft only

**M4610**

Model No.

**S6820**

Model No.

**T460**

Model No.

- Ball cage, nut and ST shaft combinations

**MST 4-10 20 60 M**

ST shaft outer diameter dimension (mm)	Ball cage length (mm) (A)	Nut length (mm) (B)	ST shaft length (mm) (C)	Using stainless steel
--	---------------------------	---------------------	--------------------------	-----------------------

Combined model number (ball cage): M4610 (nut): S6820 (ST shaft): T460 Combination of these components

Note) The model numbers of ball cage, nut and ST shaft are indicated in the corresponding specification table.

### [Die-setting Ball Cage]

- Models KS and BS

**KS3880**

Model No.

## [Handling]

- (1) Do not disassemble the parts. This will result in loss of functionality.
- (2) Take care not to drop or strike the LM Stroke. Doing so may cause injury or damage. Giving an impact to it could also cause damage to its function even if the product looks intact.
- (3) When handling the product, wear protective gloves, safety shoes, etc., as necessary to ensure safety.

## [Precautions on Use]

- (1) With the model ST LM Stroke, intrusion of foreign matter can cause abnormal wear and reduce service life. If there is a risk of foreign material intruding, use a seal or another protective option suited to the usage conditions and surrounding environment. A highly abrasion-resistant synthetic rubber seal (model ST...UU) and dust-proof felt seal with low seal resistance (model ST...DD) are available for the model ST.
- (2) If foreign material such as cutting chips adheres to the product, replenish the lubricant after cleaning the product.
- (3) Do not use the product at temperature of 80°C or higher. Exposure to higher temperatures may cause the resin/rubber parts to deform/be damaged.
- (4) If the product is used in an environment where cutting chips, coolant, corrosive solvents, water, etc., may enter the product, use bellows, covers, etc., to prevent them from entering the product.
- (5) Micro-strokes tend to obstruct oil film to form on the raceway in contact with the rolling element, and may lead to fretting corrosion. Take consideration using grease offering excellent fretting prevention. It is also recommended that a stroke movement corresponding to the length of the ball cage be made on a regular basis to make sure oil film is formed between the raceway and rolling element.
- (6) Do not use undue force when fitting parts (pin, key, etc.) to the product. This may generate pressure marks on the raceway, leading to loss of functionality.
- (7) Insert the shaft straight through the opening. Inserting the shaft at an angle can introduce foreign matter, damage internal components, or cause balls to fall out.
- (8) Using this product with any balls removed may result in premature damage.
- (9) Please contact THK if any balls fall out; do not use the product if any balls are missing.
- (10) If an attached component is insufficiently rigid or mounted incorrectly, the bearing load will be concentrated at one location and performance will decline significantly. Make sure the housing and base are sufficiently rigid, the anchoring bolts are strong enough, and the component is mounted correctly.

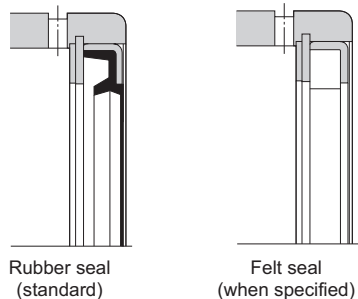

Fig.1 Seals used with the LM Stroke

### [Lubrication]

- (1) Thoroughly wipe off anti-rust oil and feed lubricant before using the product.
- (2) Do not mix different lubricants. Mixing greases using the same type of thickening agent may still cause adverse interaction between the two greases if they use different additives, etc.
- (3) When using the product in locations exposed to constant vibrations or in special environments such as clean rooms, vacuum and low/high temperature, use the grease appropriate for the specification/environment.
- (4) When lubricating the product, apply grease directly on the raceway and stroke the product several times to let the grease spread inside.
- (5) The consistency of grease changes according to the temperature. Take note that the slide resistance of the LM Stroke also changes as the consistency of grease changes.
- (6) After lubrication, the slide resistance of the LM Stroke may increase due to the agitation resistance of grease. Be sure to perform a break-in to let the grease spread fully, before operating the machine.
- (7) Excess grease may scatter immediately after lubrication, so wipe off scattered grease as necessary.
- (8) The properties of grease deteriorate and its lubrication performance drops over time, so grease must be checked and added properly according to the use frequency of the machine.
- (9) The greasing interval varies depending on the use condition and service environment. Set the final lubrication interval/amount based on the actual machine.
- (10) The model ST LM Stroke can be lubricated with either oil or grease. Select the appropriate option in accordance with the DN value. THK recommends lithium grease no. 2.

### [Storage]

When storing the LM Stroke, enclose it in a package designated by THK and store it in a room while avoiding high temperature, low temperature and high humidity.

### [Disposal]

Dispose of the product properly as industrial waste.