

BEARINGS FOR THE
STEEL INDUSTRY



As one of the world's leading manufacturers of rolling bearings, linear technology components and steering systems, we can be found on almost every continent – with production facilities, sales offices and technology centres - because our customers appreciate short decision-making channels, prompt deliveries and local service.



The NSK company

NSK commenced operations as the first Japanese manufacturer of rolling bearings back in 1916. Ever since, we have been continuously expanding and improving not only our product portfolio but also our range of services for various industrial sectors. In this context, we develop technologies in the fields of rolling bearings, linear systems, components for the automotive industry and mechatronic systems. Our research and production facilities in Europe, Americas and Asia are linked together in a global technology

network. Here we concentrate not only on the development of new technologies, but also on the continuous optimisation of quality – at every process stage.

Among other things, our research activities include product design, simulation applications using a variety of analytical systems and the development of different steels and lubricants for rolling bearings.

Partnership based on trust – and trust based on quality

Total Quality by NSK: The synergies of our global network of NSK Technology Centres. Just one example of how we meet our requirements for high quality.

NSK is one of the leading companies with a long tradition in patent applications for machine parts. In our worldwide research centres, we not only concentrate on the development of new technologies, but also on the continual

improvement of quality based on the integrated technology platform of tribology, material technology, analysis and mechatronics.

More about NSK at www.nskeurope.com or call us on + 441636 605123



Robust, wear-resistant and durable – NSK’s rolling bearings for the iron and steel industry

It’s a tough life in the iron and steel industry: variations in temperature, high levels of contamination, belt speeds of more than 2000 metres a minute, rocking motions and impacts. NSK rolling bearings take all of this in their stride; from the preparation of the raw material, through the smelting process, right up to the final rolled product.

We offer bearings that have been specially developed for all the relevant conditions encountered throughout the entire process. That’s why, for example, we have developed sealed spherical roller bearings for continuous casting plants that prevent the ingress of contamination and offer optimal service life. Our taper roller bearings and cylindrical roller bearings with self aligning outer ring are also perfectly suited for continuous casting plants.

Then there are our taper roller bearings which are available in various special materials for rolling mills such as Water-TF and Super-TF together with our Sealed-Clean technology. Beyond that, we offer various bearings for sinter machines, LD converters, chain conveyors, levellers and many more.

Reducing downtime through increased reliability

The variants are many, but all our products have one thing in common: they are reliable, wear-resistant and durable - thereby ensuring profitable production.

Innovation made by NSK – Sealed-Clean

In 1980, NSK was the first company in the world to bring the sealed four row tapered roller bearing (Sealed Clean) on to the market. Since then, we have continually improved the Sealed-Clean bearing. In this way, we have been able to measurably increase its load-carrying capacity through newly-developed internal construction and a new sealing system. Even grease consumption has been drastically reduced; which not only leads to lower costs but also makes it more environmentally friendly. Sealed-Clean bearings can be supplied in case-hardened and through-hardened steel. NSK’s various steel specifications are particularly wear and shock resistant due to our special heat and surface treatment technology.

Sealed-Clean™ bearings for extreme conditions



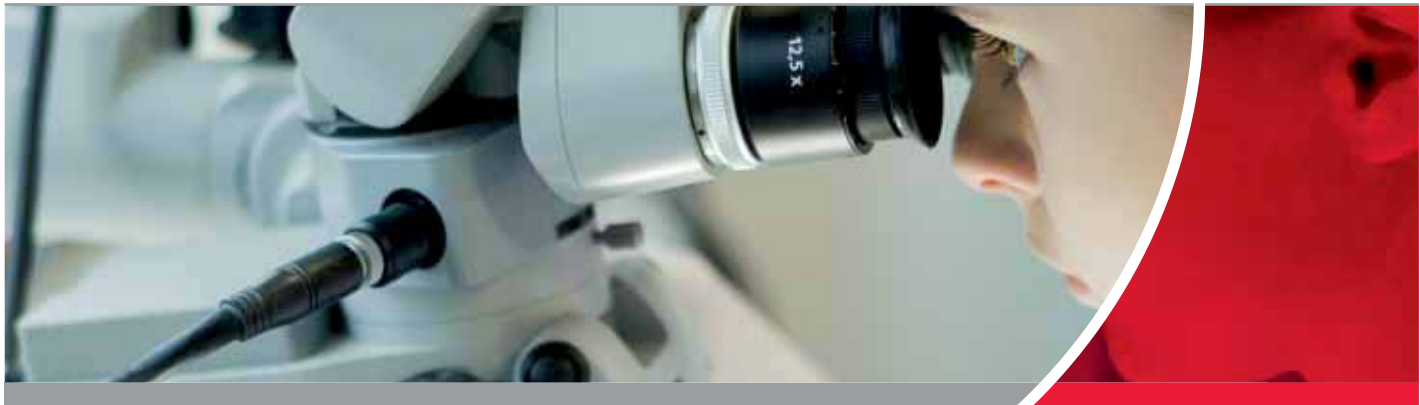

**The best combination for new developments:
research and practical experience**

NSK rolling bearings for the iron and steel industry are the result of intense research and development, as well as a close working relationship with our clients. As a result of the demands of practical experience, we conduct a continuous improvement programme

for our products, with as much regard to construction as materials and lubrication. In order to guarantee the highest standards of quality and reliability under the harshest of conditions, all NSK products undergo the most stringent testing on our test rigs

Development of rolling bearings for the iron and steel industry

Design and materials

Development of new types of construction and the use of innovative materials for longer operational life under harsh operating conditions.

Simulation

Simulation techniques in various operational environments

Analysis and Diagnosis

- › Bearing analysis techniques
- › Fatigue damage analysis
- › Diagnostic techniques

Test rig for the appraisal of performance and durability under realistic operating conditions



Test rig for bearings used in guide rolls of continuous casting machines



Test rig for bearings used in backup rolls of rolling mills



Test rig for bearings used in work rolls of rolling mills

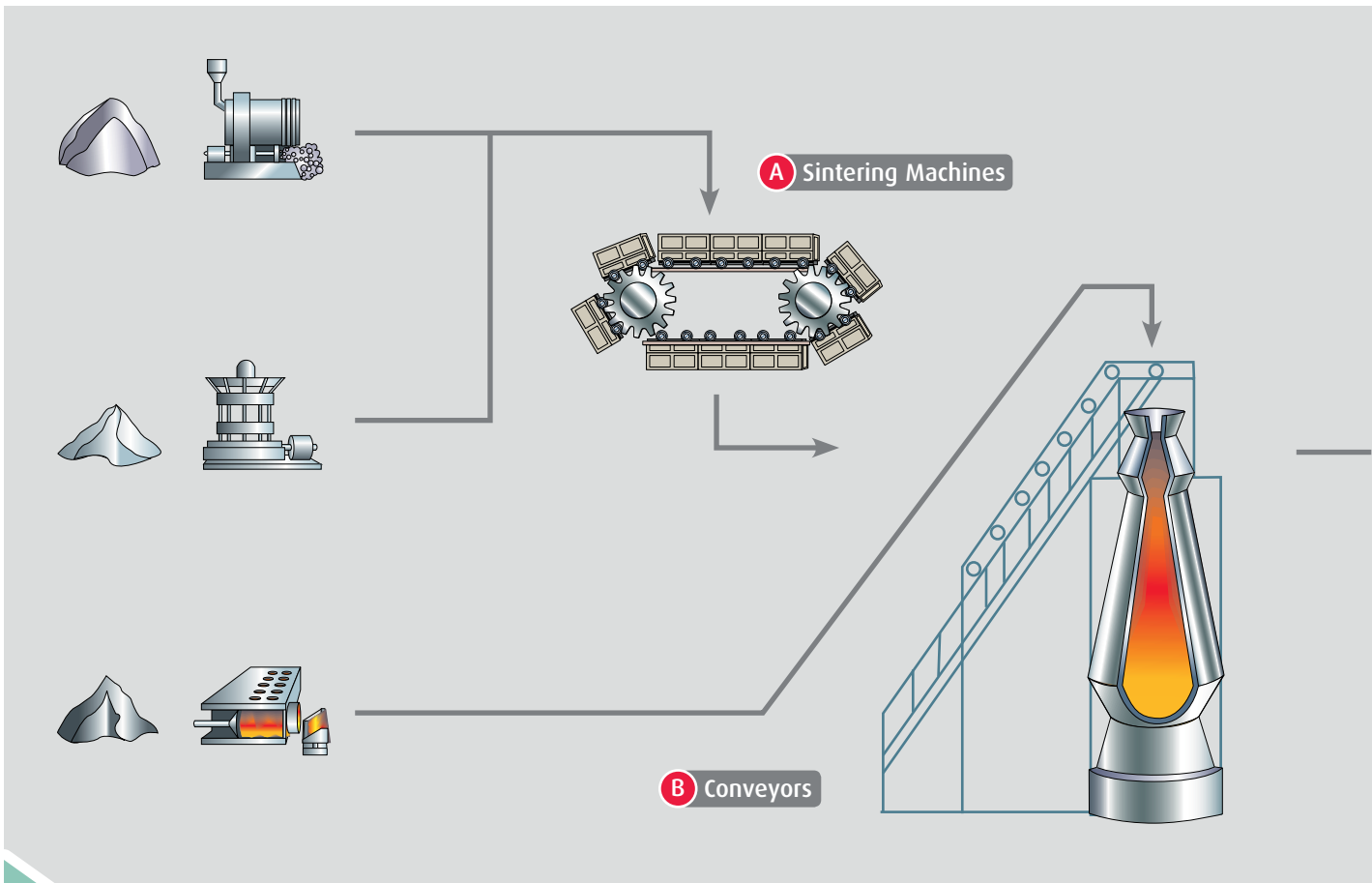

CRUDE (up from page 10)

NSK products for the entire iron and steel industry process

Rolling bearings for iron and steel mills have to withstand varied and extreme operating conditions, amongst which high temperatures, high or low rotational speeds, as well as environments that are contaminated with water or dirt. We offer a whole range of products for all mill processes; products that deliver reliable and continuous operation under all conditions.

A Sintering Machines



Sealed-Clean™ Bearings for Sintering Machine Pallets

B Conveyors



HPS™ Spherical Roller Bearings



Plummer Blocks

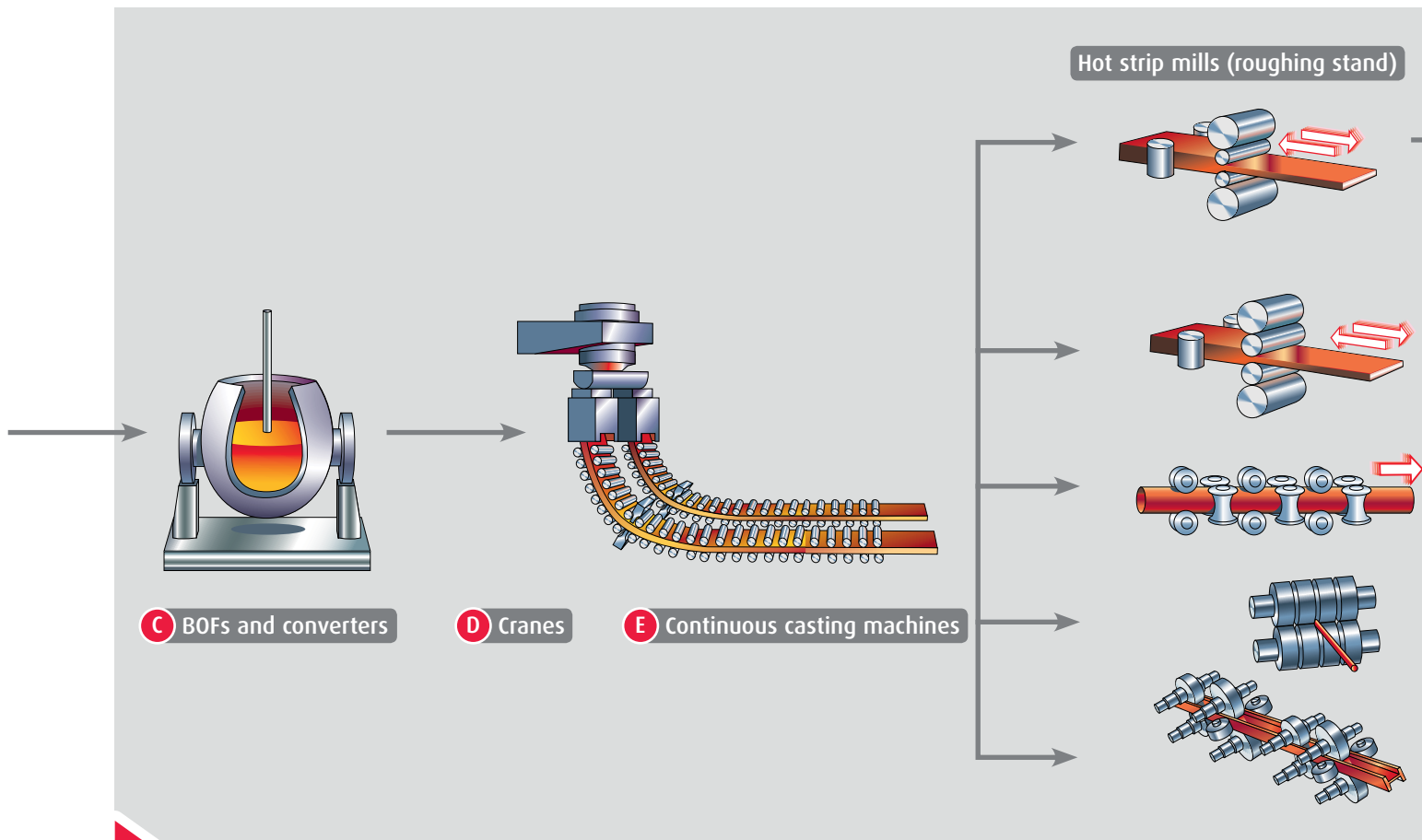

HOT (up from page 12)

C BOFs and converters



Ultra-Large Split Bearings for BOFs and Converter Trunnions

D Cranes



DIN-Standard Full-Complement Cylindrical Roller Bearings for Crane Sheaves

E Continuous casting machines



Tapered Roller Bearings with Aligning Rings



Cylindrical Roller Bearings with Aligning Rings



Split Roller Bearing Units for Segmented Rolls



SWR™ Bearings

F Plate mills



Four-Row Cylindrical Roller Bearings for Backup Rolls (with stud-type cages for super heavy loads)

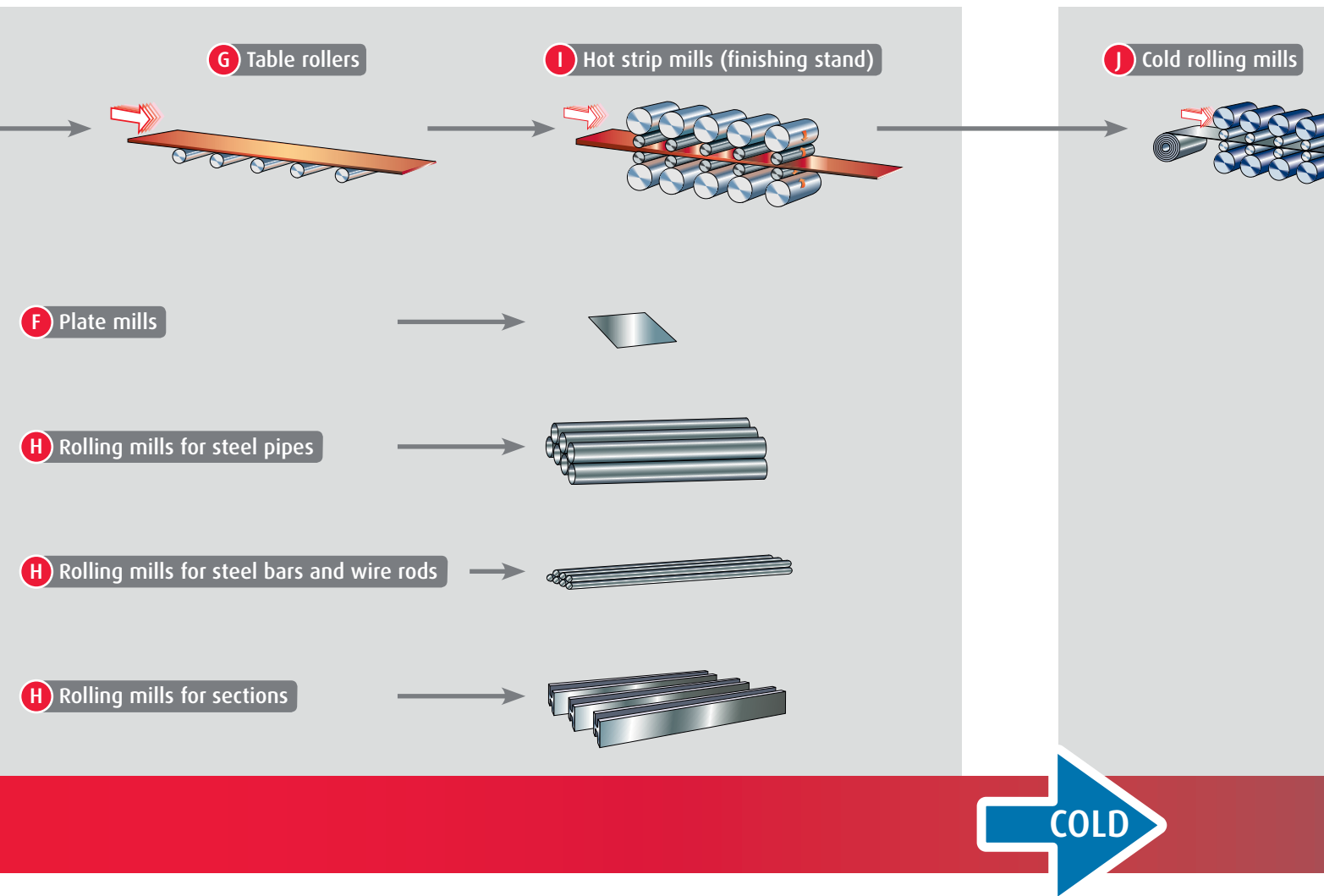

G Table rollers



Molded-Oil™ Bearings



Sealed-Clean™ Spherical Roller Bearings



Plummer Blocks



Cylindrical Roller Bearings EW + EM Series

H Rolling mills for steel pipes, steel bars, wire rods and sections



Four-Row Cylindrical Roller Bearings and Four-Row Tapered Roller Bearings for Horizontal Rolls



Four-Row Tapered Roller Bearings for Vertical Rolls

I Hot strip mills (finishing stand)



Four-Row Cylindrical Roller Bearings and Four-Row Tapered Roller Bearings for Roll Necks



Tapered Roller Bearings for Axial Loads

L Skin pass mills

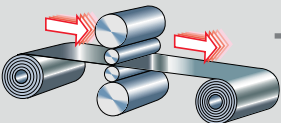

N Tension levellers

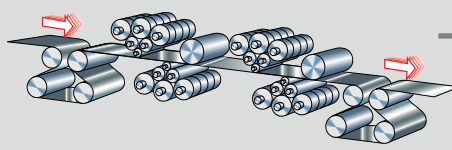

K Multi-roll rolling cluster mills

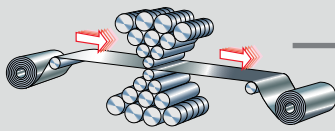

M Chain conveyors

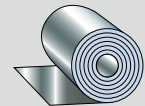
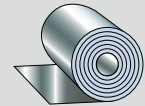
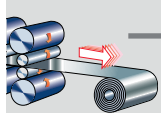
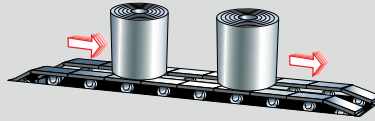

(up from page 22)

J Cold rolling mills



Four-Row Cylindrical Roller Bearings and Four-Row Tapered Roller Bearings for Roll Necks

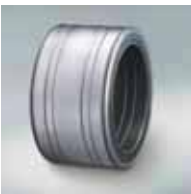

WTF® Bearings



Extra-Capacity Sealed-Clean™ Four-Row Tapered Roller Bearings



Double-Row Tapered Roller Bearings for Axial Loads

K Multi-roll rolling cluster mills



Backing Bearings for Backup Rolls

L Skin pass mills



Extra-Capacity Sealed-Clean™ Four-Row Tapered Roller Bearings



Four-Row Cylindrical Roller Bearings for Backup Rolls

M Chain conveyors



S-Type Sealed-Clean™ Bearings for Chain Conveyors

N Tension levellers



Bearing Units for Tension Levellers

Bearings for Sintering Equipment

Sealed-Clean Bearings for Pallet Wheels
 Sealed-Clean Bearings for Inboard Rollers

1. Operating conditions

- › High temperature
- › Heavy loads
- › Low speed
- › Scale (sintered particles)

Sintering equipment

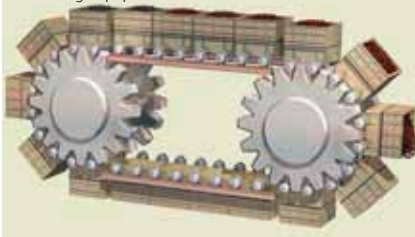

Conventional Structure

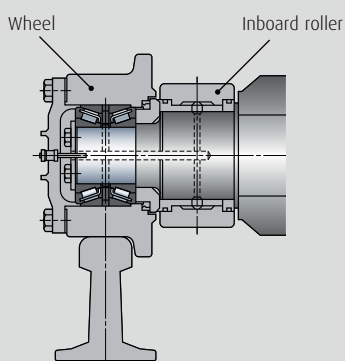

2. Problems

Problem 1

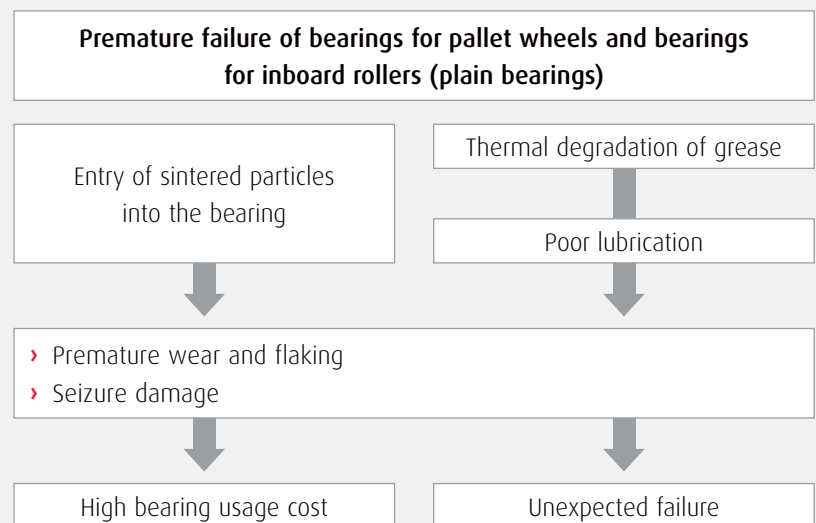

Problem 2

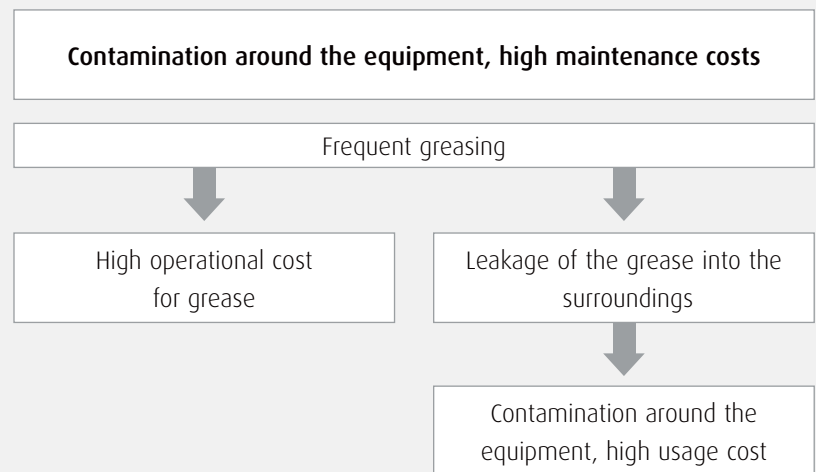



3. Countermeasures

Design measures

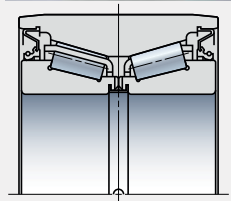

Sealed-Clean Bearings for Pallet Wheels – AR Series*

- › Optimum crowning of the roller raceway surface enabling resistance to unbalanced load of wheels
- › High sealing performance (featuring a special contact seal)
- › Packing of grease with excellent heat and pressure resistance
- › Easier handling (one-piece design with fastening ring adopted for the inner ring)

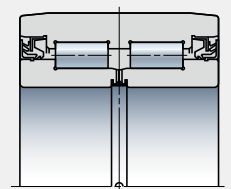

Sealed-Clean Bearings for Inboard Rollers – 2J Series*

- › Higher load capacity (by outer ring thickness design with high strength and full-complement roller type)
- › Improvement of axial load capacity
- › High sealing performance (featuring a special contact seal)
- › Packing of grease with excellent heat and pressure resistance
- › Easier handling (one-piece design with fastening ring adopted for the inner ring)

4. Benefits

- › Stable machinery operation through higher reliability and longer operating life
- › Cleaner areas adjacent to equipment
- › Reduced maintenance costs

Durability Performance of Bearings in Field Test

- › Conventional structure = 1
- › Newly developed structure = \varnothing 2,5, max. 3

Previous	1
New	2.5 on average < 3

Estimated effect of maintenance cost reduction

Previous	Maintenance cost
New	Maintenance cost < Cost saving

The maintenance cost includes the replacement costs for bearings, seals and grease and the operational costs associated with the bearing replacement and greasing.

If the bearing life extends 2.5 times on average as a result of using the newly developed structure for bearings for pallet wheels/inboard rollers for pallet dollies, the total maintenance cost reduction effect is estimated to be 25% to 35%.

Newly developed structure

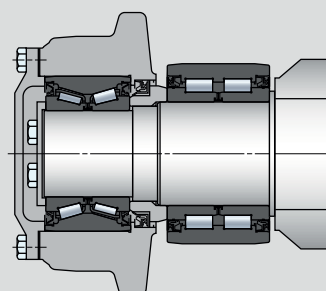

* Bearing tables see page 30

Bearings for BOFs and Converters

Ultra-Large Split Bearings for BOFs and Converter Trunnions

1. Operating conditions

- › High temperature
- › Heavy loads
- › Ultra-low speed and Oscillating

BOFs and converters



Conventional structure

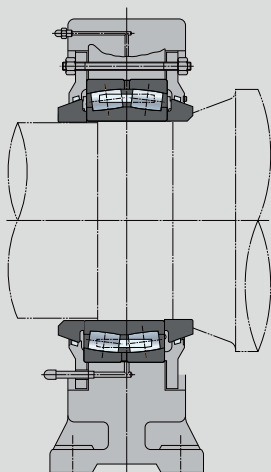

2. Typical Problems

Inboard bearings cannot be replaced without removing the bull gear

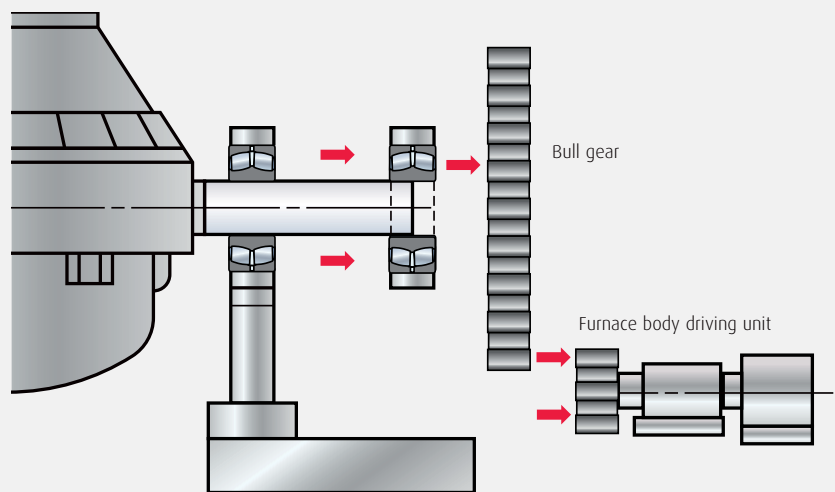

Bearing replacement work is time-consuming, requiring high maintenance costs

In addition, sudden bearing replacement due to an unexpected failure causes large production loss in the subsequent processes



3. Countermeasures



Ultra-Large Split Bearings for BOFs and Converter Trunnions*

- › A split design of ultra-large spherical roller bearings:
 - (1) outer ring
 - (2) inner ring
 - (3) roller and cage assembly and
 - (4) fastening ring
- › Seal sliding surface integrated by a fastening ring

Design measures

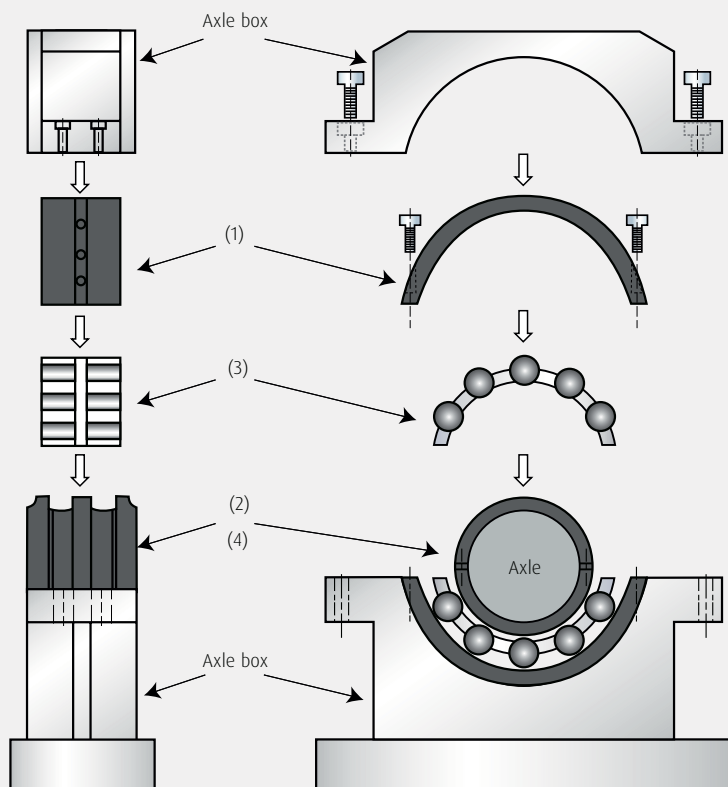

4. Benefits

- › Bearings can be replaced without removing the bull gear, thus reducing maintenance costs
- › Reduction of maintenance costs by shortening length of time for bearing replacement work
- › Reduction of production loss, which would affect subsequent processes

Comparison of time required for bearing replacement work in field test

Previous	1	
New	0.65	0.35

The bearing replacement period represents the actual result for bearings with bore diameter of 1200 mm to 1400 mm. In the case above, the bearing with the newly developed structure reduced the time needed for bearing replacement work by approximately 35%, and thereby significantly reduced maintenance cost.

Newly developed structure

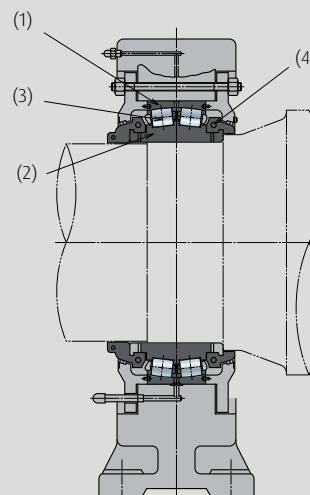

* Bearing tables see page31

Bearings for Continuous Casting Machines

Bearings for Guide Rolls

1. Operating conditions

- › Heat
- › Heavy loads
- › Water vapor (Water)
- › Ultra-low speed
- › Scale
- › Deflection of a roll

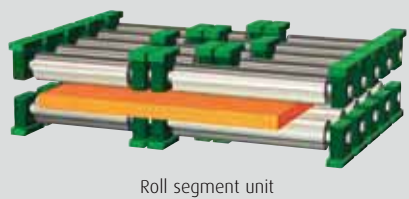
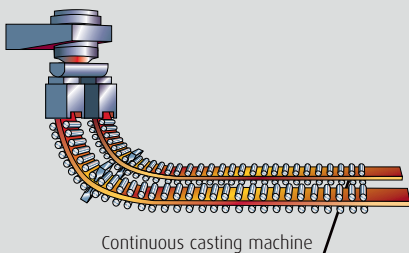

Conventional structure

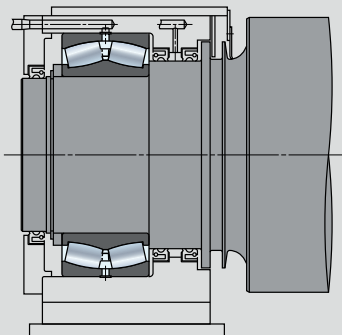

2. Typical problems

Differential sliding specific to spherical roller bearings



- › Uneven wear



Outer ring raceway surface



- › Flaking
- › Crack



Outer ring raceway surface



- › Expansion of roll gaps (failure of rolls)
- › Defective-quality products
- › Unexpected production line failure
- › High bearing usage cost



3. Countermeasures

Material measures



SWR™ Bearings (Spherical Roller Bearings) – SWR Series*

- › Improved wear resistance – three times compared to AISI 52100 bearing steel
- › Improved flaking life property – five times compared to AISI 52100 bearing steel
- › Improved toughness of material core (prevention of crack damage) – five times compared to AISI 52100 bearing steel

Design measures



Cylindrical Roller Bearings with Aligning Rings (for free end) – RUB Series*

- › Prevention of wear due to no differential sliding of spherical roller bearing and additional function of self-aligning (see page 18 for further explanation)
- › Smooth relief of roll expansion
- › Type: Easy handling cage type
Full-complement type with higher load capacity



Tapered Roller Bearings with Aligning Rings (for fixed end) – AR Series*

- › Prevention of wear due to no differential sliding of spherical roller bearing and additional function of self-aligning (see page 18 for further explanation)
- › High thrust load capacity



Split Cylindrical Roller Bearings (for segmented rolls) – RNPH/PCR Series*

- › Prevention of wear due to no differential sliding of spherical roller bearing. (see page 18 for further explanation)
- › Full-complement, higher load capacity design
- › Multi-functional seal and high rigidity plummer block unit

4. Benefits

- › Improved bearing durability prevents unexpected accidents
- › Roll segment is replaced less frequently, thus reducing maintenance costs

Newly developed structure

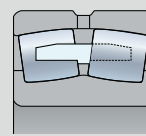

SWR

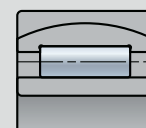

RUB

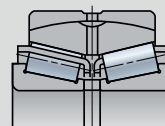

AR

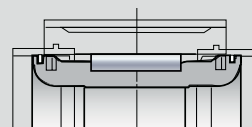

RCPH/PHR

Recommended bearing arrangements see next page

* Bearing tables see page 32-33 (SWR Series), page 34 (RUB Series), page 35 (AR Series), page 36-37 (RNPH/PCR)

Recommended Bearing Arrangements

NSK has prepared the following arrangements for bearings used in guide rolls of continuous casting machines with recently developed SWR™ Bearings and tapered roller bearings with aligning rings additionally.

Bearing arrangement for single rolls and split rolls

Case 1

Spherical roller bearings currently used can be replaced with SWR™ Bearings without modifying the axle boxes, thus easily enhancing performance:

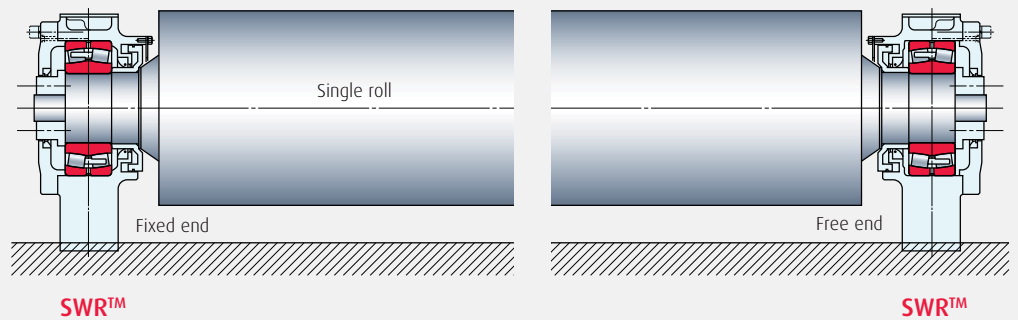

Case 2

Optimal bearing arrangement to relieve roll expansion:

The structure in the axle box needs to be partially modified in case of changing the free-end bearing from a spherical roller bearing to RUB.

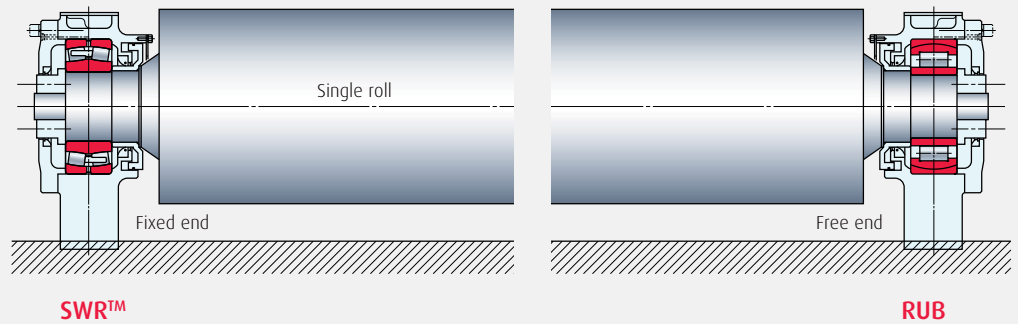

Case 3

Bearing arrangement to prevent roll expansion and roll thrust load:

The structure in the axle box needs to be partially modified in case of changing the fixed- and free-end bearings from spherical roller bearings to AR and RUB.

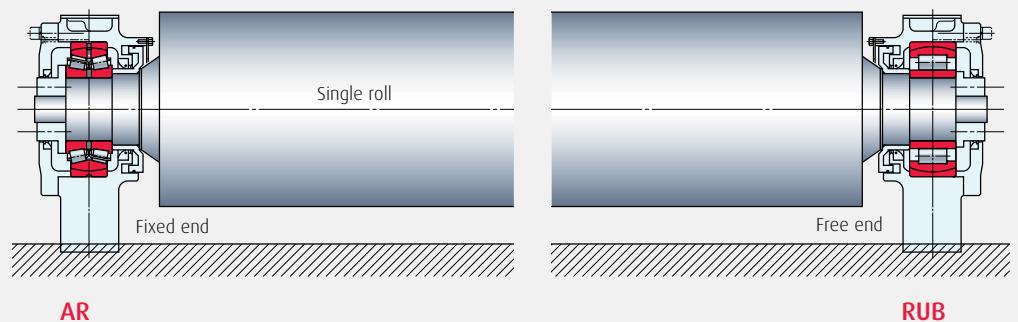

Bearing arrangement for segmented drive rolls

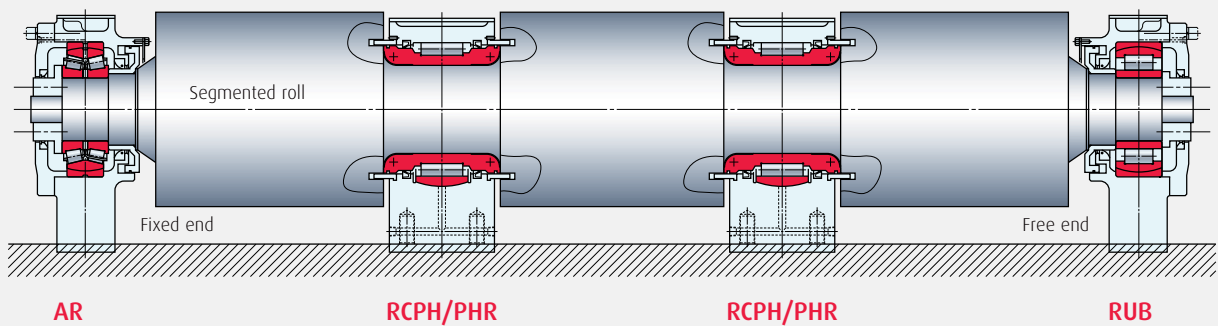
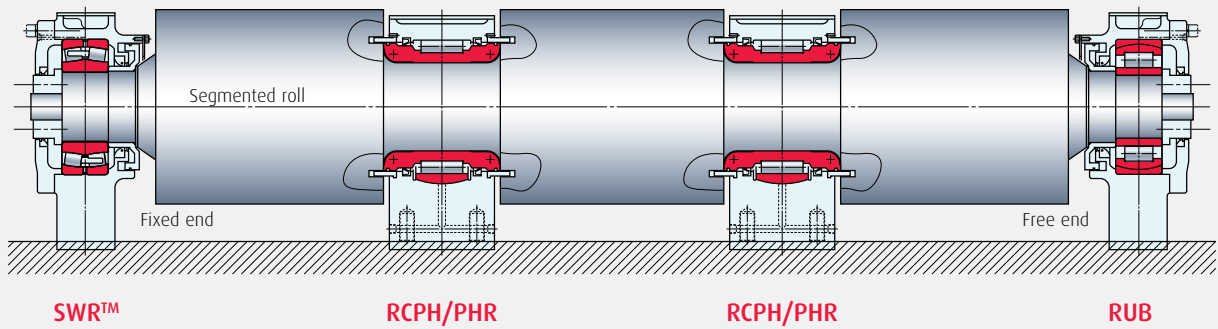
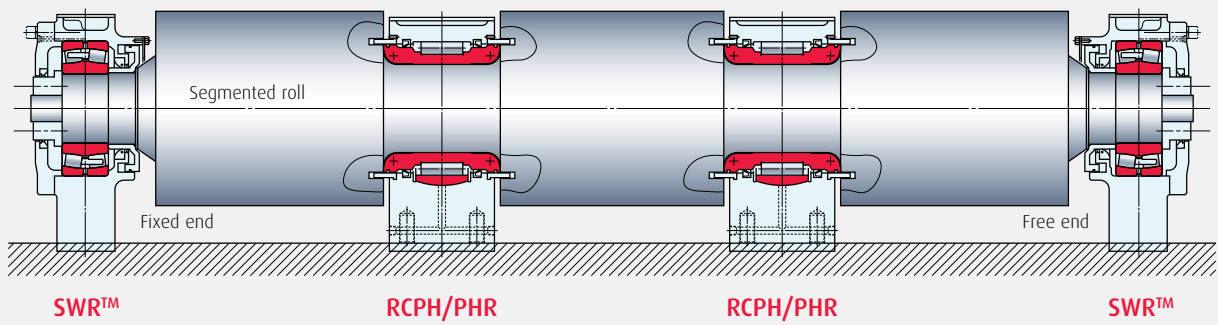



Identification of the failure mechanism

Failure mechanism of spherical roller bearings for continuous casting machines

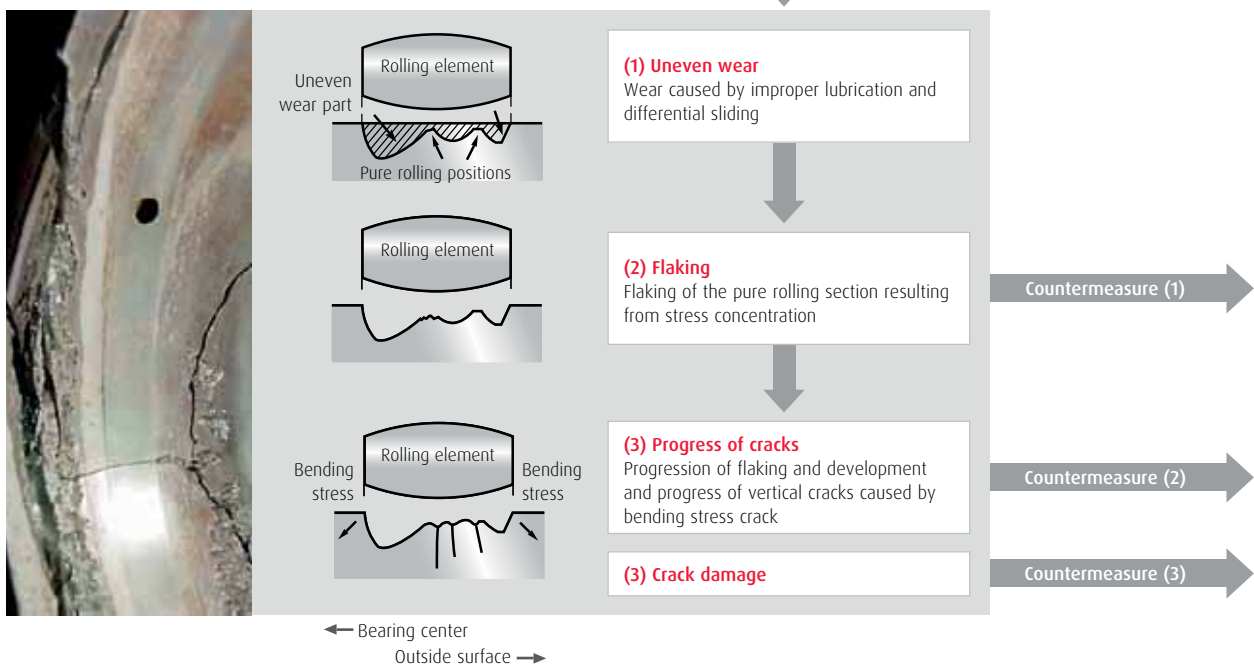
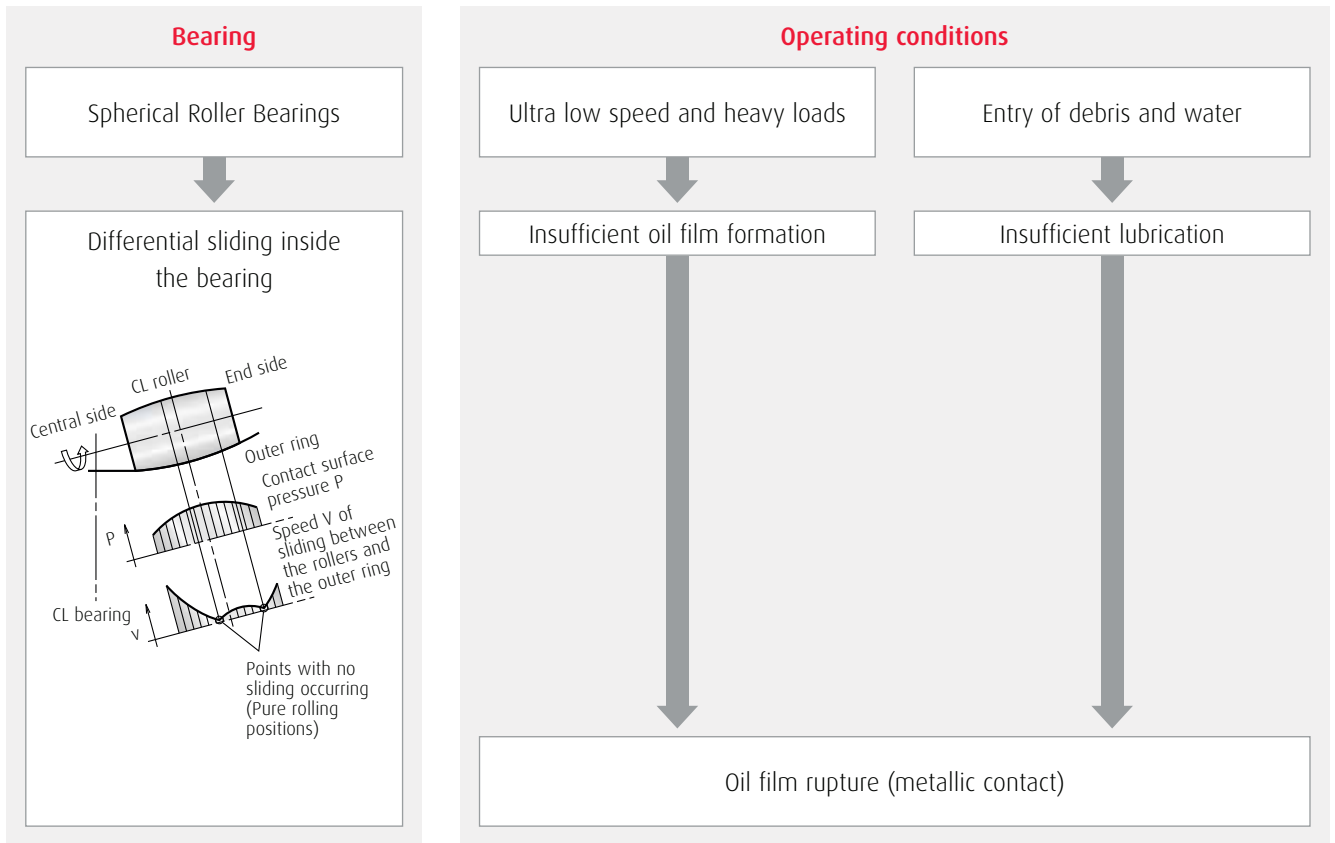



Development of SWR™ Bearings

Basic performance

Profile of wear on the outer ring raceway surface of Spherical Roller Bearings

Countermeasure (1): Wear resistance

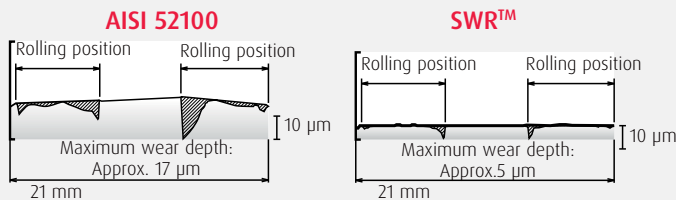

Wear resistance approx. 3 times

Evaluation of an endurance test using 22210CD bearings

Countermeasure (2): Improved flaking life (inhibition of flaking)

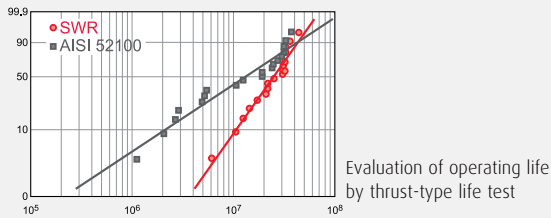

Bearing life approx. 5 times

Evaluation of operating life by thrust-type life test

Countermeasure (3): Improved outer ring strength

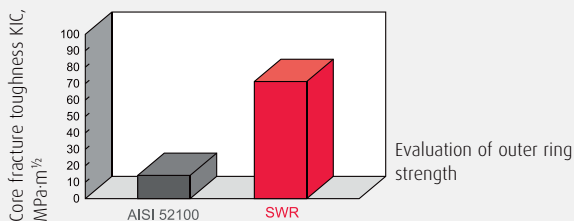

Core toughness approx. 5 times

Evaluation of outer ring strength

Development of wear-resistant materials

- › Selection of steel chemical composition
- › Applied special heat treatment technology
- › Controlled optimum level for retained austenite

Microstructure:

Result P-extraction replica work using transmission electron microscopy (TEM)

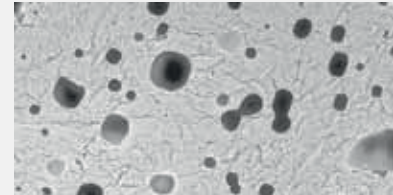

AISI 52100

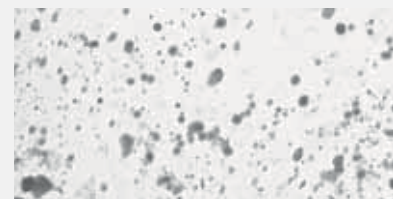

SWR™

Field endurance evaluation

Longer bearing life results in extended segment replacement cycles

SWR™ Bearings allow users, who have been forced to replace segments at frequent cycles due to the bearing life of standard spherical roller bearings, to attain maximum effect in reducing maintenance, by decreasing unexpected accidents and using rolls to the full extent of their operating life.

Standard Spherical Roller Bearings CASE 1 and 2*

Ø Average segment replacement cycles: 1

SWR™ Bearings CASE 1 and 2*

Ø Average segment replacement cycles: 1.6

Maximum: 2

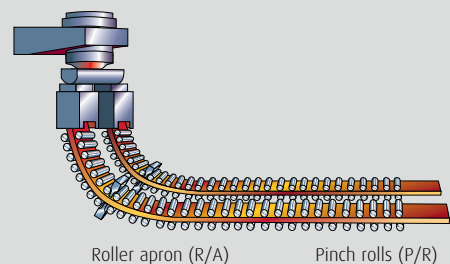

Roller apron (R/A)

Pinch rolls (P/R)

* see case 1 and 2 on pages 16-17



Development of tapered roller bearings and cylindrical roller bearings with aligning rings

Development of new type bearings

Comparison of PV value properties affecting the wear within the bearing

Surface pressure (P), Sliding (V), Wear property parameter: PV (PxV)

PV value between the outer ring raceway surface and roller raceway surface

PV value properties of

(1) Spherical Roller Bearing

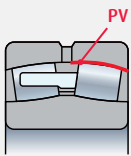

(2) Tapered roller bearing with aligning ring

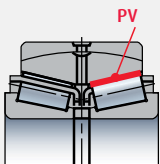

(3) Cylindrical roller bearing with aligning ring

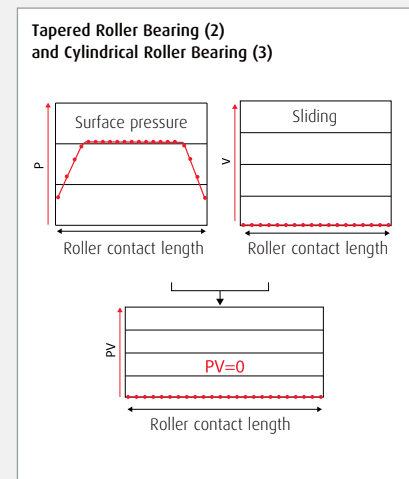
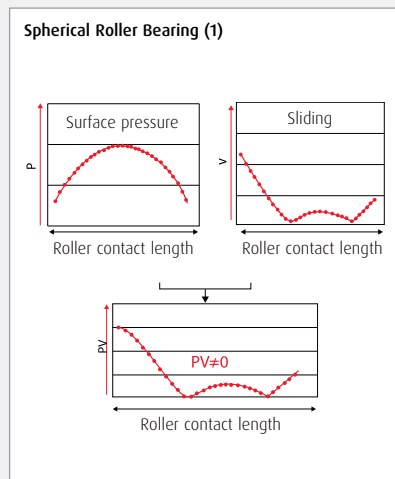
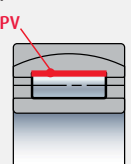

Field endurance evaluation

Wear evaluation

Example of inspection of an abrasion level on the outer ring raceway surface

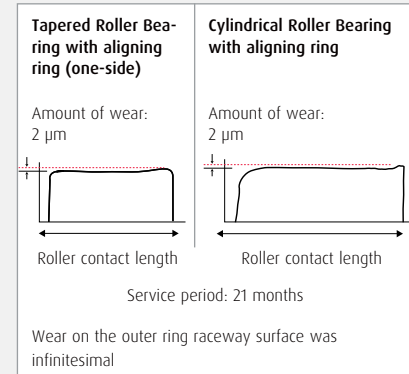
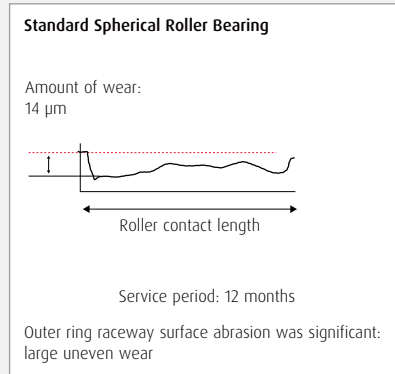



User Benefit

Estimated effect of maintenance cost reduction

Maintenance cost includes expenses for repairing of rolls, replacement of bearings, seal and fittings, as well as labor cost required on every segment replacement.

Standard bearings

Example: 24 months

	First	Second	Third
Frequency of segment maintenance			
Maintenance cost	Maintenance cost	Maintenance cost	Maintenance cost
Segment replacement cycles	1 (8 months)	1 (8 months)	1 (8 months)

SWR™ Bearings

Example: 26 months

	First	Second
Frequency of segment maintenance		
Maintenance cost	Maintenance cost	Maintenance cost
Segment replacement cycles	1.6 (13 months)	1.6 (13 months)

If SWR Bearings are used on 1-8 segments out of 15 segments of a 2-strand continuous casting machine, then segment life is extended on average 1.6 times. The estimated reduction effect is 20%-30% of total maintenance cost.

Bearings for Rolling Mills

Four-Row Tapered Roller Bearings for Work Rolls

1. Operating conditions

- › High speed/Low speed
- › Heavy loads
- › Vibration and Impact
- › High temperature
- › Scale
- › Water infiltration

Major target mills:

- › Hot strip mills
- › Skin pass mills
- › Cold rolling mills
- › Temper rolling mills

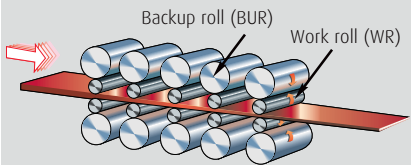

Tandem cold rolling mill

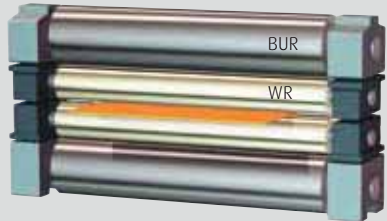

Conventional structure

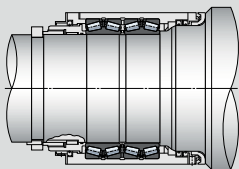

(1) Open type four-row tapered roller bearing

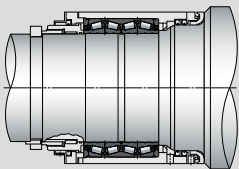

(2) Sealed four-row tapered roller bearing

2. Typical problems

(1) Open type four-row tapered roller bearings

(2) Sealed four-row tapered roller bearings

Large grease consumption and high maintenance costs

Premature failure due to poor lubrication

Operating conditions, including loading, debris and water infiltration become severe

Flaking



Seizure

High bearing usage cost

Unexpected production line failure



3. Countermeasures

Material measures

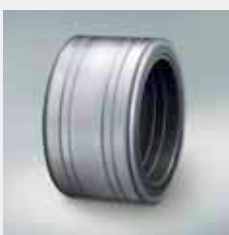

Water-TF™ Bearings – WTF Series*

- › Adoption of super-clean steel with optimum alloy balance controls development and progress of cracks at early flaking stage caused by water infiltration
- › Control of the retained austenite reduces concentration of stress resulting from dents caused by infiltration of debris

Water-TF Bearings are a special purpose bearing series in the same design as the standard KVS types (see below)

Optimum construction



Extra-Capacity Sealed-Clean™

Four-Row Tapered Roller Bearings – KVS Series**

- › Higher load capacity: increased by 15%-35% compared to conventional sealed bearings
- › Super-TF steel: resistant to foreign contamination, used as standard
- › Controlled negative pressure during rolling to prevent water infiltration
- › Improved sealing through usage of heat- and water-resistant sealing materials
- › Easier handling of seals

4. Benefits

- › Higher reliability and longer operating life prevent unexpected accidents
- › Bearing seal requires less cleaning of work environment and reduces grease consumption
- › Reduced maintenance costs

User Benefit page 28 – 29

Newly developed structure

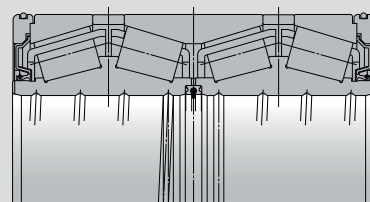

Extra-Capacity Sealed-Clean™
Four-Row Tapered Roller Bearings – KVS Series

* Bearing tables see page 38-39

** Bearing tables see page 40-41

Bearings for Rolling Mills

Four-Row Cylindrical Roller Bearings for Backup Rolls

1. Operating conditions

- › Vibration and Impact
- › Heavy loads
- › High temperature
- › High speed/Low speed

Major target mills:

- › Plate mills
- › Skin pass mills
- › Hot strip mills
- › Temper rolling mills
- › Cold rolling mills

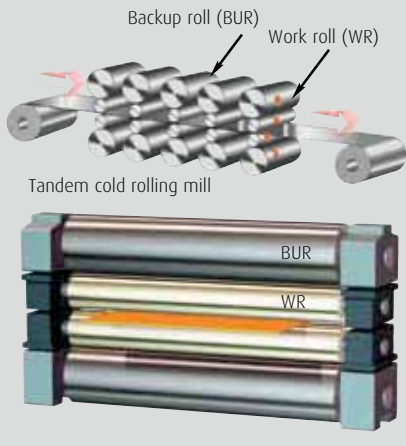

Conventional structure

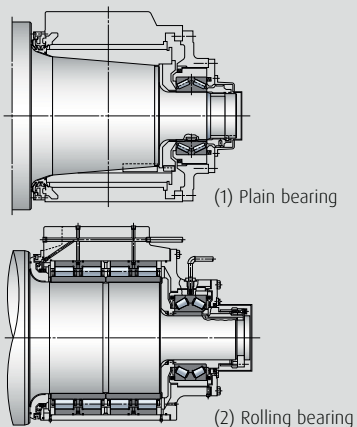

2. Typical problems

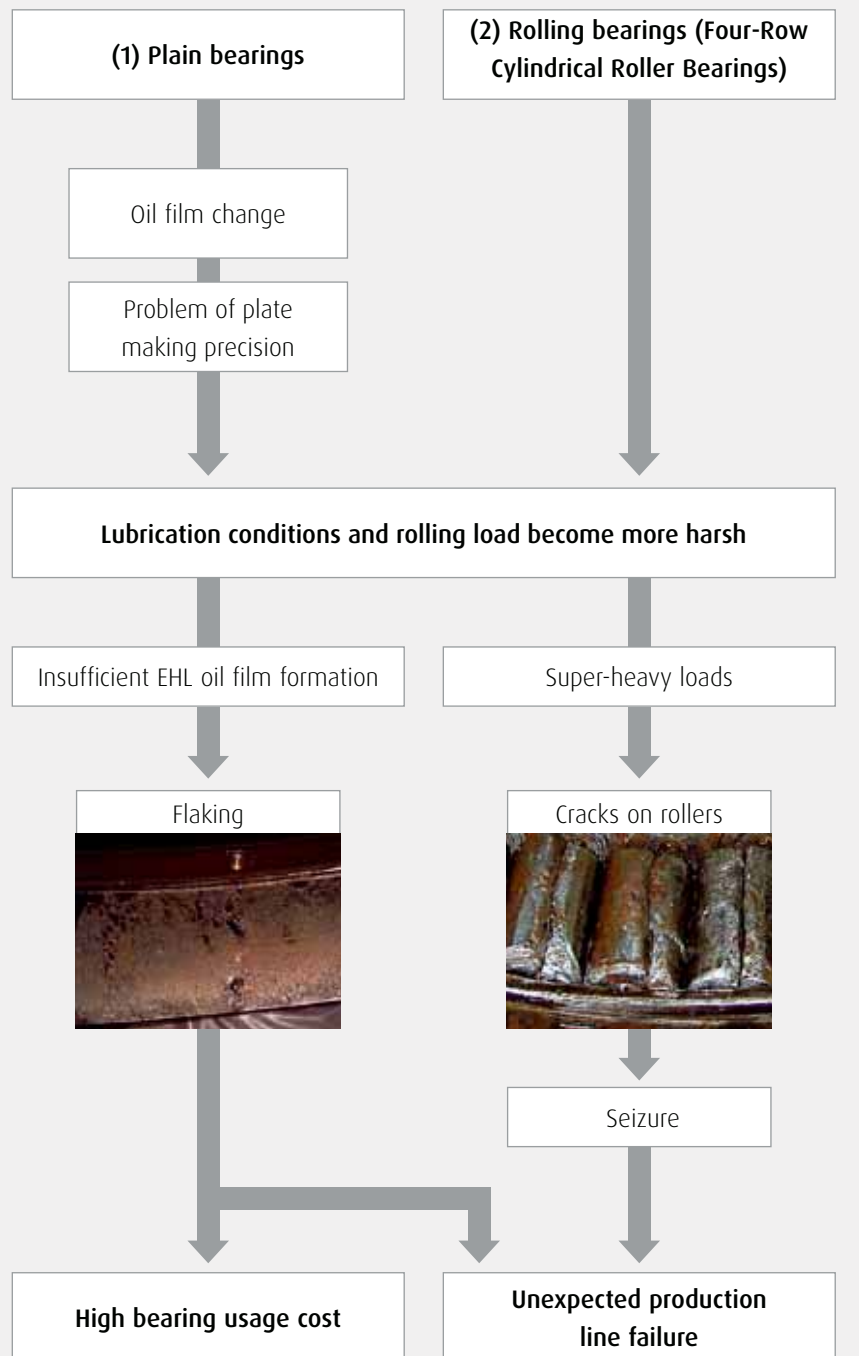



3. Countermeasures

Design measures



Super-TF™ Four-Row Cylindrical Roller Bearings – STF-RV Series*

- › Longer life Super-TF steel, resulting in longer durability, even under boundary-lubrication with insufficient EHL oil film formation
- › Higher load capacity by using pin type cage
- › Higher rotational accuracy

Bearing usage cost reduced by 50%



Super-TF™ Four-Row Cylindrical Roller Bearings – STF-RV stud type**

- › Target: Bearings for backup rolls of plate mills
- › Adoption of solid type rollers associated with the development of a stud-type cage
- › Higher load capacity
- › Adoption of long-life Super-TF steel
- › Higher rotational accuracy

Elimination of unexpected accidents caused by cracks on rollers

4. Benefits

- › Higher reliability and longer operating life prevent unexpected accidents
- › Reduced maintenance costs
- › Smoother rolling of bearings for backup rolls improves plate making precision

Comparison of actual life extension in field test

- › Conventional steel = 1
- › Super TF steel = 2

Previous	1
New	2

Newly developed structure

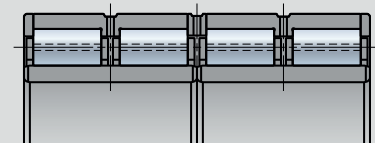

STF-RV-Series

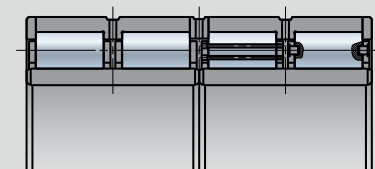

STF-RV (stud type)

* Bearing tables see page 42

** Bearing tables see page 43

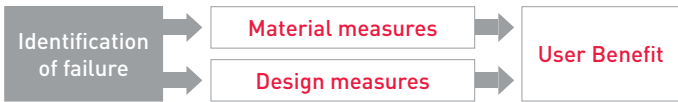

Identification of the failure mechanism

Failure mechanism of the four-row tapered roller bearings for work rolls for rolling mills

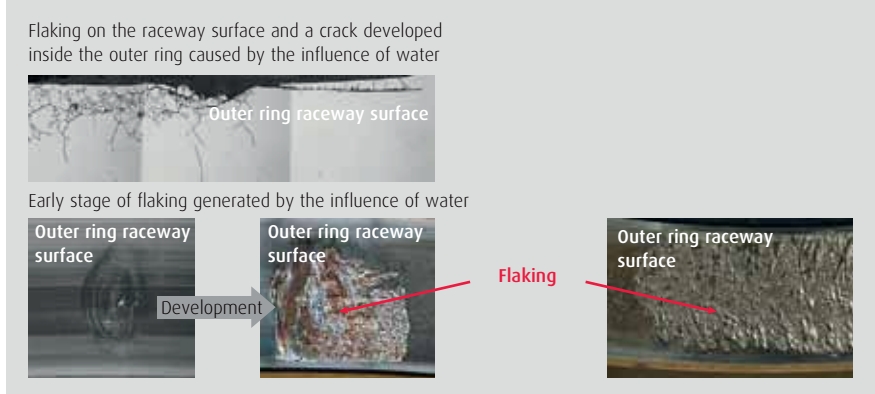
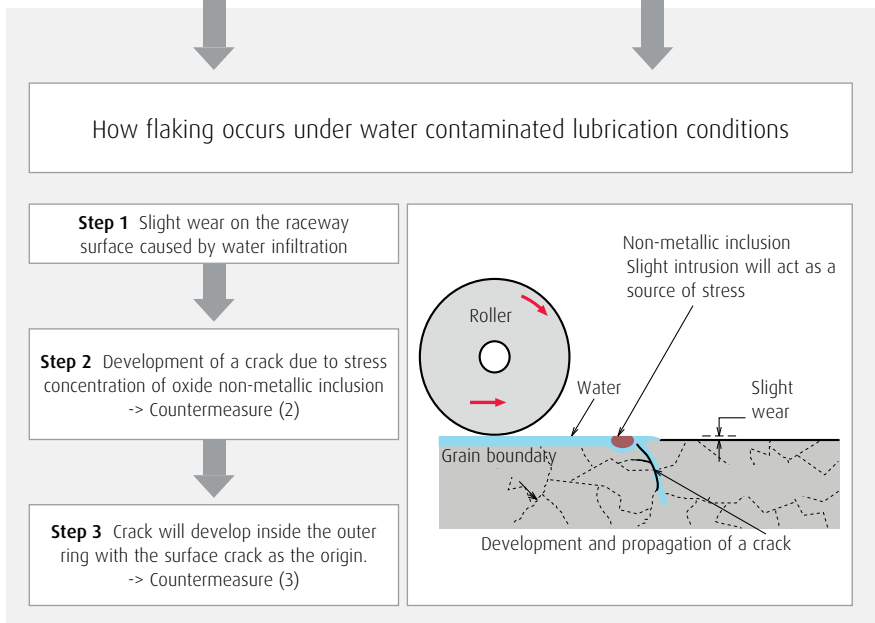
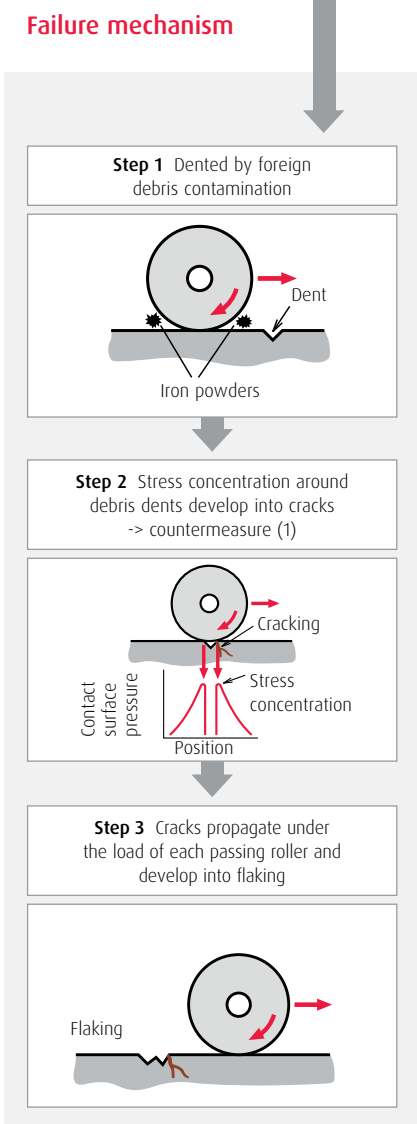
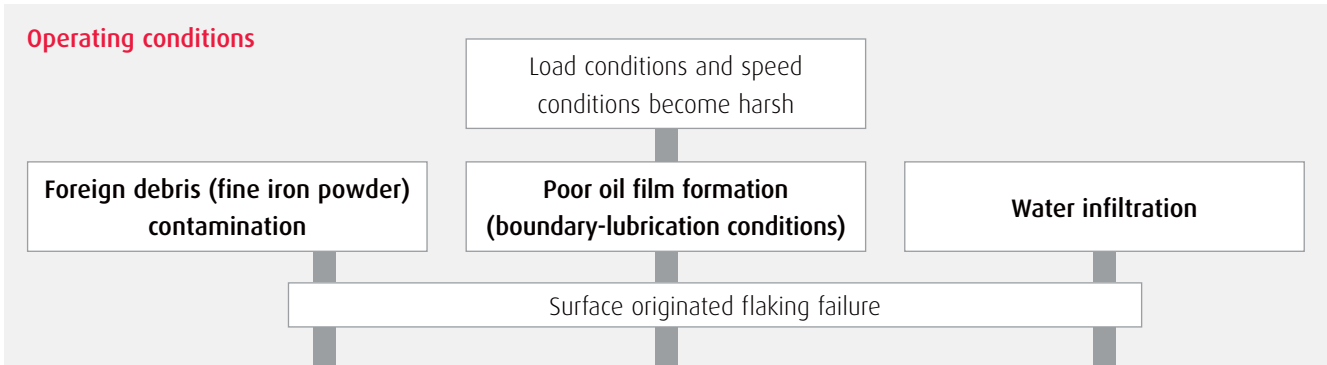



Development of Super-TF™ Bearing and Water-TF® Bearing

Enhances reliability and reduces maintenance cost of rolling mills

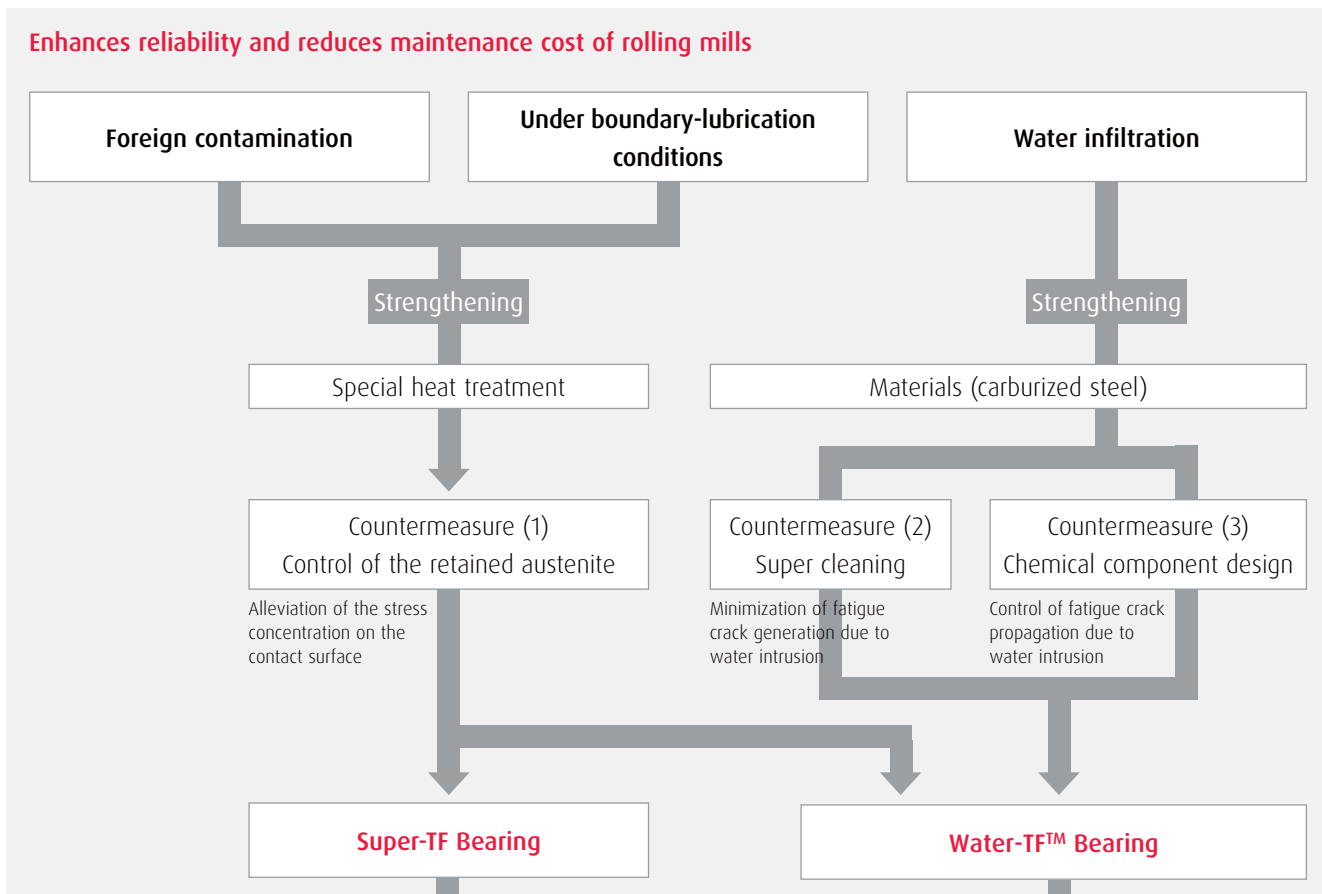

Basic performance

Life of Super-TF Bearings under lubrication with foreign contamination and under boundary-lubrication

1. Life test result under foreign contamination (tapered roller bearings)

Catalogue life	1
General carburized steel	0,2
Super-TF	2

2. Life test result under boundary-lubrication ($\Delta=0,3$) (ball-rod rollingcontact fatigue test)

General carburized steel	1
Super-TF	5,5

Life of Water-TF™ Bearings under lubrication with water and foreign contamination

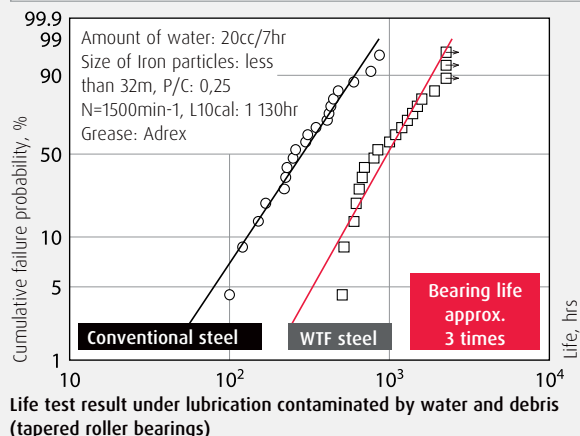



Development of Extra-Capacity Sealed-Clean™ Four-Row Tapered Roller Bearings (KVS Series)

Design measures

High-load capacity design

New internal structure specifications, combined with a new type of seal, increase bearing capacity (patent pending).

New seal and holder

The new seal and its holder make handling easier and minimize seal damage (patent pending).

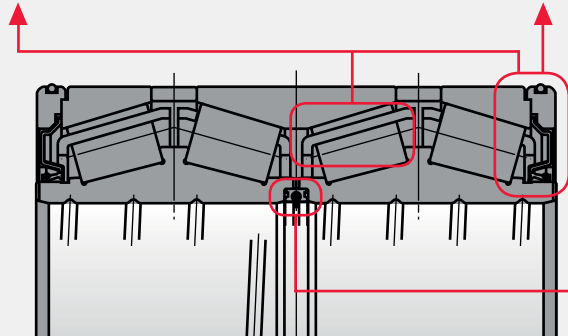

New bore seal

The new bore seal prevents negative pressure that causes water entry and provides for easier mounting and dismounting (patents pending).

KVS Series

Basic load rating (C_r):

15-35% increase

Estimated life (L_{10}):

1.6 to 2.7 times of estimated life extension

Performance of the bearing seal (Control of negative pressure inside the bearing):

Negative pressure and water infiltration were reduced to less than 1/3

Field durability performance

- Target equipment: tandem cold rolling mills (4-high)
- Segment example: work rolls
- Bearing type: sealed four-row tapered roller bearings (Fig.1)
- Bearing No.: WTF343KVS4551

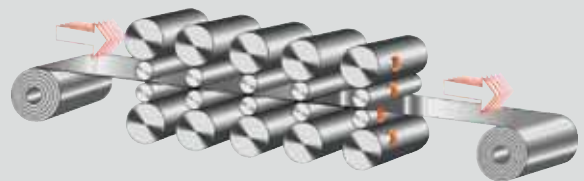

Average life ratios of bearings for work rolls

Conventional type sealed bearings	1
Water-TF™ Bearings	3

Water-TF™ Bearings demonstrated on average a three times longer life span for users who previously had been faced with bearings with short life spans due to water infiltration.

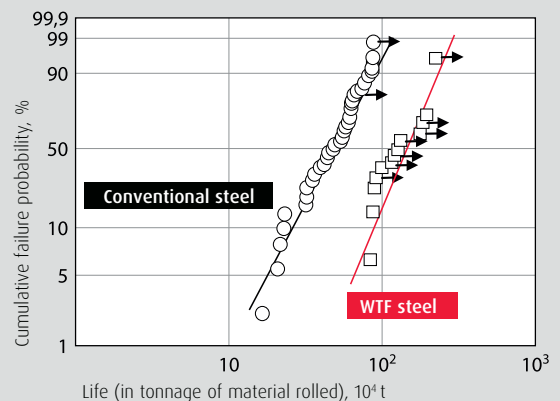



User Benefit

Estimated effect of maintenance cost reduction

Bearing specifications	Grease	Bearing usage cost and seal repair cost	Maintenance work cost for bearings
Open type bearings (without seal) Maintenance cycle: 3 months			
Conventional sealed bearings Maintenance cycle: 6 months	90% reduction		50% reduction
Water-TF™ Bearings Maintenance cycle: 6 months	90% reduction	50% reduction	50% reduction

Overall cost benefit in a five-stand cold rolling mill (four-high rolling) using Water-TF Bearings is roughly 30% to 35% compared to open-type bearings and maintenance cost benefit is roughly 25% to 30% if compared to conventional sealed bearings. Cost benefit is the sum of costs related to grease, bearing usage, seal repair, and maintenance costs ((1) + (2) + (3)).

Dimensions of Bearings for Sintering Equipment

Sealed-Clean Bearings for Pallet Wheels - AR Series

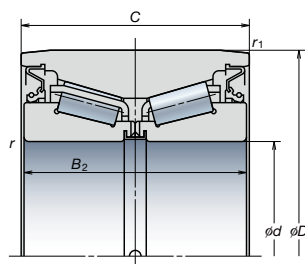

Bearing Numbers	Boundary Dimensions (mm)						Basic Load Ratings (kN)	
	d	D	B ₂	C	r (min)	r ₁ (min)	C _r	C _{0r}
AR80-24	80	150	67	67	2.5	1.0	269	390
AR90-25	90	160	74	74	2.5	0.5	240	435
AR90-26	90	160	80	80	2.5	0.5	240	435
AR90-27	90	160	78	78	2.5	0.5	240	435
AR100-29	100	180	98	100	2.5	1.0	350	675
AR100-30	100	180	100	100	2.5	1.0	350	675
AR100-38	100	180	100	100	3.0	0.5	525	835
AR100-40	100	180	98	100	3.0	0.5	525	835
AR110-28	110	180	86	86	3.0	0.5	330	660
AR110-29	110	200	92	100	2.5	1.0	415	805
AR110-39	110	200	100	100	3.0	1.0	570	950

Remarks: Other bearings are available. Please contact NSK for additional information.

Sealed-Clean Bearings for Inboard Rollers - 2J Series

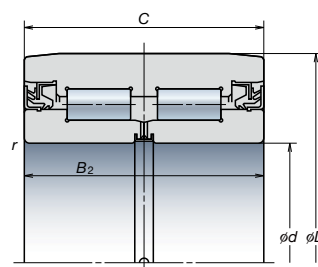

Bearing Numbers	Boundary Dimensions (mm)					Basic Load Ratings (kN)	
	d	D	B ₂	C	r (min)	C _r	C _{0r}
2J100-2	100	200	120	119	2.1	315	910
2J120-9A	120	210	120	120	2.5	610	1 080
2J120-14	120	210	132	132	2.1	530	1 320
2J140-2	140	250	130	130	4.0	770	1 420
2J160Z-1	160.11	250	130	130	2.5	670	1 540
2J160Z-5	160.11	250	155	150	2.1	610	2 050

Remarks: Other bearings are available. Please contact NSK for additional information.

Dimensions of Bearings for BOFs and Converters



Ultra-Large Split Bearings for BOFs and Converter Trunnions

Bearing Numbers	Boundary Dimensions (mm)									Basic Load Ratings (kN)		Fig.
	d	D	B	b	b ₁	D ₁	D _u	r ₁ (min)	r ₂ (min)	C _r	C _{or}	
750SLPT1051	750	1 000	250	355	-	905	914.4	6.0	7.5	6 800	18 300	1
SL850-7	850	1 120	272	385	-	1 015	1 025	6.0	6.0	8 000	21 600	1
900SLPT1251	900	1 250	285	410	-	1 100	1 142	7.5	19.0	9 850	24 200	1
950SLPT1451	950	1 400	300	520	600	1 182	1 265	7.5	28.0	12 300	27 900	2
SL1120-3	1 120	1 580	320	632.5	697.5	1 400	1 445	9.5	30.0	13 200	32 000	2
1200SLPT1751	1 200	1 700	410	780	780	1 470	1 536	9.5	31.0	17 300	43 500	2
1200SLPT1752	1 200	1 700	410	660	730	1 470	1 536	9.5	19.0	17 300	43 500	2
1320SLPT1851	1 320	1 850	530	815	814	1 600	1 670	12.0	31.0	22 500	63 500	2
1400SLPT1951	1 400	1 900	530	880	880	1 680	1 710	12.0	31.0	22 800	65 000	2
1400SLPT1953	1 400	1 900	530	810	860	1 680	1 710	12.0	31.0	22 800	65 000	2

Remarks: 1. The shapes of bearings marked * are not exactly the same as shown in Fig. 2.
2. Other bearings are available. Please contact NSK for additional information.

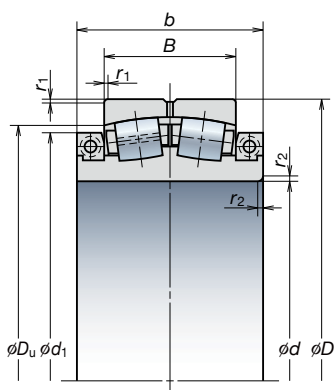

Fig. 1

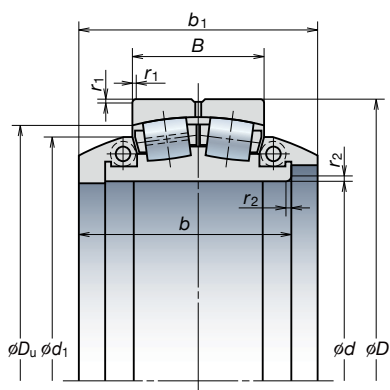

Fig. 2 Clamp ring with tangential seal surface

Dimensions of Bearings for Continuous Casting Machines

SWR™ Bearings (Spherical Roller Bearings) - SWR™-Series

Bearing Numbers	Boundary Dimensions (mm)				Basic Load Ratings (kN)		Fig.
	d	D	B	r (min)	C _r	C _{or}	
22208SWREAg2E4	40	80	23	1.1	113	99.5	1
22210SWREAg2E4	50	90	23	1.1	124	119	1
23012SWRCgE4	60	95	26	1.1	98.5	141	3
22212SWREAg2E4	60	110	28	1.5	178	174	1
22214SWREAg2E4	70	125	31	1.5	225	232	1
22216SWREAg2E4	80	140	33	2.0	264	275	1
22218SWREAg2E4	90	160	40	2.0	360	395	1
23020SWRCDg2E4	100	150	37	1.5	212	335	3
24020SWRCg2E4	100	150	50	1.5	276	470	3
24120SWRCg2ME4	100	165	65	2.0	345	535	2
22220SWREAg2E4	100	180	46	2.1	455	490	1
23022SWRCDg2E4	110	170	45	2.0	293	465	3
24022SWRCg2E4	110	170	60	2.0	380	645	3
24122SWRCg2E4	110	180	69	2.0	460	750	3
22222SWREAg2E4	110	200	53	2.1	605	645	1
23024SWRCDg2E4	120	180	46	2.0	315	525	3
24024SWRCg2E4	120	180	60	2.0	395	705	3
24124SWRCg2E4	120	200	80	2.0	575	950	3
22224SWREAg2E4	120	215	58	2.1	685	765	1
23026SWRCDg2E4	130	200	52	2.0	400	655	3
24026SWRCg2E4	130	200	69	2.0	495	865	3
24126SWRCgE4	130	210	80	2.0	590	1 010	3
22226SWREAg2E4	130	230	64	3.0	820	940	1
23028SWRCDg2E4	140	210	53	2.0	420	715	3
24028SWRCg2E4	140	210	69	2.0	525	945	3
24128SWRCg2E4	140	225	85	2.1	670	1 160	3
22228SWRCDg2E4	140	250	68	3.0	645	930	3

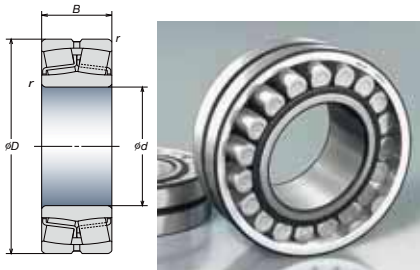

Fig. 1 (EA)

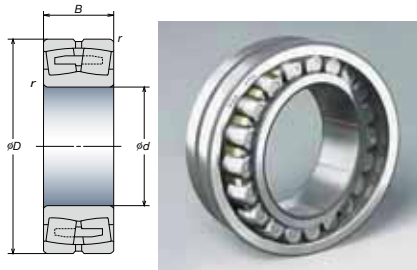

Fig. 2 (CAM)

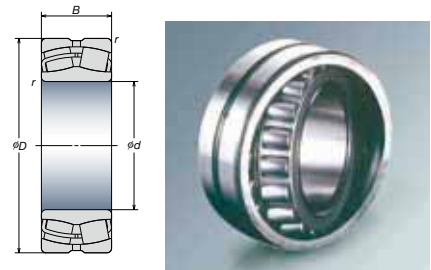

Fig. 3 (CD)

Bearing Numbers	Boundary Dimensions (mm)				Basic Load Ratings (kN)		Fig.
	d	D	B	r (min)	C _r	C _{0r}	
23030SWRCDg2E4	150	225	56	2.1	470	815	3
24030SWRCg2E4	150	225	75	2.1	590	1 090	3
24130SWRCgwE4	150	250	100	2.1	890	1 530	3
22230SWRCg2E4	150	270	73	3.0	765	1 120	3
23032SWRCDg2E4	160	240	60	2.1	540	955	3
24032SWRCg2E4	160	240	80	2.1	680	1 260	3
24132SWRCg2E4	160	270	109	2.1	1 040	1 760	3
22232SWRCDg2E4	160	290	80	3.0	910	1 320	3
23034SWRCDg2E4	170	260	67	2.1	640	1 090	3
24034SWRCg2E4	170	260	90	2.1	825	1 520	3
24134SWRCg2E4	170	280	109	2.1	1 080	1 860	3
22234SWRCDg2E4	170	310	86	4.0	990	1 500	3
23036SWRCDg2E4	180	280	74	2.1	750	1 270	3
24036SWRCg2E4	180	280	100	2.1	965	1 750	3
24136SWRCg2E4	180	300	118	3.0	1 190	2 040	3
22236SWRCDg2E4	180	320	86	4.0	1 020	1 540	3
23038SWRCAg2ME4	190	290	75	2.1	775	1 350	2
24038SWRCg2E4	190	290	100	2.1	975	1 840	3
24138SWRCg2E4	190	320	128	3.0	1 370	2 330	3
22238SWRCAg2ME4	190	340	92	4.0	1 140	1 730	2
23040SWRCAg2Me4	200	310	82	2.1	940	1 700	2
24040SWRCg2E4	200	310	109	2.1	1 140	2 120	3
24140SWRCg2E4	200	340	140	3.0	1 570	2 670	3
22240SWRCAg2ME4	200	360	98	4.0	1 300	2 010	2
23044SWRCAg2ME4	220	340	90	3.0	1 090	1 980	2
24044SWRCgE4	220	340	118	3.0	1 360	2 600	3
24144SWRCg2E4	220	370	150	4.0	1 800	3 200	3
22244SWRCAg2ME4	220	400	108	4.0	1 570	2 430	2

Remarks: Other bearings are available. Please contact NSK for additional information.

Dimensions of Bearings for Continuous Casting Machines

Cylindrical Roller Bearings with Aligning Rings (With cage) – RUB Series

RUB Series (With cage)

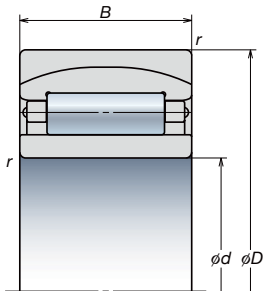

Bearing Numbers	Boundary Dimensions (mm)				Basic Load Ratings (kN)		
	Free End	d	D	B	r (min)	C _r	C _{0r}
110RUB41		110	180	69	2.0	271	490
120RUB40		120	180	60	2.0	247	495
120RUB41		120	200	80	2.0	370	680
120RUB32		120	215	76	2.1	435	735
130RUB41		130	210	80	2.0	380	715
130RUB32		130	230	80	3.0	490	825
140RUB40		140	210	69	2.0	330	670
140RUB41		140	225	85	2.1	435	830
150RUB40		150	225	75	2.1	375	755
150RUB41		150	250	100	2.1	540	1 040
150RUB32		150	270	96	3.0	690	1 210
160RUB41		160	270	109	2.1	690	1 260
160RUB32		160	290	104	3.0	795	1 370
170RUB41		170	280	109	2.1	710	1 330
170RUB32		170	310	110	4.0	915	1 590
180RUB40		180	280	100	2.1	635	1 300
180RUB41		180	300	118	3.0	755	1 460
190RUB41		190	290	100	2.1	650	1 360
190RUB32		190	340	120	4.0	1 050	1 870
200RUB40		200	310	109	2.1	770	1 540
200RUB41		200	340	140	3.0	1 080	2 200

RUB-Series (Full-complement)

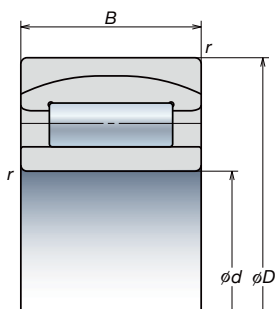

Bearing Numbers	Boundary Dimensions (mm)				Basic Load Ratings (kN)		
	Free End	d	D	B	r (min)	C _r	C _{0r}
110RUB41APV		110	180	69	2.0	375	805
110RUB32APV		110	200	69.8	2.1	440	805
120RUB40APV		120	180	60	2.0	305	715
120RUB41APV		120	200	80	2.0	450	958
120RUB32APV		120	215	76	2.1	510	990
130RUB40APV		130	200	69	2.0	405	935
130RUB41APV		130	210	80	2.0	480	1 050
130RUB32APV		130	230	80	3.0	585	1 090
140RUB40APV		140	210	69	2.0	420	990
140RUB41APV		140	225	85	2.1	454	1 230
140RUB32APV		140	250	88	3.0	715	1 390
150RUB40APV		150	225	75	2.1	435	1 070
150RUB41APV		150	250	100	2.1	710	1 620
150RUB32APV		150	270	96	3.0	815	1 640
160RUB40APV		160	240	80	2.1	490	1 200
160RUB41APV		160	270	109	2.1	855	1 830
160RUB32APV		160	290	104	3.0	960	1 890
170RUB40APV		170	260	90	2.1	640	1 520
170RUB41APV		170	280	109	2.1	875	1 900
170RUB32APV		170	310	110	4.0	1 060	2 090
180RUB40APV		180	280	100	2.1	758	1 870
180RUB41APV		180	300	118	3.0	940	2 120
180RUB32APV		180	280	112	4.0	1 090	2 190
190RUB40APV		190	300	100	2.1	810	1 980
190RUB41APV		190	320	128	3.0	1 120	2 480
190RUB32APV		190	340	120	4.0	1 210	2 430
200RUB40APV		200	310	109	2.4	960	2 250
200RUB41APV		200	340	140	3.0	1 300	2 930
200RUB32APV		200	360	128	4.0	1 320	2 760

Tapered Roller Bearings with Aligning Rings – AR Series

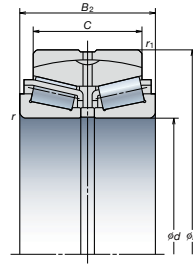

Bearing Numbers	Boundary Dimensions (mm)						Basic Load Ratings (kN)		
	Free End	d	D	B ₂	C	r (min)	r ₁ (min)	C _r	C _{or}
AR80-31		80	140	46	33	2.0	2.0	144	205
AR90-34		90	190	64	58	3.0	3.0	300	430
AR100-42		100	180	60	46	2.1	2.1	256	390
AR110-46		110	170	45	38	2.0	2.5	171	310
AR120-30		120	180	60	48	2.0	2.5	256	525
AR130-31		130	200	69	55	2.0	2.5	320	650
AR130-37		130	230	95	80	3.0	3.0	530	1 010
AR140-24		140	210	69	55	2.5	2.5	340	690
AR140-27		140	225	85	70	2.1	2.1	445	905
AR140-28		140	225	68	54	2.5	2.5	385	620
AR140-29		140	210	53	43	2.0	2.5	252	460
AR150-1		150	225	75	60	2.5	2.5	395	845
AR160-11		160	240	80	65	2.1	2.1	455	935
AR180-1		180	280	100	80	3.0	2.5	665	1 430
AR200-18		200	340	112	92	3.0	3.0	895	1 630

Remarks: Other bearings are available. Please contact NSK for additional information.

Dimensions of Bearings for Continuous Casting Machines

Split Cylindrical Roller Bearings (for segmented rolls) – RNP-RNPH Series

Bearing Numbers		Boundary Dimensions (mm)					Roll diameter d ₁	Basic Load Ratings (kN)		Guide Roll		axial tolerance (mm)
Housing	Bearing	d	B ₁	r	L	H		C _r	C _{0r}	roll length	Radius r ₁	
100RCPH171	100PHR211	100	154	18	200	145	210	405	950	155	18	19.0
100RCPH201	100PHR231	100	169	15	235	132	225	605	1 390	170	15	8.0
110RCPH181	110PHR221	110	139	15	220	225	220	450	1 090	140	15	9.0
110RCPH191	110PHR231	110	137	15	230	160	230	480	1 120	138	15	8.0
110RCPH192	110PHR232	110	154	20	230	150	230	525	1 280	155	20	8.0
110RCPH193	110PHR233	110	154	20	230	180	225	500	1 200	155	20	10.0
110RCPH201	110PHR234	110	154	20	230	180	230	540	1 270	155	20	10.0
115RCPH201	115PHR241	115	173	20	240	220	240	600	1 400	174	15	6.0
120RCPH181	120PHR221	120	163	20	220	145	220	360	965	164	20	10.5
120RCPH182	120PHR222	120	164	20	220	160	220	360	965	165	20	10.5
120RCPH201	120PHR231	120	157	15	234	165	235	540	1 340	158	20	8.0
120RCPH211	120PHR251	120	151	20	250	180	250	610	1 430	152	20	6.0
120RCPH212	120PHR251	120	151	20	250	190	250	525	1 310	152	20	10.0
120RCPH213	120PHR253	120	153	20	250	145	250	560	1 340	154	20	9.0
120RCPH214	120PHR254	120	154	20	250	180	250	565	1 380	155	20	8.0
120RCPH215	120PHR255	120	154	20	250	190	250	570	1 400	155	20	10.0
120RCPH216	120PHR256	120	179	20	255	230	255	630	1 580	180	20	8.0
130RCPH201	130PHR241	130	184	20	240	175	240	455	1 320	185	20	10.5
130RCPH221	130PHR261	130	157	20	270	180	260	615	1 520	158	20	6.0
130RCPH221	130PHR271	130	154	20	270	190	270	545	1 420	155	20	10.0
130RCPH222	130PHR272	130	154	20	270	190	270	585	1 480	155	20	9.0
130RCPH223	130PHR262	130	145	18	265	145	250	545	1 270	146	18	7.5
130RCPH224	130PHR263	130	157	20	265	180	265	625	1 530	158	20	6.0
130RCPH231	130PHR273	130	143	20	270	197	250	555	1 270	144	20	6.0
130RCPH232	130PHR281	130	174	20	280	160	280	760	1 890	175	20	9.0

Remarks: Other bearings are available. Please contact NSK for additional information.

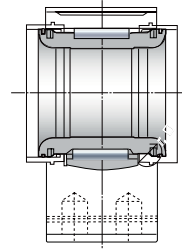

Bearing Numbers		Boundary Dimensions (mm)					Roll diameter d ₁	Basic Load Ratings (kN)		Guide Roll		axial tolerance (mm)
Housing	Bearing	d	B ₁	r	L	H		C _r	C _{or}	roll length	Radius r ₁	
135RCPH211	135PHR251	135	183	20	250	160	250	515	1 350	184	20	10.0
140RCPH221	140PHR261	140	184	20	260	185	260	565	1 410	185	20	10.5
140RCPH222	140PHR262	140	174	20	265	242.5	265	620	1 590	175	20	9.0
140RCPH223	140PHR263	140	191	20	265	250	265	615	1 570	192	20	6.0
140RCPH231	140PHR271	140	179	20	270	245	270	665	1 750	180	20	6.0
140RCPH232	130PHR281	140	159	25	270	180	280	615	1 590	160	25	8.0
140RCPH233	140PHR282	140	163	20	280	180	280	665	1 610	164	20	6.0
140RCPH261	140PHR311	140	184	20	310	175	310	840	1 970	185	20	9.0
145RCPH231	145PHR281	145	179	20	280	250	280	680	1 860	180	20	8.0
145RCPH232	145PHR282	145	196	20	280	260	280	675	1 800	197	20	6.0
145RCPH233	145PHR283	145	196	20	280	250	280	675	1 800	197	20	10.0
145RCPH251	145PHR291	145	208	20	295	270	295	880	2 230	209	20	6.0
150RCPH251	150PHR291	150	208	20	295	310	295	754	1 870	209	20	6.0
150RCPH252	150PHR301	150	169	20	295	180	300	715	1 880	170	20	9.0
150RCPH271	150PHR321	150	187	20	320	220	320	955	2 320	188	20	9.0
155RCPH251	155PHR301	155	199	20	300	260	300	770	1 970	200	20	8.0
160RCPH261	160PHR311	160	199	20	310	270	320	845	2 270	200	20	9.0
160RCPH281	160PHR331	160	200	20	330	225	320	1 070	2 650	201	20	7.0
160RCPH271	160PHR321	165	228	25	320	280	320	925	2 440	229	25	6.0
170RCPH271	170PHR321	170	214	20	320	255	330	855	2 330	215	20	10.0
170RCPH281	170PHR331	170	235	25	330	280	330	1 100	2 870	236	25	6.0
180RCPH281	180PHR341	180	235	25	340	280	340	980	2 490	236	25	6.0
180RCPH291	180PHR331	180	169	20	335	217.5	335	780	1 800	170	20	8.0
190RCPH331	190PHR391	190	233	20	390	280	370	1 510	3 850	234	20	6.0

Remarks: Other bearings are available. Please contact NSK for additional information.

Dimensions of Bearings for Rolling Mills

Water-TF® Bearings – WTF-Series

Bearing Numbers	Boundary Dimensions (mm/inch)						Basic Load Ratings (kN)		Constant e	Axial Load Factors	
	d	D	B_4	C_4	r (min)	r_1 (min)	C_r	C_{0r}		Y_2	Y_3
WTF170KVS2401Eg	170	240	175	175	2.5	2.5	1 020	2 010	0.32	3.2	2.1
*WTF215KVS2851Eg	215.900 (8.5000)	288.925 (11.750)	177.800 (7.0000)	177.800 (7.0000)	3.3	0.8	1 070	2 350	0.49	2.1	1.4
*WTF216KVS3351Eg	216.103 (8.5080)	330.2 (13.0000)	263.525 (10.3750)	263.525 (10.3750)	3.3	1.5	2 290	4 550	0.46	2.2	1.5
WTF220KVS3301Eg	220	330	260	260	3.0	4.0	2 330	4 800	0.40	2.5	1.7
*WTF234KVS3251Eg	234.950 (9.2500)	327.025 (12.8750)	196.850 (7.7500)	196.850 (7.7500)	3.3	1.5	1 550	3 200	0.46	2.2	1.5
*WTF244KVS3215Eg	244.475 (9.6250)	327.025 (12.8750)	193.680 (7.6250)	193.680 (7.6250)	3.0	1.5	1 370	3 050	0.40	2.5	1.7
WTF245KVS3402Eg	245	345	310	310	3.0	2.0	2 700	6 650	0.40	2.5	1.7
*WTF254KVS3552Eg	254.000 (10.0000)	358.775 (14.1250)	269.875 (10.6250)	269.875 (10.6250)	3.3	1.5	2 420	5 500	0.40	2.5	1.7
WTF260KVS3601Eg	260	365	340	340	4.0	2.7	2 960	7 350	0.40	2.5	1.7
WTF260KVS3651Eg	260	365	340	340	4.0	2.5	2 960	7 350	0.40	2.5	1.7
*WTF260KVS4251Eg	260.350 (10.2500)	422.275 (16.6250)	314.325 (12.3750)	314.325 (12.3750)	3.3	6.4	3 600	7 050	0.33	3.0	2.0
*WTF266KVS3551Eg	266.700 (10.5000)	355.600 (14.0000)	230.188 (9.0625)	230.188 (9.0625)	3.3	1.5	1 960	4 600	0.35	2.9	1.9
*WTF76KVS3952Eg	276.225 (10.8750)	393.700 (15.5000)	269.875 (10.6251)	269.875 (10.6251)	3.3	1.5	2 720	6 100	0.45	2.2	1.5
*WTF279KVS3952Eg	279.400 (11.0000)	393.700 (15.5000)	269.875 (10.6251)	269.875 (10.6251)	6.4	1.5	2 720	6 100	0.45	2.2	1.5
*WTF279KVS3954Eg	279.4	393.7	320	320	6.4	1.5	3 100	7 350	0.40	2.5	1.7
WTF290KVS4001Eg	290	400	346	346	4.0	3.0	3 250	8 400	0.40	2.5	1.7
*WTF304KVS4351Eg	304.648 (11.9940)	438.048 (17.2460)	280.990 (11.6260)	280.990 (11.6260)	3.3	3.3	3 100	6 750	0.45	2.2	1.5
*WTF304KVS4155Eg	304.800 (12.0000)	419.100 (16.5000)	269.875 (10.6250)	269.875 (10.6250)	3.0	1.5	2 850	6 550	0.33	3.0	2.0
*WTF304KVS4152Eg	304.902 (12.0040)	412.648 (12.6250)	266.700 (10.50000)	266.700 (10.50000)	3.0	1.5	2 760	6 500	0.33	3.0	2.0
WTF310KVS4301Eg	310	430	310	310	3.3	3.0	3 350	8 200	0.46	2.2	1.5
WTF310KVS4302Eg	310	430	350	350	3.3	2.7	3 700	9 550	0.46	2.2	1.5
*WTF317KVS4251Eg	317.500 (12.5000)	422.275 (16.6250)	269.875 (10.6250)	269.875 (10.6250)	3.3	1.5	2 740	6 750	0.34	3.0	2.0

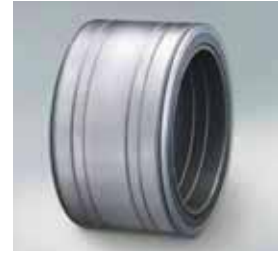

Bearing Numbers	Boundary Dimensions (mm/inch)						Basic Load Ratings (kN)		Constant e	Axial Load Factors	
	d	D	B ₄	C ₄	r (min)	r ₁ (min)	C _r	C _{0r}		Y ₂	Y ₃
*WTF343KVS4551Eg	340.052 (13.5060)	457.098 (17.9960)	254.000 (10.0000)	254.000 (10.0000)	3.3	1.5	2 830	6 700	0.45	2.2	1.5
*WTF355KVS4551Eg	355.600 (14.0000)	457.200 (18.0000)	252.412 (9.9375)	252.412 (9.9375)	3.3	1.5	2 650	6 750	0.32	3.2	2.1
*WTF406KVS5451Eg	406.400 (16.0000)	546.100 (21.5000)	288.925 (11.3750)	288.925 (11.3750)	6.4	1.5	3 950	9 450	0.48	2.1	1.4
WTF450KVS5901Eg	450	595	368	368	5.0	4.0	5 550	15 000	0.33	3.0	2.0
*WTF457KVS5951Eg	457.200 (18.0000)	596.900 (23.5000)	276.225 (10.8750)	276.225 (10.8750)	3.3	1.5	4 000	9 850	0.47	2.2	1.4
WTF482KVS6151Eg	482.600 (19.0000)	615.950 (24.2500)	330.200 (13.0000)	330.200 (13.0000)	6.4	4.3	4 900	13 500	0.33	3.1	2.1

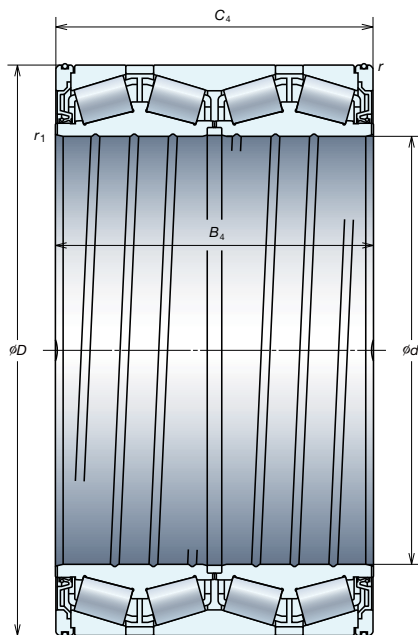

Dynamic Equivalent Load

$$P = X F_r + Y F_a$$

$F_a / F_r \leq e$		$F_a / F_r > e$	
X	Y	X	Y
1	Y ₃	0,67	Y ₂

Static Equivalent Load

$$P_0 = F_r + Y_0 F_a$$

Where $Y_0 = Y_3$

The values of e, Y₂ and Y₃ are given in the table.

Remarks

(*) Bearings marked * are inch designs.

Water-TF™ Bearings are a special purpose bearing series in the same design as the standard Extra-Capacity Sealed-Clean Four-Row Tapered Roller Bearings. Other bearings are available. Please contact NSK for additional information.

Dimensions of Bearings for Rolling Mills

Extra-Capacity Sealed-Clean™ Four-Row Tapered Roller Bearings – KVS Series

Bearing Numbers	Boundary Dimensions (mm/inch)						Basic Load Ratings (kN)		Constant e	Axial Load Factors	
	d	D	B_4	C_4	r (min)	r_1 (min)	C_r	C_{or}		Y_2	Y_3
STF170KVS2401Eg	170	240	175	175	2.5	2.5	1 020	2 010	0.32	3.2	2.1
*STF215KVS2851Eg	215.900 (8.5000)	288.925 (11.3750)	177.800 (7.0000)	177.800 (7.0000)	3.3	0.8	1 070	2 350	0.49	2.1	1.4
*STF216KVS3351Eg	216.103 (8.5080)	330.2 (13.0000)	263.525 (10.3750)	263.525 (10.3750)	3.3	1.5	2 290	4 550	0.46	2.2	1.5
STF220KVS3301Eg	220	330	260	260	3.0	4.0	2 330	4 800	0.40	2.5	1.7
*STF234KVS3251Eg	234.950 (9.2500)	327.025 (12.8750)	196.850 (7.7500)	196.850 (7.7500)	3.3	1.5	1 550	3 200	0.46	2.2	1.5
*STF244KVS3251Eg	244.475 (9.6250)	327.025 (12.8750)	193.680 (7.6250)	193.680 (7.6250)	3.0	1.5	1 370	3 050	0.40	2.5	1.7
STF245KVS3402Eg	245	345	310	310	3.0	2.0	2 700	6 650	0.40	2.5	1.7
*STF254KVS3552	254.000 (10.0000)	358.775 (14.1250)	269.875 (10.6250)	269.875 (10.6250)	3.3	1.5	2 420	5 500	0.40	2.5	1.7
STF260KVS3601Eg	260	365	340	340	4.0	2.7	2 960	7 350	0.40	2.5	1.7
STF260KVS3651Eg	260	365	340	340	4.0	2.5	2 960	7 350	0.40	2.5	1.7
*STF260KVS4251Eg	260.350 (10.2500)	422.275 (16.6250)	314.325 (12.3750)	314.325 (12.3750)	3.3	6.4	3 600	7 050	0.33	3.0	2.0
*STF266KVS3551Eg	266.700 (10.5000)	355.600 (14.0000)	230.188 (9.0625)	230.188 (9.0625)	3.3	1.5	1 960	4 600	0.35	2.9	1.9
*STF76KVS3952Eg	276.225 (10.8750)	393.700 (15.5000)	269.875 (10.6251)	269.875 (10.6251)	3.3	1.5	2 720	6 100	0.45	2.2	1.5
*STF279KVS3952Eg	279.400 (11.0000)	393.700 (15.5000)	269.875 (10.6251)	269.875 (10.6251)	6.4	1.5	2 720	6 100	0.45	2.2	1.5
*STF279KVS3954Eg	279.4	393.7	320	320	6.4	1.5	3 100	7 350	0.40	2.5	1.7
STF290KVS4001Eg	290	400	346	346	4.0	3.0	3 250	8 400	0.40	2.5	1.7
*STF304KVS4351Eg	304.648 (11.9940)	438.048 (17.2460)	280.990 (11.6260)	280.990 (11.6260)	3.3	3.3	3 100	6 750	0.45	2.2	1.5
*STF304KVS4155Eg	304.800 (12.0000)	419.100 (16.5000)	269.875 (10.6250)	269.875 (10.6250)	3.0	1.5	2 850	6 550	0.33	3.0	2.0
*STF304KVS4152Eg	304.902 (12.0040)	412.648 (12.6250)	266.700 (10.50000)	266.700 (10.50000)	3.0	1.5	2 760	6 500	0.33	3.0	2.0
STF310KVS4301Eg	310	430	310	310	3.3	3.0	3 350	8 200	0.46	2.2	1.5
STF310KVS4302Eg	310	430	350	350	3.3	2.7	3 700	9 550	0.46	2.2	1.5
*STF317KVS4251Eg	317.500 (12.5000)	422.275 (16.6250)	269.875 (10.6250)	269.875 (10.6250)	3.3	1.5	2 740	6 750	0.34	3.0	2.0

Remarks: Other bearings are available. Please contact NSK for additional information.



Bearing Numbers	Boundary Dimensions (mm/inch)						Basic Load Ratings (kN)		Constant e	Axial Load Factors	
	d	D	B ₄	C ₄	r (min)	r ₁ (min)	C _r	C _{0r}		Y ₂	Y ₃
*STF343KVS4551Eg	340.052 (13.5060)	457.098 (17.9960)	254.000 (10.0000)	254.000 (10.0000)	3.3	1.5	2 830	6 700	0.45	2.2	1.5
*STF355KVS4551Eg	355.600 (14.0000)	457.200 (18.0000)	252.412 (9.9375)	252.412 (9.9375)	3.3	1.5	2 650	6 750	0.32	3.2	2.1
*STF406KVS5451Eg	406.400 (16.0000)	546.100 (21.5000)	288.925 (11.3750)	288.925 (11.3750)	6.4	1.5	3 950	9 450	0.48	2.1	1.4
STF450KVS5901Eg	450	595	368	368	5.0	4.0	5 550	15 000	0.33	3.0	2.0
*STF457KVS5951Eg	457.200 (18.0000)	596.900 (23.5000)	276.225 (10.8750)	276.225 (10.8750)	3.3	1.5	4 000	9 850	0.47	2.2	1.4
STF482KVS6151Eg	482.600 (19.0000)	615.950 (24.2500)	330.200 (13.0000)	330.200 (13.0000)	6.4	4.3	4 900	13 500	0.33	3.1	2.1

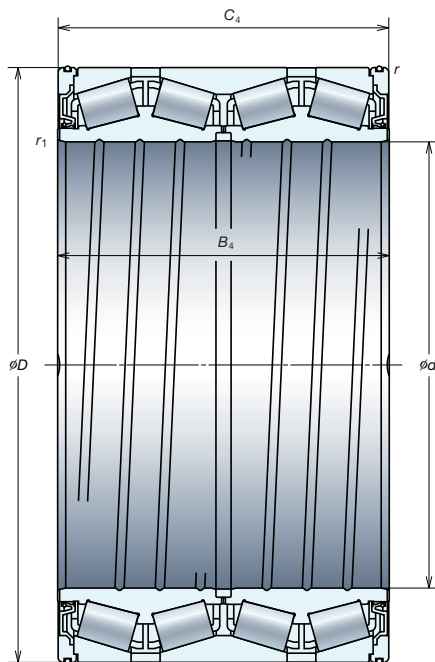

Dynamic Equivalent Load

$$P = X F_r + Y F_a$$

$F_a / F_r \leq e$		$F_a / F_r > e$	
X	Y	X	Y
1	Y ₃	0,67	Y ₂

Static Equivalent Load

$$P_0 = F_r + Y_0 F_a$$

$$\text{Where } Y_0 = Y_3$$

The values of e, Y₂ and Y₃ are given in the table.

- Remarks**
1. Extra-Capacity Sealed-Clean Four-Row Tapered Roller Bearings are made of NSK Super-TF material as the standard specification
 2. Bearings marked * are inch design and numerical values in parentheses under Boundary Dimensions are in inches..

Dimensions of Bearings for Rolling Mills

Super-TF™ Four-Row Cylindrical Roller Bearings – STF-RV Series

Bearing Numbers	Boundary Dimensions (mm)					Basic Load Ratings (kN)	
	d	D	B	C ₂	F _w	C _r	C _{0r}
STF380RV5414g	380	540	300	300	421	4 450	9 700
STF380RV5411g	380	540	400	400	422	6 000	14 400
STF400RV5611g	400	560	410	410	445	6 550	16 500
STF420RV6012g	420	600	440	440	465	7 300	17 200
STF430RV5911g	430	591	420	420	476	6 350	16 100
STF440RV6215g	430	620	450	450	487	8 100	19 700
STF460RV6513g	440	650	470	470	509	8 600	21 200
STF470RV6611g	460	660	470	470	519	8 450	20 800
STF480RV6814g	470	680	420	420	528	8 350	19 000
STF480RV6815g	480	680	500	500	532	9 400	23 500
STF500RV6713g	480	670	450	450	540	7 750	20 000
STF500RV7111g	500	710	480	480	558	8 500	21 200
STF500RV7214g	500	720	530	530	568	10 100	25 900
STF510RV6811g	510	680	500	500	560	8 950	25 700
STF520RV7311g	520	735	535	535	574.5	10 800	27 500
STF530RV7811g	530	780	570	570	601	11 800	29 200
STF550RV7413g	550	740	510	510	600	10 100	27 600
STF560RV8011g	560	800	600	600	620	12 400	31 500
STF560RV8211g	560	820	600	600	625	14 100	34 000
STF570RV8113g	570	815	594	594	628	13 200	32 000
STF600RV8212g	600	820	575	575	660	12 900	35 500
STF600RV8511g	600	850	600	600	664	14 600	37 500
STF600RV8511g	600	870	640	640	682	15 700	40 000
STF600RV8741g	600	870	640	640	669	15 700	40 000
STF628RV9211g	628	922	600	600	702	15 600	37 000
STF634RV9011g	634.5	901.87	674	674	705	17 000	44 500
STF650RV9212g	650	920	670	670	723	16 200	44 000

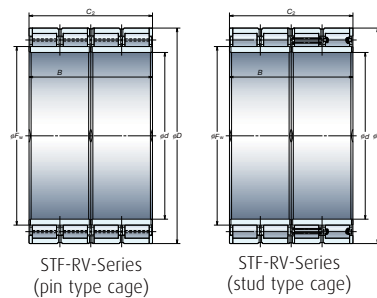

Bearing Numbers	Boundary Dimensions (mm)					Basic Load Ratings (kN)	
	d	D	B ₄	C ₂	F _w	C _r	C _{0r}
STF660RV9311g	660	930	660	660	728	17 000	44 000
STF690RV9611g	690	960	670	670	760	17 400	47 000
STF690RV9813g	690	980	750	750	766	19 200	53 000
STF700RV9313g	700	930	620	620	763	14 800	43 000
STF700RV9812g	700	980	700	700	766	18 800	49 000
STF725RV1012g	725	1 000	700	700	790	19 000	51 500
STF730RV1011g	730	1 030	750	750	809	20 700	56 500
STF750RV1013g	750	1 000	670	670	813	17 500	50 000
STF760RV1012g	760	1 030	750	750	828	20 800	60 000
STF761RV1012g	761.425	1 079.6	787.4	787.4	846	23 900	65 500
STF770RV1011g	770	1 075	770	770	847	23 100	63 500
STF800RV1013g	800	1 080	700	700	787	19 100	56 000
STF800RV1012g	800	1 100	750	750	880	19 300	57 000
STF820RV1119g	820	1 130	745	720	892	20 100	59 000
STF820RV11112g	820	1 130	650	650	891	20 300	53 000
STF820RV11110g	820	1 130	800	800	903	22 900	66 500
STF840RV1111g	840	1 160	840	840	920	24 900	71 500
STF850RV1115g	850	1 150	840	840	928	25 600	77 500
STF850RV1111g	850	1 180	850	850	940	24 700	72 500
STF900RV1216g	900	1 220	800	800	981	25 900	74 500
STF900RV1212g	900	1 220	840	840	898	26 800	80 000
STF900RV1217g	900	1 280	930	930	1 000	33 000	93 000
STF950RV1314g	950	1 330	950	950	1 053	33 500	97 000
STF800RV1014g	800	1 080	700	700	878	19 200	55 000
STF1270RV1612g	1 270	10602	850	850	1 350	32 000	103 000
STF1300RV1612g	1 300	1 655	890	890	1 391	34 000	110 500
STF1348RV1711g	1 348.95	1 745	1 010	1 000	1 466	42 500	134 000

Remarks: The specification of oil mist fitting and O-rings on outer rings are available when requested.
Other bearings are available. Please contact NSK for additional information.

European NSK Sales Offices

France

NSK France S.A.S.
Quartier de l'Europe
2, Rue Georges Guynemer
78283 Guyancourt Cedex
Tel. +33 (0) 1 30573939
Fax +33 (0) 1 30570001
info-fr@nsk.com

Norway

Nordic Sales Office
NSK Europe Norwegian Branch NUF
Østre Kullerød 5
N-3241 Sandefjord
Tel. +47 33 293160
Fax +47 33 429002
info-de@nsk.com

Sweden

NSK Sweden Office
Karolinen Företagscenter
Växnäsgatan 10
SE-65340 Karlstad
Tel. +46 5410 3545
Fax +46 5410 3544
info-de@nsk.com

Germany

NSK Deutschland GmbH
Harkortstraße 15
40880 Ratingen
Tel. +49 (0) 2102 4810
Fax +49 (0) 2102 4812290
info-de@nsk.com

Poland & CEE

NSK Polska Sp. z o.o.
Warsaw Branch
Ul. Migdałowa 4/73
02-796 Warszawa
Tel. +48 22 6451525
Fax +48 22 6451529
info-pl@nsk.com

Turkey

NSK Rulmanlari Orta Doğu Tic. Ltd. Şti
19 Mayıs Mah. Atatürk Cad.
Ulya Engin İş Merkezi No: 68 Kat. 6
P.K.: 34734 - Kozyatağı - İstanbul
Tel. +90 216 3550398
Fax +90 216 3550399
turkey@nsk.com

Italy

NSK Italia S.p.A.
Via Garibaldi 215 - C.P. 103
20024 Garbagnate
Milanese (MI)
Tel. +39 02 995191
Fax +39 02 99025778
info-it@nsk.com

Spain

NSK Spain, S.A.
C/ Tarragona, 161 Cuerpo Bajo
2ª Planta, 08014 Barcelona
Tel. +34 93 2892763
Fax +34 93 4335776
info-es@nsk.com

UK

NSK UK Ltd.
Northern Road, Newark
Nottinghamshire NG24 2JF
Tel. +44 (0) 1636 605123
Fax +44 (0) 1636 602775
info-uk@nsk.com

Please also visit our website: www.nskeurope.com
Global NSK: www.nsk.com

