



SOPORTES AUTOALINEANTES
SELF-ALIGNING BEARING UNITS



CATÁLOGO TÉCNICO GENERAL
GENERAL TECHNICAL CATALOGUE



1.07.12

Soportes Autoalineantes *Self-aligning bearing units*



**DISPONIBLES SOPORTES PARA ALTAS TEMPERATURAS
HIGH TEMPERATURES BEARING UNITS AVAILABLE**

Soportes acero inox *Stainless steel bearing units*



Soportes de plástico *Plastic bearing units*



Política ambiental

El presente **Catálogo Técnico ISB**® ha sido realizado con **material ecológico certificado FSC**. El proceso productivo del papel se lleva a cabo respetando las normativas vigentes. **DS/EN ISO 14001** e **ISO 9001:2008**. Las tintas para la impresión son de base vegetal. Por favor continúe Usted también con su compromiso por la protección del medio ambiente.

Environmental policy

This **ISB**® **Technical Catalogue** has been produced with **100% ecological material certified FSC**. Manufacturing process follows the regulations in force: **DS/EN ISO 14001** and **ISO 9001:2008**. Inks used are vegetable based. Please continue your actions in order to protect the environment and recycle properly.

PROGRAMA GENERAL DE VENTAS
GENERAL SALES PROGRAM



RODAMIENTOS Y COMPONENTES *
BEARINGS AND COMPONENTS *



SOPORTES AUTOALINEANTES *
SELF-ALIGNING BEARING UNITS *



RÓTULAS - CABEZAS DE ARTICULACIÓN - HORQUILLAS *
SPHERICAL PLAIN BEARINGS - ROD ENDS - CLEVISES *

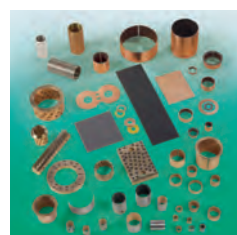

CASQUILLOS*
BUSHES *



CORONAS GIRATORIAS *
SLEWING BEARINGS *

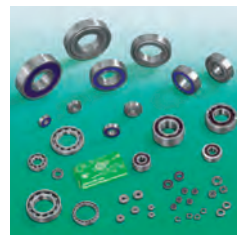

ELECTRICAL MOTORS STANDARD

RODAMIENTOS PARA APLICACIONES "BAJA RUMOROSIDAD" *
BEARINGS FOR "LOW NOISE" APPLICATIONS *



RODAMIENTOS DE AGUJAS *
NEEDLE BEARINGS *



COMPONENTES PARA SISTEMAS LINEALES*
COMPONENTS FOR LINEAR MOTION *

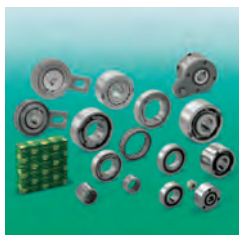

RUEDAS LIBRES *
FREE WHEELS *

Disponibile un stock ampio y completo de rodamientos con entrega inmediata.
Wide and complete assortment of bearings with prompt delivery



RODAMIENTOS SKF - FAG
SKF - FAG BEARINGS

* Para más información le rogamos solicite el catálogo técnico disponible también on-line: www.italcuscineti.it

* For further information, please ask for technical catalogue, also available on line: www.italcuscineti.it



CATÁLOGO TÉCNICO GENERAL
GENERAL TECHNICAL CATALOGUE

Distribuidor / *Distributor*

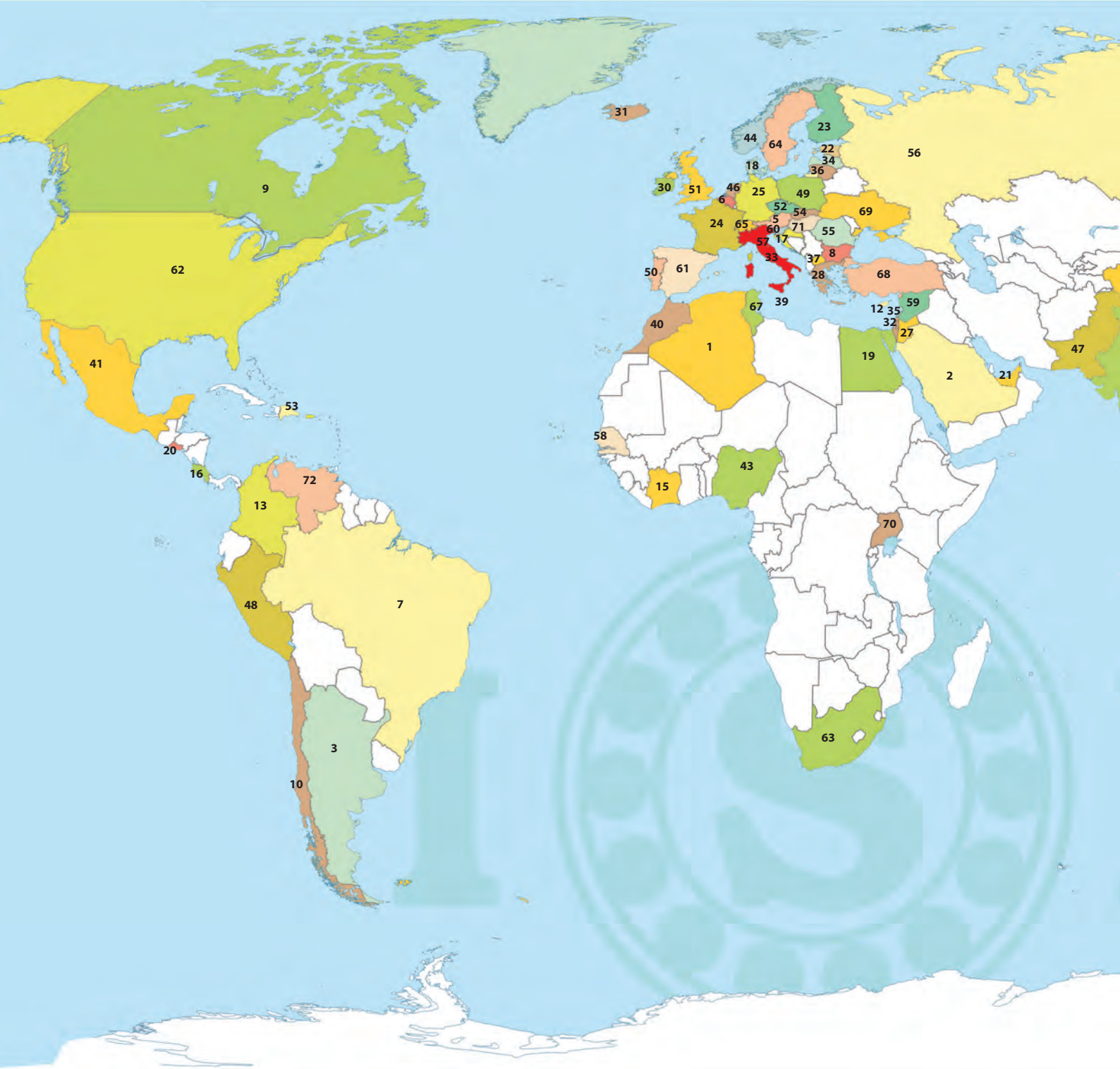

***hora legal (período de marzo a octubre en Italia)**

**summer time (from March to October in Italy)*

hora solar (-1)

standard time (-1)

para las capitales con el horario indicado en rojo no existe una hora legal

time is indicated in red for capitals with no daylight saving time (DST)

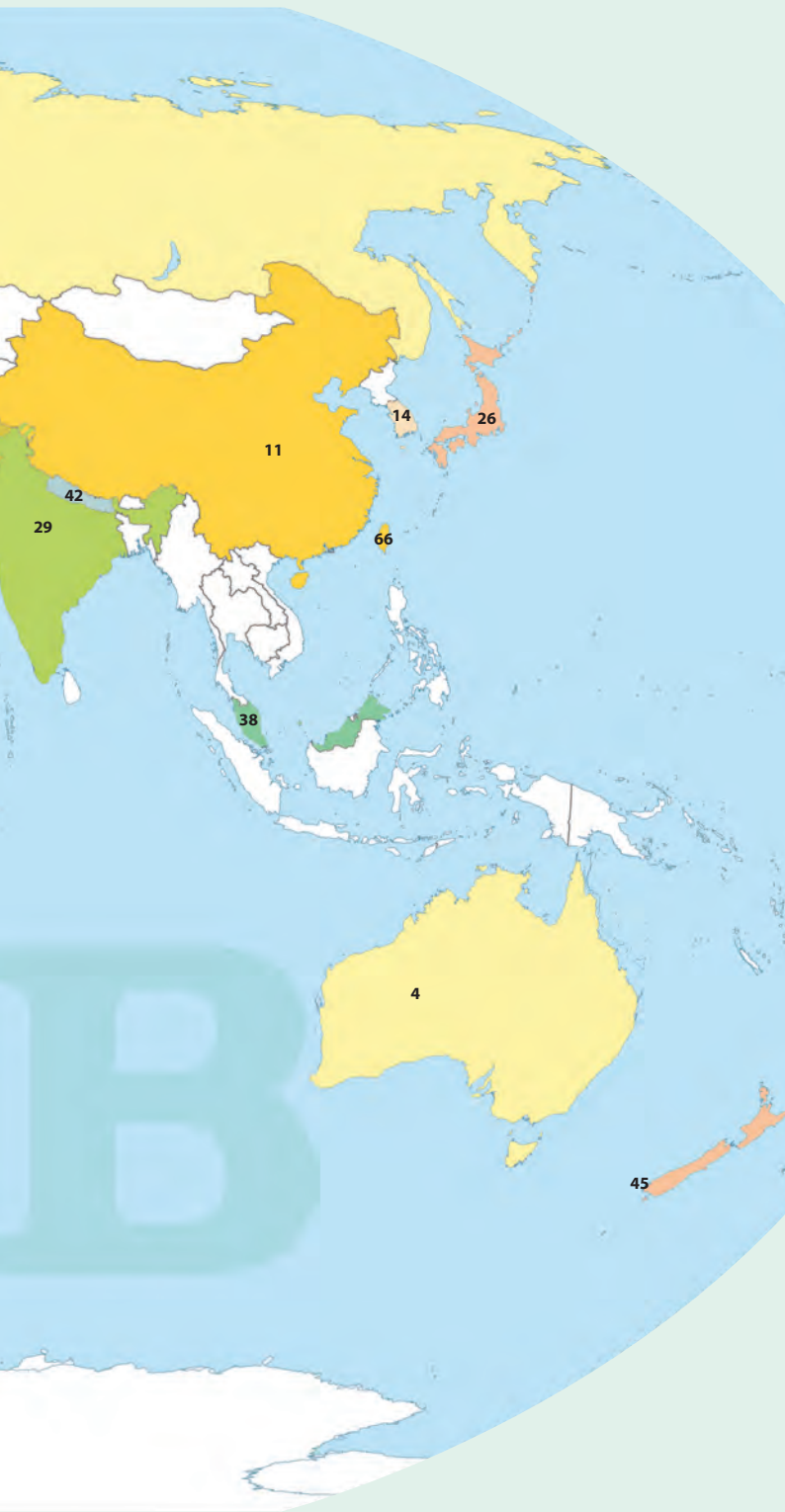

Bandera	País (Ciudad) - Hora	País
	1 ARGELIA (Argel - 11:00)	ALGERIA
	2 ARABIA SAUDITA (Riyadh - 13:00)	SAUDI ARABIA
	3 ARGENTINA (Buenos Aires - 07:00)	ARGENTINA
	4 AUSTRALIA (Canberra - 20:00)	AUSTRALIA
	5 AUSTRIA (Viena - 12:00)	AUSTRIA
	6 BÉLGICA (Bruselas - 12:00)	BELGIUM
	7 BRASIL (Brasilia - 07:00)	BRAZIL
	8 BULGARIA (Sofia - 13:00)	BULGARIA
	9 CANADÁ (Ottawa - 06:00)	CANADA
	10 CHILE (Santiago - 06:00)	CHILE
	11 CHINA (Pekín - 18:00)	CHINA
	12 CHIPRE (Nicosia - 13:00)	CYPRUS
	13 COLOMBIA (Bogotá - 05:00)	COLOMBIA
	14 COREA DEL SUR (Seúl - 19:00)	SOUTH KOREA
	15 COSTA DE MARFIL (Abidjan - 10:00)	IVORY COAST
	16 COSTA RICA (San José - 04:00)	COSTA RICA
	17 CROACIA (Zagreb - 12:00)	CROATIA
	18 DINAMARCA (Copenhague - 12:00)	DENMARK
	19 EGIPTO (El Cairo - 13:00)	EGYPT
	20 EL SALVADOR (San Salvador - 04:00)	EL SALVADOR
	21 EMIRADOS ÁRABES UNIDOS (Abu Dhabi - 14:00)	UNITED ARAB EMIRATES
	22 ESTONIA (Tallinn - 13:00)	ESTONIA
	23 FINLANDIA (Helsinki - 13:00)	FINLAND
	24 FRANCIA (París - 12:00)	FRANCE
	25 ALEMANIA (Berlín - 12:00)	GERMANY
	26 JAPÓN (Tokio - 19:00)	JAPAN
	27 JORDANIA (Amman - 13:00)	JORDAN
	28 GRECIA (Atenas - 13:00)	GREECE
	29 INDIA (Nueva Delhi - 15:30)	INDIA
	30 IRLANDA (Dublín - 11:00)	IRELAND
	31 ISLANDIA (Reykjavik - 10:00)	ICELAND
	32 ISRAEL (Jerusalén - 13:00)	ISRAEL
	33 ITALIA (Roma - 12:00)*	ITALY
	34 LETONIA (Riga - 13:00)	LATVIA
	35 LIBANO (Beirut - 13:00)	LEBANON
	36 LITUANIA (Vilnius - 13:00)	LITHUANIA
	37 MACEDONIA (Skopie - 12:00)	MACEDONIA
	38 MALASIA (Kuala Lumpur - 18:00)	MALAYSIA
	39 MALTA (Valletta - 12:00)	MALTA
	40 MARRUECOS (Rabat - 10:00)	MOROCCO
	41 MÉXICO (Ciudad de México - 06:00)	MEXICO
	42 NEPAL (Kathmandú - 15:45)	NEPAL
	43 NIGERIA (Abuja - 11:00)	NIGERIA
	44 NORUEGA (Oslo - 12:00)	NORWAY
	45 NUEVA ZELANDIA (Wellington - 22:00)	NEW ZEALAND
	46 HOLANDA (Ámsterdam - 12:00)	NETHERLANDS
	47 PAQUISTÁN (Islamabad - 16:00)	PAKISTAN
	48 PERÚ (Lima - 05:00)	PERU
	49 POLONIA (Varsovia - 12:00)	POLAND
	50 PORTUGAL (Lisboa - 11:00)	PORTUGAL
	51 REINO UNIDO (Londres - 11:00)	UNITED KINGDOM
	52 REPUB. CHECA (Praga - 12:00)	CZECH REPUBLIC
	53 REPUB. DOMINICANA (Santo Domingo - 06:00)	DOMINICAN REPUBLIC
	54 REPUB. ESLOVACA (Bratislava - 12:00)	SLOVAKIAN REPUBLIC
	55 RUMANÍA (Bucarest - 13:00)	RUMANIA
	56 RUSIA (Moscú - 14:00)	RUSSIA
	57 SAN MARINO (San Marino - 12:00)	SAN MARINO
	58 SENEGAL (Dakar - 10:00)	SENEGAL
	59 SIRIA (Damasco - 13:00)	SYRIA
	60 ESLOVENIA (Liubliana - 12:00)	SLOVENIA
	61 ESPAÑA (Madrid - 12:00)	SPAIN
	62 ESTADOS UNIDOS DE AMÉRICA (Washington - 06:00)	UNITED STATES OF AMERICA
	63 SUDÁFRICA (Pretoria - 12:00)	SOUTH AFRICA
	64 SUECIA (Estocolmo - 12:00)	SWEDEN
	65 SUIZA (Berna - 12:00)	SWITZERLAND
	66 TAIWAN (Taipei - 18:00)	TAIWAN
	67 TUNISIA (Túnez - 11:00)	TUNISIA
	68 TURQUÍA (Ankara - 13:00)	TURKEY
	69 UCRAINA (Kiev - 13:00)	UKRAINE
	70 UGANDA (Kampala - 14:00)	REPUBLIC OF UGANDA
	71 HUNGRÍA (Budapest - 12:00)	HUNGARY
	72 VENEZUELA (Caracas - 06:00)	VENEZUELA



PRODUCCIÓN PRODUCTION

Todos los productos **ISB®** son fabricados exclusivamente por empresas que cuentan con Sistema de Calidad certificado según las normas UNE EN ISO 9001:2008.

All **ISB®** products are manufactured exclusively by companies with UNI EN ISO 9001:2008 certified Quality System.



... Laboratorios externos especializados y dotados de modernos instrumentos de medición y control realizan una serie de comprobaciones adicionales. Laboratorio Control Calidad.

... an additional series of tests are conducted by specialised third party Laboratories using the latest instruments. Quality Control Laboratory.

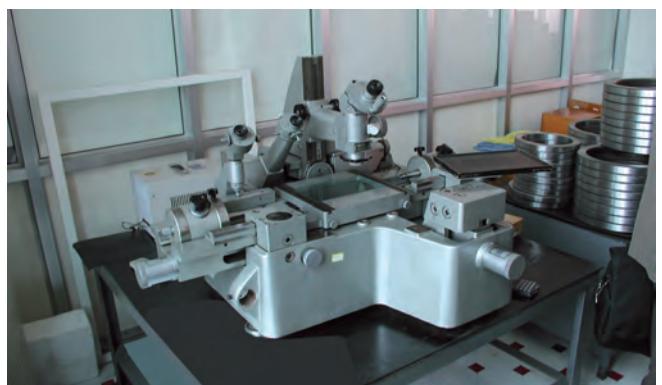
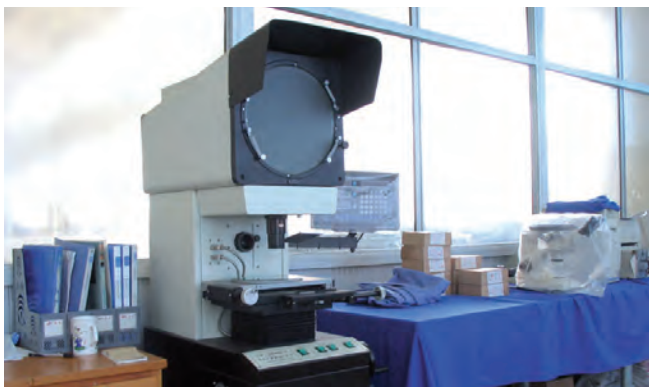

... centro de control de calidad en nuestra sede en ITALIA.
... un staff de Ingenieros técnicos de la Calidad, a su servicio.

... a quality control centre is located in our headquarters in ITALY.
... our staff of technical engineers at your service, for Quality.



ISIR N° 0015
Rapporto di controllo di prima campionatura
Initial Sample Inspection Report

DENOMINAZIONE Part name:
Supporto UFL 005

CODICE ARTICOLO Part number:
31095120

CODICE FORNITORE Supplier code:
WJBXXITA04-S

QTA' CONSEGNERATA Delivered quantity:
10

QTA' CONTROLLATA Inspected quantity:
10

ISPEZIONATO DA Inspected by:
Quality Control

DATA Date:
13/09/2010

DATA Date:
09/09/2010

Caratteristiche controllate Inspected characteristics

Posizione Key	Dimensione nominale Specifiche materiali Nominal dimension Material specification	Unità di misura Unit of measure	Tolleranze Tolerances	Risultati della misurazione Measurement results				
				Articolo 1 Piece	Articolo 2 Piece	Articolo 3 Piece	Articolo 4 Piece	Articolo 5 Piece
1	Bore Ø 25 (d)	mm	0 / +0,021	25,010	25,009	25,012	25,008	25,009
2	Quote 22,5 (a)	mm	0 / -0,120	22,410	22,420	22,415	22,430	22,417
3	Quote 95 (a)	mm	-	94,85	94,95	94,89	94,88	94,89
4	Quote 75 (e)	mm	-	75,01	75,03	74,98	74,99	75,00
5	Holes Ø 10	mm	-	10,10	10,12	10,09	10,12	10,11
6	Quote 16 (l)	mm	-	15,95	15,98	15,96	16,02	16,02
7	Quote 24,5 (z)	mm	-	24,45	24,40	24,50	24,4	24,4
8	Quote 60 (b)	mm	-	59,48	59,52	59,60	59,45	59,45
9	Hardness (ring)	HRC	61 ± 2	60,8	60,9	61,5	61,1	61,1
10	Hardness (grain zone annealing)	HRC	53 ± 2	53,5	53,8	54,1	53,8	53,8
11								
12								
13								
14								
15								
16								
Peso del campione Sample weight:			kg	0,218				

Da compilare a cura di To be filled by ISB

Deviazione Deviation n.	Decisioni Decisions	Approvato Approve					Respinto Fail					Deroga Deviate
		Articolo 1 Piece	Articolo 2 Piece	Articolo 3 Piece	Articolo 4 Piece	Articolo 5 Piece	Articolo 1 Piece	Articolo 2 Piece	Articolo 3 Piece	Articolo 4 Piece	Articolo 5 Piece	
1. Deviazione Deviation n.	Dimensioni Dimensions	X	X	X	X	X						
2.	Laboratorio Laboratory											
3.	Funzionalità Functionality											
4.	Aspetto Appearance	X	X	X	X	X						

ISIR N° 0015
Rapporto di controllo di prima campionatura
Initial Sample Inspection Report

DENOMINAZIONE Part name:
Supporto UFL 005

CODICE ARTICOLO Part number:
31095120

CODICE FORNITORE Supplier code:
WJBXXITA04-S

QTA' CONSEGNERATA Delivered quantity:
10

QTA' CONTROLLATA Inspected quantity:
10

ISPEZIONATO DA Inspected by:
Quality Control

DATA Date:
13/09/2010

DATA Date:
09/09/2010

Caratteristiche controllate Inspected characteristics

Posizione Key	Dimensione nominale Specifiche materiali Nominal dimension Material specification	Unità di misura Unit of measure	Tolleranze Tolerances	Risultati della misurazione Measurement results					Esito Result	Verifica Control
				Articolo 6 Piece	Articolo 7 Piece	Articolo 8 Piece	Articolo 9 Piece	Articolo 10 Piece		
1	Bore Ø 25 (d)	mm	0 / +0,021	25,005	25,005	25,005	25,007	25,007	X	OK
2	Quote 22,5 (B)	mm	0 / -0,120	22,405	22,410	22,410	22,400	22,420	X	OK
3	Quote 95 (a)	mm	-	94,99	94,97	94,92	94,94	94,99	X	OK
4	Quote 75 (e)	mm	-	75,05	75,08	75,01	75,02	74,97	X	OK
5	Holes Ø 10	mm	-	10,13	10,05	10,06	10,06	10,04	X	OK
6	Quote 16 (l)	mm	-	16,01	16,04	16,06	16,06	16,03	X	OK
7	Quote 24,5 (z)	mm	-	24,45	24,40	24,50	24,4	24,4	X	OK
8	Quote 60 (b)	mm	-	59,52	59,60	59,49	59,62	59,44	X	OK
9	Hardness (ring)	HRC	61 ± 2	61,4	61,6	61,1	60,8	61,5	X	OK
10	Hardness (grain zone annealing)	HRC	53 ± 2	52,5	52,1	51,6	53,0	53,2	X	OK
11										
12										
13										
14										
15										
16										
Peso del campione Sample weight:			kg	0,218						

Da compilare a cura di To be filled by ISB

Deviazione Deviation n.	Decisioni Decisions	Approvato Approve					Respinto Fail					Deroga Deviate
		Articolo 1 Piece	Articolo 2 Piece	Articolo 3 Piece	Articolo 4 Piece	Articolo 5 Piece	Articolo 1 Piece	Articolo 2 Piece	Articolo 3 Piece	Articolo 4 Piece	Articolo 5 Piece	
1.	Dimensioni Dimensions	X	X	X	X	X						
2.	Laboratorio Laboratory											
3.	Funzionalità Functionality											
4.	Aspetto Appearance	X	X	X	X	X						

Commenti Notes
All samples comply to the requirements.
Final acceptance is given.

DATA Date: 13/09/2010
Firma Signature: Quality Control

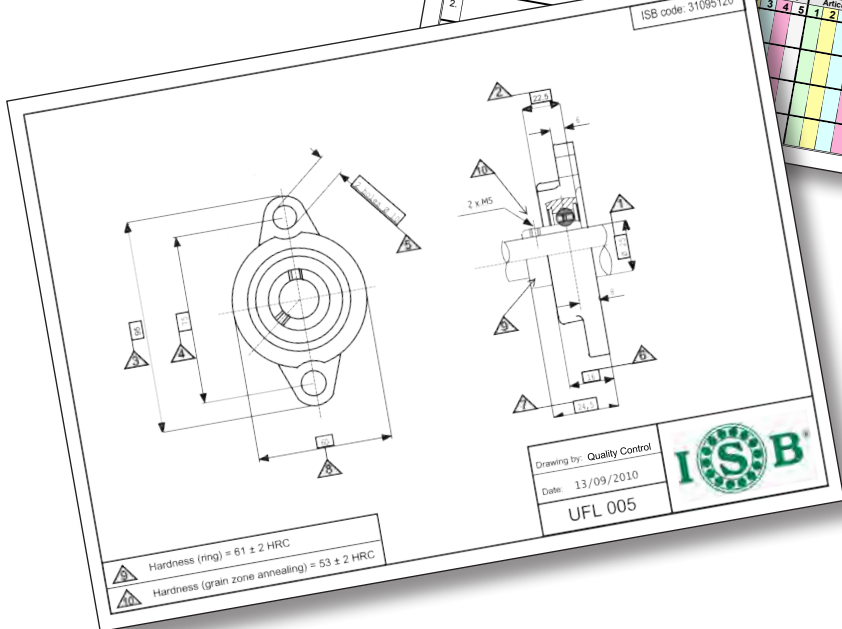

AGRICULTURA
CASA
INDUSTRIA
MAQUINARIA
TIEMPO LIBRE
OFICINAS
VEHÍCULOS

AGRICULTURE
HOME
INDUSTRY
MACHINERIES
FREE TIME
OFFICE
VEHICLES

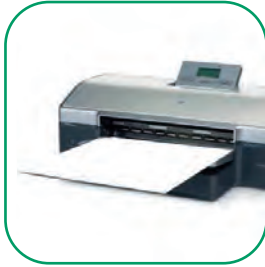

Las numerosas líneas de rodamientos y componentes **ISB®** permiten satisfacer las exigencias en los más diversos sectores de aplicación. La amplia gama y la calidad de los productos permiten garantizar aplicaciones también en condiciones de empleo exigentes. Los rodamientos y componentes **ISB®** abarcan una producción articulada que incluye todas las tipologías y es adecuada por lo tanto para satisfacer las más variadas exigencias aplicativas.

*The diverse product lines of **ISB®** bearings and components make it possible to satisfy the needs of a wide variety of fields of application. The wide range and quality of products is also a guarantee for heavy duty applications. **ISB®** bearings and components are available in versions across-the-board and can meet the requirements of a wide variety of demanding applications.*



RODAMIENTOS
BEARINGS

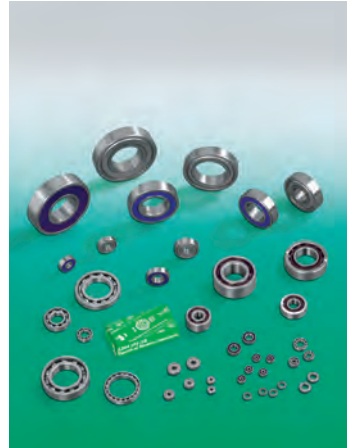

RODAMIENTOS PARA APLICACIONES "BAJA RUMOROSIDAD"
BEARINGS FOR "LOW NOISE" APPLICATIONS



SOPORTES AUTOALINEANTES
SELF-ALIGNING BEARING UNITS



RÓTULAS CABEZAS DE ARTICULACIÓN - HORQUILLAS
SPHERICAL PLAIN BEARINGS
ROD ENDS - CLEVISSES



CASQUILLOS
BUSHES



RODAMIENTOS DE GRANDES DIMENSIONES
LARGE BEARINGS



CORONAS DE GIRO
SLEWING BEARINGS



RODAMIENTOS DE BOLAS DE MATERIALES POLIMÉRICOS
POLYMERIC BALL BEARINGS



RODAMIENTOS BONDERIZADOS PARA ALTAS TEMPERATURAS
BONDERIZED BEARINGS FOR HIGH TEMPERATURES



BOLAS TRANSPORTADORAS BOLAS DE PRECISIÓN RODILLOS Y AGUJAS DE PRECISIÓN
BALL TRANSFER UNITS
PRECISION BALLS
PRECISION ROLLERS AND NEEDLES



OBTURACIONES METÁLICAS PARA RODAMIENTOS
METALLIC SEALS FOR BEARINGS



PRODUCTOS DE ACERO INOXIDABLE
STAINLESS STEEL PRODUCTS

La gama de productos ISB® está en continuo desarrollo y será en breve ampliada con la incorporación de nuevas referencias.
The ISB® range is continuously in evolution and shortly will be widened by the addition of new items.

	Título Title	Página Page
1.	Estructura soportes - Structure of bearing units	1
1.1	ISB® marca sinónimo de calidad - ISB® is a trademark which identifies quality	2
2.	Características técnicas constructivas - Technical constructive characteristics	2
2.1	Material de los rodamientos - Bearing material	3
2.2	Material de las jaulas y de los remaches - Cages and rivets material	4
2.3	Material del cuerpo - Housing material	4
2.4	Materiales de los otros componentes - Other components material	5
2.5	Obturaciones y protecciones - Seals and covers	6
3.	Tolerancias y símbolos - Symbols and tolerances	6
3.1	Tolerancias del diámetro del alojamiento - Tolerance of spherical bore diameter of housings	9
3.2	Tolerancias de los soportes - Bearing units tolerances	10
3.3	Tolerancias de los soportes de brida - Flange bearing units tolerances	11
3.4	Tolerancias de los soportes tensores y de cartucho cilíndrico - Take-up and cylindrical cartridge bearing units tolerances	12
3.5	Tolerancias de los ejes - Shafts tolerances	13
3.6	Precisión dimensional de las fundiciones - Dimensional accuracies of castings	14
3.7	Tolerancias de las fundiciones - Castings tolerances	14
3.8	Carga admisible de los soportes - Allowed load of bearing units	15
3.9	Carga admisible de los soportes en chapa estampada - Allowed load of pressed steel housings	16
3.10	Coefficiente de seguridad - Safety factor	16
3.11	Velocidad máxima (rpm) - Max rpm.	17
4.	Coefficientes de carga y vida útil - Load ratings and life	17
4.1	Coefficiente de carga estática C_0 - Static load ratings C_0	20
4.2	Coefficiente de seguridad estático S_0 - Static load safety factor S_0	20
4.3	Carga radial dinámica y estática equivalente - Equivalent radial dynamic and static load	21
5.	Juego de los rodamientos de bolas - Clearance of ball bearings	21
5.1	Tipo de juego radial - Types of radial clearance	22
6.	Lubricación - Lubrication	24
6.1	Soportes libres de mantenimiento - Maintenance-free bearing units	24
6.2	Soportes reengrasables - Re-greaseable bearing units	25
6.3	Frecuencia de la lubricación - Periodicity of lubrication	25
6.4	Indicaciones para la lubricación - Rules for lubrication	26
6.5	Cantidad de grasa - Grease quantity	27
6.6	Engrasadores - Grease nipple	28
6.7	Tabla de los lubricantes - Tables of lubricants	29
7.	Montaje y desmontaje - Mounting and disassembly	30
7.1	Fijación con pasadores - Setscrews fixing	31
7.2	Fijación con manguito - Taper adapter fixing	32
7.3	Fijación con anillo de exéntrico de fijación - Eccentric collar locking fixing	33
7.4	Movimiento axial debido a la expansión o la contracción - Axial movement due to expansion and shrinkage	34
7.5	Desmontaje del soporte - Disassembly of bearing unit	35
7.6	Sustitución del rodamiento - Bearing replacement	35
8.	Tabla conversión durezas - Conversion table of hardness	36
9.	Tabla de conversión pulgadas/milímetros - Conversion table of inch/millimetres	37
10.	Tabla de intercambiabilidad - Interchangeability table	38
11.	Tipos de soportes y de rodamientos ISB® - ISB® Bearing units and bearings type	40
12.	Índice general de los productos ISB® - ISB® Products general index	41
13.	Soportes para alta temperatura - Bearing units for high temperature	42



Engrasador para lubricación

Grease nipple for lubrication

Doble obturación: chapa de protección más obturación de caucho

Double protection: combination of steel and rubber seal

Agujero de fijación del soporte

Self-aligning bearing units fixing hole

Superficie esférica autoalineable

Self-aligning surface

Pasador suministrable también con manguito o collar excéntrico de fijación

Set screw fixing also available with eccentric collar or tapered adapter sleeve

Corona giratoria de una hilera de bolas

Single row deep groove ball bearing

Soporte de fundición

One-piece cast iron housing

Aro interior templado y rectificado

Hardened ground inner ring

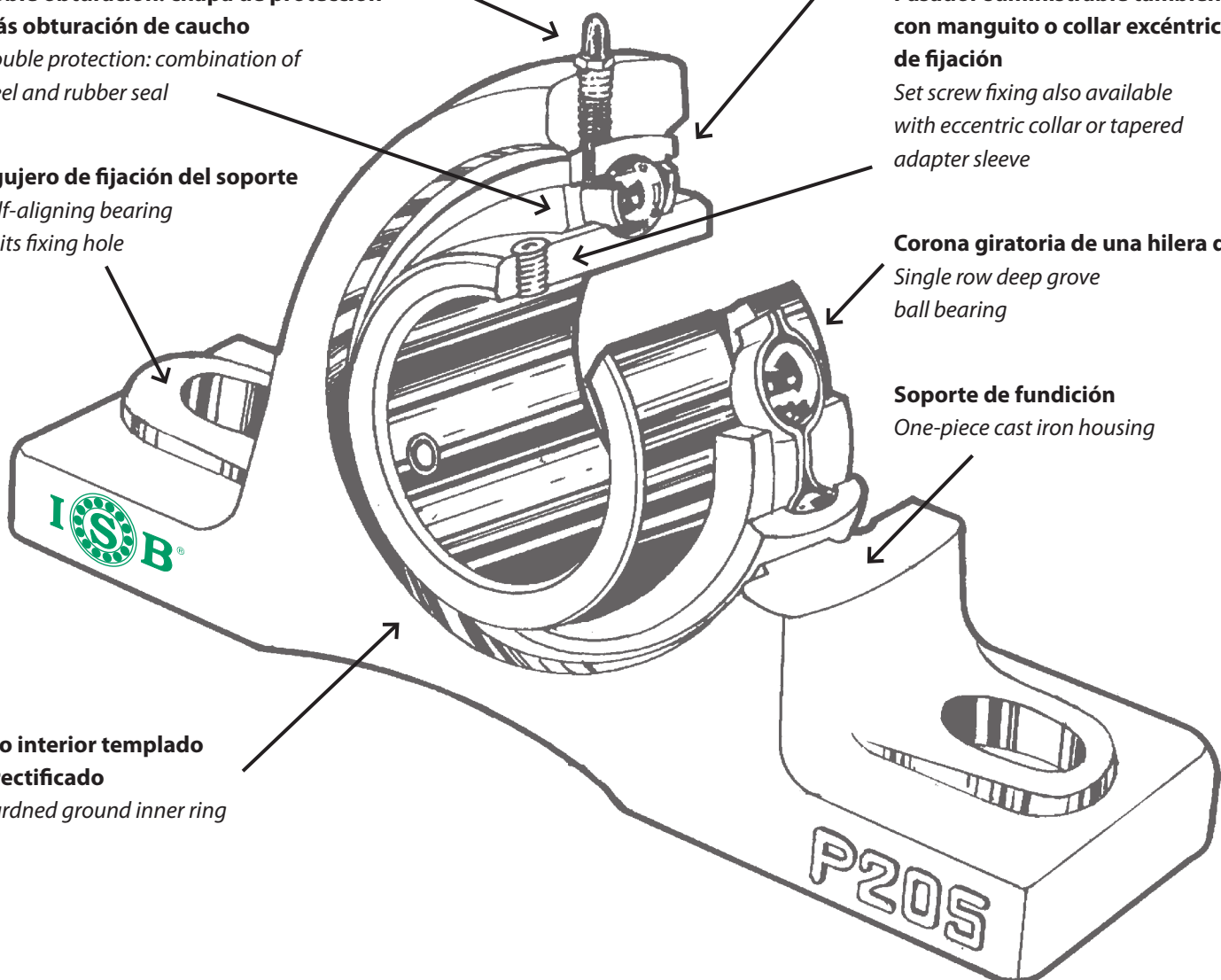

La marca **ISB®**, representa una gama de artículos técnicos cuya producción está a cargo de un grupo de fabricantes que han acumulado décadas de experiencia en el sector. El elevado know-how técnico conjuntamente con equipos de alto nivel permiten garantizar una producción con elevados estándares de calidad, tanto en lo relativo a las fases de producción como también para los productos acabados. Este catálogo técnico ofrece una visión de toda la gama de productos disponibles. Les recordamos además que en caso de aplicaciones especiales podrán Ustedes ponerse en contacto con nuestra Oficina Técnica.

La finalidad principal del catálogo es la de ayudar a los diseñadores de máquinas, suministrándoles las informaciones necesarias para que puedan identificar las mejores aplicaciones y las soluciones posibles para las actividades de su competencia.

La primera parte del catálogo ilustra las características técnicas generales de todos los soportes de fundición y de los rodamientos **ISB®** (características constructivas, tolerancias, coeficientes de carga y vida útil, juego del rodamiento, lubricación, y otras informaciones) y a continuación se indican las tablas de medidas de los productos. En la segunda parte del catálogo se exponen las características y las tablas de medidas de los soportes de la serie pesada y por último en la tercera parte se ilustran los soportes de plástico.

Todas las características técnicas constructivas respetan las normas ISO y DIN, en modo tal de garantizar un producto de elevada calidad, que mantenga las mismas características en el tiempo y que resulte intercambiable con las marcas más prestigiosas a nivel mundial.

*The **ISB®** trademark represents a range of technical articles, the production of which is entrusted to a pool of constructors who, exploit their several decades of experience in the sector. High level technical know-how together with advanced equipment guarantee elevated production standards both in the productive phase as well as the quality control phase on the finished product. This technical catalogue illustrates our range of products; though special applications are possible by contacting our technical office as well.*

The principal objective of this technical catalogue is to help project managers by furnishing them with the necessary information to find the best applications and solutions possible for the activity of their competence.

*The first part of this technical catalogue illustrates the general technical characteristics of all the housings in cast iron and the **ISB®** ball bearings (constructive characteristics, tolerances, load and duration coefficients, clearance of the ball bearing, lubrication and various other general information), followed by tables with the sizes of the products. In the second part of the catalogue the characteristics are illustrated in the tables the sizes of the heavy series housings are listed, after which is the third part which moves to the plastic housings.*

All of the technical characteristics of construction are in accordance with ISO and DIN rules, in order to guarantee an elevated product which maintains the same characteristics over time and is interchangeable with more well known brands on a world wide level.

Los soportes **ISB®** se fabrican en múltiples diseños, con cuerpo exterior de fundición, aleación de aluminio, chapa de acero estampado y plástico. Los soportes se suministran con un rodamiento provisto de un aro exterior esférico que tiene libertad para oscilar en la respectiva pista del soporte, en modo tal de compensar cualquier defecto de alineación y eliminar todo posible esfuerzo entre el eje y el soporte. El rodamiento presente en el asiento del soporte tiene las mismas características constructivas de los rodamientos de la serie 62 o 63, de conformidad con las tablas ISO.

***ISB®** housings are constructed in multiple executions, with external parts in cast iron, bound with aluminium, in moulded steel sheets and in plastic.*

The housing units are supplied complete with ball bearing, provided with external ball rings which can oscillate in the corresponding track hollowed out in the casting, in such a way as to compensate for any defect of alignment, eliminating solicitation between the shaft and the prop. It corresponds to the internal constructive characteristics of the 62 or 63 series according to the ISO tables.

A ambos lados del rodamiento están montadas obturaciones particularmente diseñadas e indicadas para garantizar el sellado perfecto y evitar toda posible filtración de polvo, humedad y fluidos de cualquier tipo. Todos los rodamientos están pre-engrasados y son relubricables, a excepción de las series: CB - RB - SA - SB, que cuentan con una lubricación de por vida.

En el caso de los soportes que deben ser utilizados en condiciones particularmente críticas, como por ejemplo en los ambientes donde operan las empresas agrícolas, siderúrgicas o las fundiciones, los soportes se pueden suministrar con tapas de protección suplementarias. Las tapas podrán ser de fundición gris, chapa de acero o plástico y están diseñadas en modo tal de permitir la eventual sustitución de las obturaciones de caucho con normales anillos de fieltro. Existen también tapas cerradas utilizables en aplicaciones que no cuentan con el eje pasante.

Specially studied and particularly indicated resistance gaskets are located on both sides of the ball bearing, to guarantee perfect resistance, this avoids eventual infiltration from dust, humidity and fluids of various types.

All of the ball bearings are pre-lubricated and can be lubricated repeatedly, except the series: CB - RB - SA - SB, which are lubricated for their lifetime.

Should the housing be used in particularly critical conditions such as the ambient where agricultural companies or iron and steel foundries operate, all of the housings can be supplied with supplementary protective covers.

The covers can be constructed in grey cast iron or in steel sheets or in plastic and are constructed in such a way as to guarantee even eventual substitution of rubber seals with common felt rings. There are also closed covers used in applications where the shaft does not pass.

2.1

MATERIAL DE LOS RODAMIENTOS

BEARINGS MATERIAL

El material de los caminos de rodadura y de las bolas de los rodamientos debe contar con la dureza requerida y mantener las características cualitativas indicadas a continuación:

1. elevada resistencia contra los frecuentes esfuerzos que puedan causar fracturas por fatiga de la superficie en los caminos de rodadura, que regulan la vida útil del rodamiento.
2. elevada resistencia y elasticidad de los materiales para evitar la deformación, en el momento en que se aplican fuertes cargas sobre la superficie.
3. elevada resistencia a la abrasión, para contrastar eficazmente la fricción rasante entre jaula y bolas.
4. elevada resistencia a roturas causadas por impactos, fallos y/o averías imputables a aplicaciones erróneas o montajes impropios.
5. soportar pequeñas modificaciones que puedan verificarse con el tiempo, en lo que se refiere a la dimensión y la forma debidas a esfuerzos internos o a variaciones de la estructura.

GCr15 acero <JIS G4805> (acero con elevado contenido de carbono y cromo, para rodamientos), esta tipología de acero logra satisfacer las condiciones expuestas previamente. En la siguiente tabla se detalla su composición química.

The materials used to construct the rolling track and the bearing spheres must have the necessary hardness and maintain the qualities indicated below:

1. *elevated resistance against repeated straining that can cause fractures due to wear and tear on the surface of the rolling track which regulates the life of the bearing.*
2. *elevated resistance and elasticity of the materials in order to prevent deformation when heavy loads are applied to the surface.*
3. *elevated resistance to abrasion to effectively contrast against wear and tear between the cage and the sphere.*
4. *elevated resistance against breaking caused by collision, breakage and or breakdown due to incorrect application or improper assemblage.*
5. *small changes which could occur over time due to internal solicitation or structural variations.*

GCr15 steel <JIS G4805> (steel with and elevated carbon or chrome content for bearings), is type of steel which is capable of satisfying all of the above points and the chemical composition is shown in the following table.

Composición química del acero con elevado contenido de carbono y cromo para rodamientos
Chemical composition of high carbon chromium bearing steel

Clasificación <i>Class</i>	Símbolos <i>Symbols</i>	Carbono <i>Carbon</i>	Silicio <i>Silicon</i>	Manganeso <i>Manganese</i>	Fósforo <i>Phosphorus</i>	Azufre <i>Sulphur</i>	Cromo <i>Chromium</i>
	JIS	C	Si	Mn	P	S	JIS
1	SUJ 1	0,95 ~ 1,10	0,15 ~ 0,35	> 0,50	> 0,025	> 0,025	0,90 ~ 1,20
2	SUJ 2	0,95 ~ 1,10	0,15 ~ 0,35	> 0,50	> 0,025	> 0,025	1,30 ~ 1,60
3	SUJ 3	0,95 ~ 1,10	0,40 ~ 0,70	0,90 ~ 1,15	> 0,025	> 0,025	0,90 ~ 1,20

Para mantener constante la calidad en el tiempo, se efectúan los siguientes controles:

- análisis químicos de la composición
- exploraciones magnéticas
- pruebas de rumorosidad y vibración
- corrosión por contacto con sustancias ácidas
- controles visuales
- exámenes de la estructura al microscopio
- tests de dureza de los materiales
- pruebas de fatiga

In order to maintain the quality constant over time, the entire series of tests reported below are performed:

- *chemical analysis of the composition.*
- *magnetic exploration*
- *noise and vibration tests*
- *corrosion from contact with acid substances.*
- *visual inspection*
- *microscopic inspection*
- *hardness tests on the materials*
- *stress tests*

2.2

MATERIAL DE LAS JAULAS Y DE LOS REMACHES

CAGES AND RIVETS MATERIAL

La composición del material de fabricación de las jaulas respeta las normas JIS G 3141; las jaulas se fabrican con láminas de acero al carbono plegado, enfriado y prensado SPCC.

La composición del material de fabricación de los remaches respeta las normas JIS G 3507; roscas metálicas de acero al carbono SWRCH 12A.

The composition of the material used to construct the cages conforms to JIS G 3141 norms; the cages are constructed with carbon rolled steel sheets, cooled and pressed SPCC.

The composition of the material used to construct the rivets conforms to JIS G 3507 norms, metal threads of carbon steel SWRCH 12A.

2.3

MATERIAL DEL CUERPO

HOUSING MATERIAL

La composición del material de fabricación de los cuerpos de los soportes es HT 200 JIS G 5501 (fundición). En la siguiente tabla se detallan sus propiedades mecánicas:

The composition of the construction material used to fuse the housings is HT 200 JIS G 5501 (cast iron), the mechanical properties of which are illustrated in the following table:

Propiedades mecánicas de las partes de fundición HT200 - *Mechanical properties of cast iron HT 200*

Clasificación Class	Espesor Thickness	Diámetro de la barra de prueba Diameter of testing bar	Test de tensión Tension test	Test de frenado lateral Traverse breaking test		Resistencia a la presión Pressure strength	Test de dureza Hardness test
			Fuerza de tensión Tensile strenght	Fuerza de curvado Bender strength	Deflexión Deflection		
	mm	mm	Kgf/mm ²	Kgf/mm ²	mm	Kgf/mm ²	HB
HT 200 JIS (FC 200)	< 06-80	13	< 32	53	1,8	75	187-255
	< 08-15	20	< 25	45	2,5	75	170-241
	< 15-30	30	< 20	40	2,5	75	170-241
	< 30-50	45	< 18	34	3,0	75	170-241
	< 50	60	< 16	31	4,5	75	160-229

2.4

MATERIALES DE LOS OTROS COMPONENTES

OTHER COMPONENTS MATERIAL

En la siguiente tabla se indican los materiales más importantes utilizados en la fabricación de los principales accesorios de los soportes.

The principle materials used to construct the main accessories relative to the housings are indicated in the table below.

Componentes Components	Material utilizado Material used	Símbolos JIS JIS symbols	Números JIS JIS numbers
Manguito Adapter sleeve	Acero al carbono Carbon steel	S25C	JIS G 4051
Tuerca Nut	Acero al carbono Carbon steel	S25C	JIS G 4051
Arandela Washer	Láminas de acero al carbono plegadas en frío y prensadas Cold roller carbon steel sheet and strip	SPCC	JIS G 3141
Anillos obturadores Shaft seal	Caucho sintético nitrilo Synthetic nitrile rubber	-	-
Dispositivo de lubricación Slinger	Láminas de acero al carbono plegadas en frío y prensadas Cold roller carbon steel sheet and strip	SPCC	JIS G 3141
Tornillo hexagonal Hexagon set screw	Acero niquelado con cromo y molibdeno Nickel chromium molybdenum steel	SCM 435	JIS G 4105
Llave hexagonal Hexagon wrench key	Acero niquelado con cromo y molibdeno Nickel chromium molybdenum steel	SNM 630	JIS G 4103
Engrasador Grease nipple	Latón Brass	C 3604	JIS H 3250

Los rodamientos utilizados en los soportes **ISB®** prevén un sistema de obturación a ambos lados. Dicho sistema está constituido por la combinación de una obturación de caucho sintético fijada en el aro exterior (reforzada con acero y con el correspondiente labio) y un blindaje presente en el aro interior, que gira con el aro mismo. Este sistema de protección evita la salida de la grasa y toda posible infiltración de agentes contaminantes. Además de estas protecciones (como ya hemos dicho en el apartado 2) se pueden también montar dispositivos de protección adicionales, como por ejemplo tapas. La utilización sinérgica de ambos dispositivos de protección resulta particularmente indicada cuando existen agentes externos muy agresivos, polvo, líquidos o cuando la máquina trabaja a la intemperie.

*The bearings used in **ISB®** housings provide a sealing system on both sides.*

They are constructed with a seal which has synthetic rubber fixed to the external ring and is reinforced with the relative steel lip; while fixed on the inner ring there is a shield which turns together.

This protective system prevents grease from exiting and pollutants from entering.

In addition to what is reported above and as briefly mentioned in point n° 2., ulterior protection devices such as covers are available.

Both protection devices used at the same time is indicated in cases where the external agents are particularly aggressive such as dust, various liquids or for external use.

Las tolerancias de los rodamientos y de los soportes han sido normalizadas a nivel nacional e internacional de conformidad con las normas JIS. Los rodamientos se fabrican en general con clase de tolerancia estándar

The tolerances of the bearings and their housings have been normalized at both national and international levels and conform to JIS norms. Generally, the bearings are constructed according to standard tolerances.

d	diámetro nominal del agujero <i>nominal bore diameter</i>
Δd_{mp}	diferencia del diámetro del agujero respecto al valor nominal <i>deviation of bore diameter from nominal value</i>
V_{dp}	variación del diámetro del agujero <i>bore diameter variation</i>
D	diámetro nominal exterior <i>nominal outer diameter</i>
ΔD_{mp}	diferencia del diámetro exterior medio respecto al valor nominal <i>deviation of the mean outer diameter from nominal value</i>
K_{ia}	concentricidad de rotación del aro interior en el rodamiento completo (precisión radial de rotación) <i>concentricity radial run out of assembled bearing inner ring (run out radial precision)</i>
K_{ea}	concentricidad de rotación del aro exterior en el rodamiento completo (precisión radial de rotación) <i>concentricity radial run out of assembled bearing outer ring (run out radial precision)</i>
ΔB_s	diferencia de una única medida de la altura del aro interior respecto a la dimensión nominal <i>inner ring single height deviation as regards to nominal dimension</i>
ΔC_s	diferencia de una única medida de la altura del aro exterior respecto a la dimensión nominal <i>outer ring single height deviation as regards to nominal dimension</i>

Aro interior - Inner ring

Diámetro interior (d) Inner diameter (d)				Tipo (rodamiento con agujero cilíndrico) Type (cylindrical bore bearing) UC - HC - SA - SB - SER				Diferencia altura Height deviation				Concentricidad de rotación Concentricity radial run out			
Más de Over		Hasta Up to		Δd_{mp}				V_{dp}		ΔB_s		ΔC_s		K_{ia}	
mm	pulgadas inch	mm	pulgadas inch	máx	mín	máx	mín	máx		mín	máx	mín	máx	máx	
10	0,3937	18	0,7087	+15	0	+6	0	10	4	0	-120	0	-47	15	6
18	0,7087	30	1,1811	+18	0	+7	0	12	5	0	-120	0	-47	18	7
30	1,1811	50	1,9685	+21	0	+8	0	14	6	0	-120	0	-47	20	8
50	1,9685	80	3,1496	+24	0	+9	0	16	6	0	-150	0	-59	25	10
80	3,1496	120	4,7244	+28	0	+11	0	19	7	0	-200	0	-79	30	12
120	4,7244	180	7,0866	+33	0	+13	0	22	9	0	-250	0	-98	35	14

Aro interior - Inner ring

Diámetro interior (d) Inner diameter (d)				Tipo (rodamiento con agujero cilíndrico) Type (cylindrical bore bearing) CB				Diferencia altura Height deviation				Concentricidad de rotación Concentricity radial run out			
Más de Over		Hasta Up to		Δd_{mp}				V_{dp}		ΔB_s		ΔC_s		K_{ia}	
mm	pulgadas inch	mm	pulgadas inch	máx	mín	máx	mín	máx		mín	máx	mín	máx	máx	
10	0,3937	18	0,7087	0	-8	0	-3	10	4	0	-120	0	-47	15	6
18	0,7087	30	1,1811	0	-10	0	-4	12	5	0	-120	0	-47	18	7
30	1,1811	50	1,9685	0	-12	0	-5	14	6	0	-120	0	-47	20	8

Aro exterior - Outer ring

Diámetro exterior (d) Outer diameter (d)				Variación del diámetro exterior medio Deviation of the mean outer diameter				Concentricidad de rotación Concentricity radial run out	
Más de Over		Hasta Up to		ΔD_{mp}				K_{ea}	
mm	pulgadas inch	mm	pulgadas inch	máx	mín	máx	mín	máx	
18	0,7087	30	1,1811	0	-9	0	-4	15	6
30	1,1181	50	1,9685	0	-11	0	-4	20	8
50	1,9685	80	3,1496	0	-13	0	-5	25	10
80	3,1496	120	4,7244	0	-15	0	-6	35	14
120	4,7244	150	5,9055	0	-18	0	-7	40	16
150	5,9055	180	7,0866	0	-25	0	-10	45	18
180	7,0866	250	9,8425	0	-30	0	-12	50	20
250	9,8425	315	12,4016	0	-35	0	-14	60	24

Semiángulo del cono: α
 Half angle of cone: α

$$\alpha = 2^{\circ}23'9,4''$$

$$= 2.38594^{\circ}$$

$$= 0.041643 \text{ rad}$$

(conicidad 1:12)
 (taper-ratio 1:12)

Diámetro mayor teórico d_1 :
 Theoretical bigger diameter d_1 :

$$d_1 = d + \frac{1}{12}B \quad (\text{conicidad } 1:12)$$

$$\quad (\text{taper-ratio } 1:12)$$

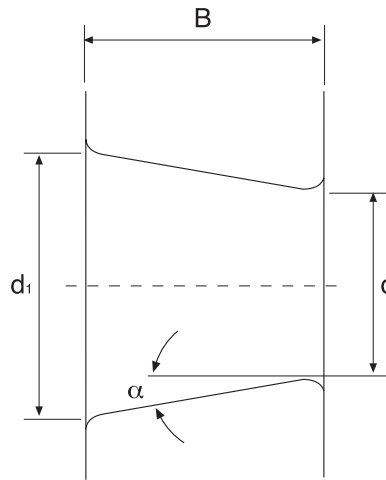

Agujero cónico teórico
 Theoretical bore diameter

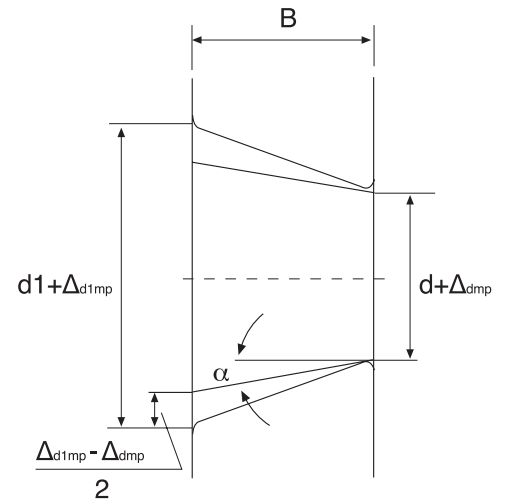

Agujero cónico con una diferencia en la dimensión del diámetro medio de la superficie plana
 Conical bore with deviation of mean diameter in flat surface

Δd_{mp}	Diferencia en la dimensión del diámetro medio del agujero en la superficie plana en el extremo menor teórico del agujero cónico <i>Deviation of mean bore diameter in a single plane (for a basically bore, Δd_{mp} refers to the theoretical small end of the conical bore)</i>
Δd_{1mp}	Diferencia en la dimensión del diámetro medio del agujero en la superficie plana en el extremo mayor teórico del agujero cónico <i>Deviation of mean bore diameter in a single plane at the theoretical large end of a basically conical bore)</i>
V_{dp}	Variación del diámetro del agujero <i>Bore diameter variation</i>
V_{dp}	Altura del aro interior <i>Inner ring height</i>

Aro interior (agujero cónico) - Inner ring (conical bore)

Diámetro interior (d) Inner diameter (d)				$+\Delta d_{mp}$				$\Delta d_{1mp} - \Delta d_{mp}$				$V_{dp}^{1)}$	
Más de Over		Hasta Up to		máx	mín	máx	mín	mín	máx	mín	máx	máx	
mm	pulgadas inch	mm	pulgadas inch										
18	0,7087	30	1,1811	+21	0	+8	0	+21	0	+8	0	13	5
30	1,1811	50	1,9685	+25	0	+10	0	+25	0	+10	0	15	6
50	1,9685	80	3,1496	+30	0	+12	0	+30	0	+12	0	19	7
80	3,1496	120	4,7244	+35	0	+14	0	+35	0	+14	0	25	10
120	4,7244	180	7,0866	+40	0	+16	0	+40	0	+16	0	31	12

1) Válido para todos los planos radiales del orificio - Valid for every radial flat of bore.

Tolerancia de la distancia (n) desde la línea central del aro exterior esférico al aro interior
Tolerance in distance (n) from centre line of spherical outer ring to side of inner ring

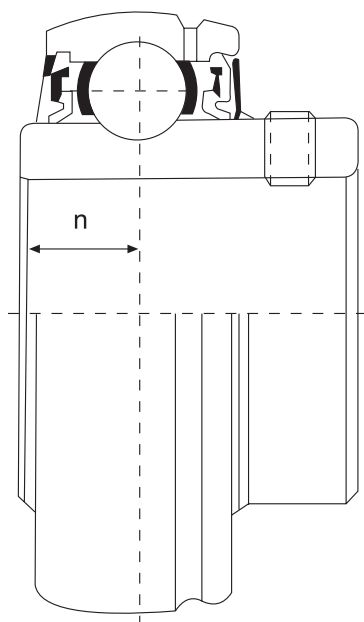

Diámetro interior (d) <i>Inner diameter (d)</i>				Tolerancia (n) <i>Tolerance (n)</i>	
Más de <i>Over</i>		Hasta <i>Up to</i>			
mm	pulgadas <i>inch</i>	mm	pulgadas <i>inch</i>		
2,5	0,0984	50	1,9685	±200	±79
50	1,9685	80	3,1496	±250	±98
80	3,1496	120	4,7244	±300	±118
120	4,7244	-	-	±350	±138

3.1

TOLERANCIAS DEL DIÁMETRO DEL ALOJAMIENTO

TOLERANCE OF SPHERICAL BORE DIAMETER OF HOUSING

Diámetro del agujero esférico del soporte
Spherical bore diameter of bearing units

Diámetro del agujero esférico (D _a) <i>Spherical bore diameter (D_a)</i>				Diferencia del diámetro medio del agujero (⁴ D _{am}) <i>Mean bore diameter deviation (⁴D_{am})</i>											
Más de <i>Over</i>		Hasta <i>Up to</i>		Tolerancia H7 <i>H7 tolerance</i>				Tolerancia J7 <i>J7 tolerance</i>				Tolerancia K <i>K tolerance</i>			
mm	pulgadas <i>inch</i>	mm	pulgadas <i>inch</i>	mín	máx	mín	máx	mín	máx	mín	máx	mín	máx	mín	máx
30	1,1811	50	1,9685	+25	0	+10	0	+14	-11	+6	-4	+7	-18	+3	-7
50	1,9685	80	3,1496	+30	0	+12	0	+18	-12	+7	-5	+9	-21	+4	-8
80	3,1496	120	4,7244	+35	0	+14	0	+22	-13	+9	-5	+10	-25	+4	-10
120	4,7244	180	7,0866	+40	0	+16	0	+26	-14	+10	-6	+12	-28	+5	-11
180	7,0866	250	9,8425	+46	0	+18	0	+30	-16	+12	-6	+13	-33	+5	-13
250	9,8425	315	12,4016	+52	0	+20	0	+36	-16	+14	-6	-	-	-	-

3.2

TOLERANCIAS DE LOS SOPORTES

BEARING UNITS TOLERANCES

Tipos de soportes de pie <i>Bearing units type</i>						Tolerancia h <i>Tolerance h</i>
P203	-	-	-	-	-	±150
P204	-	-	HP204	UP204	PL204	
P205	P305	PX05	HP205	UP205	PL205	
P206	P306	PX06	HP206	UP206	PL206	
P207	P307	PX07	HP207	UP207	PL207	
P208	P308	PX08	HP208	UP208	-	
P209	P309	PX09	HP209	UP209	PL209	
P210	P310	PX10	HP210	UP210	PL210	
P211	P311	PX11	-	-	-	
P212	P312	PX12	-	-	-	
P231	P313	PX13	-	-	-	
P214	P314	PX14	-	-	-	
P215	P315	PX15	-	-	-	
P216	P316	PX16	-	-	-	
P217	P317	PX17	-	-	-	
P218	P318	PX18	-	-	-	
-	P319	-	-	-	-	±300
-	P320	PX20	-	-	-	
-	P321	-	-	-	-	
-	P322	-	-	-	-	
-	P324	-	-	-	-	
-	P326	-	-	-	-	
-	P328	-	-	-	-	

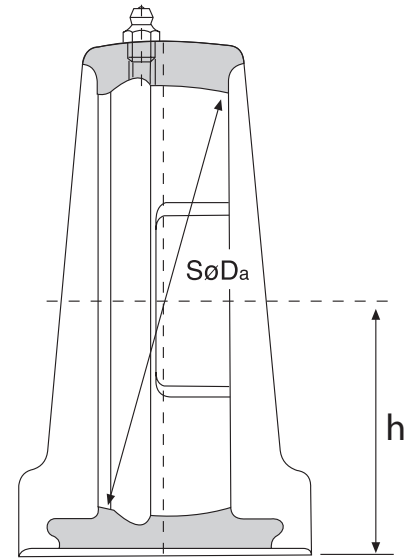

3.3

TOLERANCIAS DE LOS SOPORTES DE BRIDA

FLANGE BEARING UNITS TOLERANCES

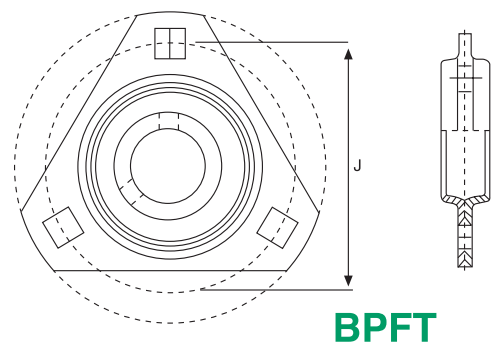
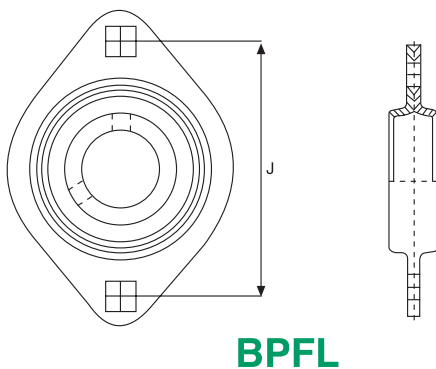
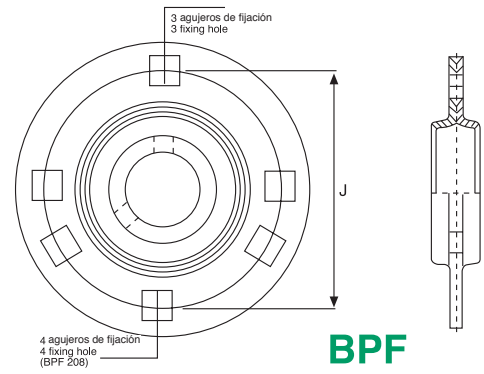
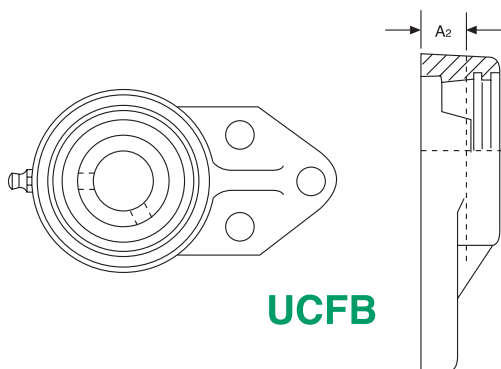
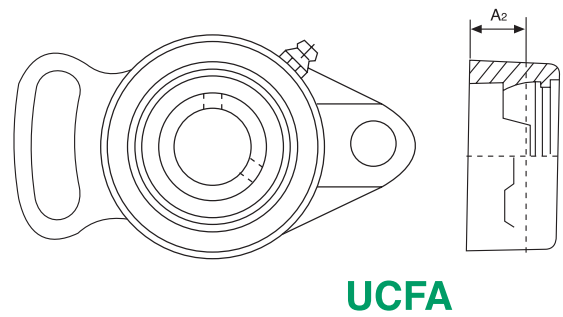
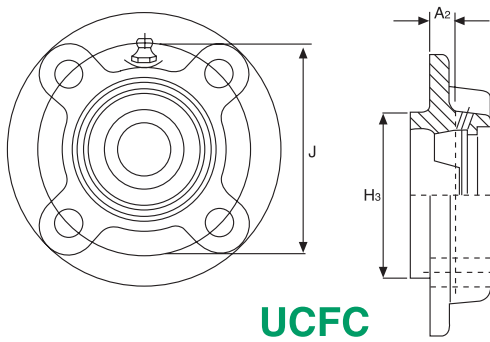
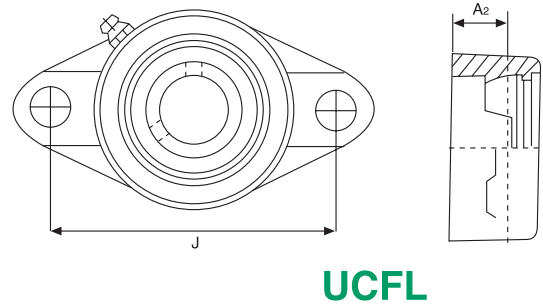
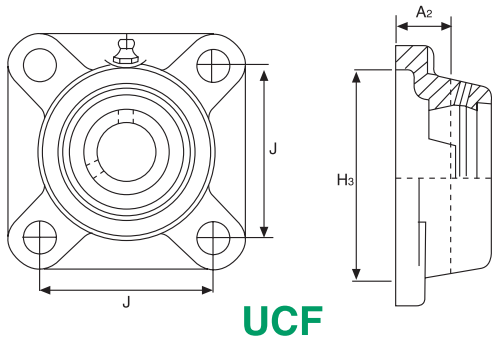

Tipos de soportes de brida Flange bearing units type							Tolerancia J Tolerance		Tolerancia A₂ Tolerance		Diferencias H ₃ H ₃ deviation								Tolerancia A₂ Tolerance					
											FC2				FCX						FS3			
											máx	mín	máx	mín	máx	mín	máx	mín			máx	mín	máx	mín
F204	-	-	FC204	-	FL204	-	±700	±276	±500	±197	-	-	-	-	-	-	-	-	200	79				
F205	F305	FX05	FC205	FS305	FL205	FL305					0	-46	0	-18	0	-46	0	-18			0	-46	0	-18
F206	F306	FX06	FC206	FS306	FL206	FL306					0	-54	0	-21	0	-54	0	-21			0	-54	0	-21
F207	F307	FX07	FC207	FS307	FL207	FL307					0	-54	0	-21	0	-54	0	-21			0	-54	0	-21
F208	F308	FX08	FC208	FS308	FL208	FL308					0	-54	0	-21	0	-54	0	-21			0	-54	0	-21
F209	F309	FX09	FC209	FS309	FL209	FL309					0	-54	0	-21	0	-54	0	-21			0	-54	0	-21
F210	F310	FX10	FC210	FS310	FL210	FL310	±1000	±394	±800	±315	0	-63	0	-25	0	-63	0	-25	0	-63	0	-25	300	118
F211	F311	FX11	FC211	FS311	FL211	FL311					0	-63	0	-25	0	-63	0	-25	0	-63	0	-25		
F212	F312	FX12	FC212	FS312	FL212	FL312					0	-63	0	-25	0	-63	0	-25	0	-63	0	-25		
F213	F313	FX13	FC213	FS313	FL213	FL313					0	-63	0	-25	0	-63	0	-25	0	-63	0	-25		
F214	F314	FX14	FC214	FS314	FL214	FL314					0	-63	0	-25	0	-63	0	-25	0	-63	0	-25		
F215	F315	FX15	FC215	FS315	FL215	FL315					0	-63	0	-25	0	-63	0	-25	0	-63	0	-25		
F216	F316	FX16	FC216	FS316	FL216	FL316	±1000	±394	±800	±315	0	-72	0	-28	0	-72	0	-28	0	-72	0	-28	400	157
F217	F317	FX17	FC217	FS317	FL217	FL317					0	-72	0	-28	0	-72	0	-28	0	-72	0	-28		
F218	F318	FX18	FC218	FS318	FL218	FL318					0	-72	0	-28	0	-72	0	-28	0	-72	0	-28		
-	F319	-	-	FS319	-	FL319					0	-72	0	-28	0	-72	0	-28	0	-72	0	-28		
-	F320	FX20	-	FS320	-	FL320					0	-72	0	-28	0	-72	0	-28	0	-72	0	-28		
-	F321	-	-	FS321	-	FL321					0	-72	0	-28	0	-72	0	-28	0	-72	0	-28		
-	F322	-	-	FS322	-	FL322	-	-	-	-	-	-	-	-	-	-	-	-	400	157				
-	F324	-	-	FS324	-	FL324	-	-	-	-	-	-	-	-	-	-	-	-						
-	F326	-	-	FS326	-	FL326	-	-	-	-	-	-	-	-	-	-	-	-						
-	F328	-	-	FS328	-	FL328	-	-	-	-	-	-	-	-	-	-	-	-						

3.4 TOLERANCIAS DE LOS SOPORTES TENSORES Y DE CARTUCHO CILÍNDRICO TAKE-UP AND CYLINDRICAL CARTRIDGE BEARING UNITS TOLERANCES

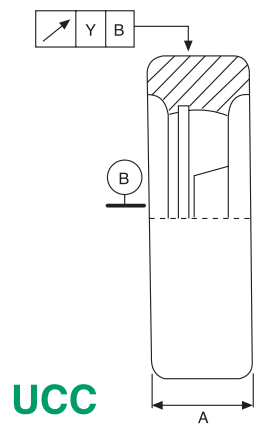
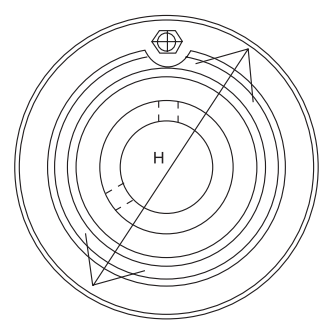
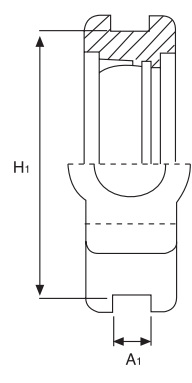
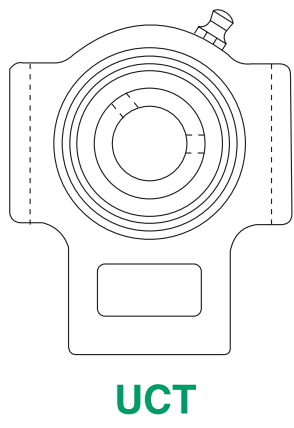

Tipos de soportes tensores Take-up bearing units type			Tolerancia A ₁ Tolerance		Tolerancia H ₁ Tolerance		Paralelismo de guía Parallelism of sliding bolt		Tipos de soportes de cartucho Cylindrical cartridge bearing units type			Tolerancia H H Tolerance						Defecto radial Y Spigot run-out máx		Diferencia A Deviation			
			máx mín	máx mín	máx mín	máx mín						C2...		CX...		C3...							
												máx mín	máx mín	máx mín	máx mín	máx mín	máx mín						
T2...	TX...	T3...							C2...	CX...	C3...												
T204	-	T304							C204	CX204	C304	0	0	-	-	-	-						
T205	TX205	T305	+200 0	+79 0	0 -500	0 -197	500	197	C205	CX205	C305	-30	-12										
T206	TX206	T306							C206	CX206	C306			0	0	0	0	0	0	200	79	±200	±79
T207	TX207	T307							C207	CX207	C307			-35	-14	-35	-14						
T208	TX208	T308							C208	CX208	C308			0	0								
T209	TX209	T309							C209	CX209	C309			-35	-14								
T210	TX210	T310																					
T211	TX211	T311							C211	CX211	C311			0	0								
T212	TX212	T312							C212	CX212	C312	0	0	-40	-16	-40	-16						
T213	TX213	T313							C213	-	C313												
T214	TX214	T314							-	-	C314												
T215	TX215	T315						600	236	-	-	C315											
T216	TX216	T316							-	-	C316												
T217	TX217	T317							-	-	C317			0	0	-46	-18						
-	-	T318	+300 0	+118 0	0 -800	0 -315			-	-	C318							±300	±118				
-	-	T319							-	-	C319												
-	-	T320							-	-	C320												
-	-	T321						700	276	-	-	C321			0	0	-52	-20					
-	-	T322							-	-	C322												
-	-	T324							-	-	C324												
-	-	T326						800	315	-	-	C326			0	0	-57	-22					
-	-	T328							-	-	C328												

3.5 TOLERANCIAS DE LOS EJES SHAFTS TOLERANCES

Las tolerancias de los ejes están influenciadas y determinadas principalmente por dos factores: el diámetro y el número de giros que debe cumplir el eje. Si el eje debe cumplir un número reducido de giros se podrán utilizar tolerancias h 9, si en cambio debe cumplir un número elevado de giros es preferible utilizar tolerancias menores.

The tolerances of the shafts are influenced and determined mainly by two factors: the diameter and the number of rounds to be completed. Should the shaft require a low number of rounds, the tolerance can be h9, whereas, if the shaft requires a higher number of rounds it is preferable to use a more narrow tolerance.

Tolerancias del eje para rodamientos serie UC - SB - SA
Shaft tolerance for UC - SB - SA bearings series

Dimensión del eje (d) Shaft dimension (d)				Tolerancia del diámetro del eje Diameter shaft tolerance							
Oltrev Over		Hasta Up to		j6		h6		h7		h8	
mm	pulgadas inch	mm	pulgadas inch	dn > 120 000		dn ≤ 120.000		dn ≤ 100.000		dn ≤ 60.000	
10	0,3937	18	0,7087	+8 ~ -3	+3 ~ -1	0 ~ -11	0 ~ -4	0 ~ -18	0 ~ -7	0 ~ -27	0 ~ -11
18	0,7087	30	1,1811	+8 ~ -4	+4 ~ -2	0 ~ -13	0 ~ -5	0 ~ -21	0 ~ -8	0 ~ -33	0 ~ -13
30	1,1811	50	1,9685	+11 ~ -5	+4 ~ -2	0 ~ -16	0 ~ -6	0 ~ -25	0 ~ -10	0 ~ -39	0 ~ -15
50	1,9685	80	3,1496	+12 ~ -7	+5 ~ -3	0 ~ -19	0 ~ -7	0 ~ -30	0 ~ -12	0 ~ -46	0 ~ -18
80	3,1496	120	4,7244	+13 ~ -9	+5 ~ -4	0 ~ -22	0 ~ -9	0 ~ -35	0 ~ -14	0 ~ -54	0 ~ -21
120	4,7244	180	7,0866	+14 ~ -11	+6 ~ -4	0 ~ -25	0 ~ -10	0 ~ -40	0 ~ -16	0 ~ -63	0 ~ -25

Tolerancias del eje para rodamientos serie UK
Shaft tolerance for UK bearings series

Dimensión del eje (d) Shaft dimension (d)				Tolerancia del diámetro del eje Diameter shaft tolerance							
Oltrev Over		Hasta Up to		h8		h9		h10		h11	
mm	pulgadas inch	mm	pulgadas inch	Superior Upper		Inferior Lower		Superior Upper		Inferior Lower	
10	0,3937	18	0,7087	0 - 27	0 - 11	- -	- -	- -	- -	- -	- -
18	0,7087	30	1,1811	0 - 33	0 - 13	0 - 52	0 - 20	0 - 84	0 - 33	0 - 120	0 - 47
30	1,1811	50	1,9685	0 - 39	0 - 15	0 - 62	0 - 24	0 - 100	0 - 39	0 - 160	0 - 63
50	1,9685	80	3,1496	0 - 46	0 - 18	0 - 74	0 - 29	0 - 120	0 - 47	0 - 190	0 - 75
80	3,1496	120	4,7244	0 - 54	0 - 21	0 - 87	0 - 34	0 - 140	0 - 55	0 - 200	0 - 79
120	4,7244	180	7,0866	0 - 63	0 - 25	0 - 100	0 - 39	0 - 160	0 - 63	0 - 250	0 - 98

3.6

PRECISIÓN DIMENSIONAL DE LAS FUNDICIONES

DIMENSIONAL ACCURACIES OF CASTINGS

Para saber el grado de precisión dimensional de las fundiciones, cuando este valor no está especificado, será conveniente tomar como referencia el estándar **JIS B 0405** (valor que representa la diferencia media dimensional admisible, cuando no se cuenta con la indicación de un valor).

When the dimensional accuracy of the casting is not specified simply refer to the **JIS B 0405** standard (the average deviation admissible in absence of indicated values).

Dimensiones Dimensions				Tolerancia dimensional de la clase media Middle class dimensional tolerance	
Superior Upper		Incluido Included			
mm	pulgadas inch	mm	pulgadas inch		
0,5	0,0197	6	0,2362	±100	±39
6	0,2362	30	1,1811	±200	±79
30	1,1811	120	4,7244	±300	±118
120	4,7244	315	12,4016	±500	±197
315	12,4016	1000	39,3701	±800	±315

3.7

TOLERANCIAS DE LAS FUNDICIONES

CASTINGS TOLERANCES

La precisión dimensional de la fundición sigue el estándar **JIS B 0407** (diferencia media de las dimensiones cuando no existe indicación sobre la tolerancia de la fundición).

The dimensional accuracy of the castings is done according to **JIS B 0407** (average deviation of the dimensions when the tolerance is absent from the casting).

Tolerancia en la longitud <i>Tolerance in length</i>						Tolerancia en el espesor <i>Tolerance in thickness</i>					
Dimensiones <i>Dimensions</i>				Tolerancia <i>Tolerance</i>		Dimensiones <i>Dimensions</i>				Tolerancia <i>Tolerance</i>	
Superior <i>Over</i>		Incluido <i>Included</i>				Superior <i>Over</i>		Incluido <i>Included</i>			
mm	pulgadas <i>inch</i>	mm	pulgadas <i>inch</i>			mm	pulgadas <i>inch</i>	mm	pulgadas <i>inch</i>		
-	-	120	4,7244	±1500	±591	-	-	-	-	-	-
120	4,7244	250	9,8425	±2000	±787	-	-	10	0,3937	±1500	±591
250	9,8425	400	15,7480	±3000	±1181	10	0,3937	18	0,7087	±2000	±787
400	15,7480	800	31,4961	±4000	±1575	18	0,7087	30	1,1811	±3000	±1181
800	31,4961	1600	62,9921	±6000	±2362	30	1,1811	50	1,9685	±3500	±1378

3.8 CARGA ADMISIBLE DE LOS SOPORTES ALLOWED LOAD BEARING UNITS

La capacidad de carga de los soportes está determinada principalmente por dos factores:

- la forma
- el sentido de la carga.

Como cada soporte tiene su forma propia particular y características específicas puede resultar difícil calcular las capacidades de carga admitidas.

De todos modos es siempre conveniente prestar atención al sentido de la fuerza aplicada, que puede ser hacia abajo, hacia arriba, horizontal o axial.

The housing load is determined principally by two factors:

- *the form*
- *the direction of the load*

As each housing has different characteristics in different forms, it can be difficult to calculate the permitted load capacity.

In any case, it is always helpful to consider the direction of the force applied. The direction can be upward, downward, horizontal or axial.

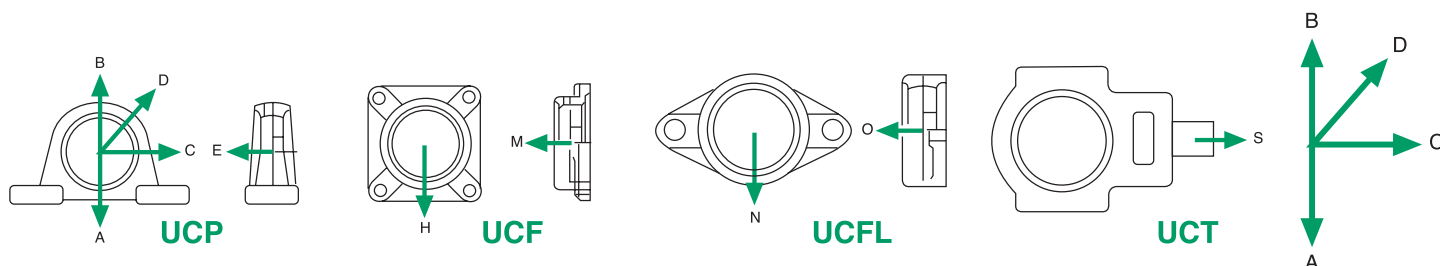

A/H/N Dirección hacia abajo
B Dirección hacia arriba
C/S Dirección horizontal
D Dirección a 45°
E/M/O Dirección axial

A/H/N Downward direction
B Upward direction
C/S Horizontal direction
D 45° direction
E/M/O Axial direction

Dimensiones Dimensions	Carga estática de rotura - Static ratings load									
	Tipo - Type					Tipo - Type		Tipo - Type		Tipo - Type
	UCP					UCF		UCFL		UCT
	A	B	C	D	E	H	M	N	O	S
203	69	29	49	22	10	-	-	-	-	-
204	79	32	54	24	16	42	17	23	11	33
205	92	36	59	27	17	65	24	37	15	37
206	117	49	88	34	21	65	29	37	19	40
207	156	59	98	43	23	63	35	40	22	56
208	176	64	107	45	24	69	38	40	26	80
209	186	68	117	48	25	98	46	60	31	76
210	186	73	137	55	31	98	49	60	38	84
211	205	80	147	58	33	90	55	72	43	95
212	274	107	166	71	43	90	60	86	47	98
213	284	117	186	81	49	166	67	96	60	127
214	313	117	196	82	54	186	74	98	68	127
215	323	127	205	90	56	186	78	107	70	127
216	352	147	264	107	64	166	84	127	84	137
217	441	166	274	117	73	205	93	137	92	156
218	470	186	323	127	117	245	107	137	137	-

3.9

CARGA ADMISIBLE DE LOS SOPORTES EN CHAPA ESTAMPADA

ALLOWED LOAD OF PRESSED STEEL HOUSINGS

Los soportes de chapa estampada **ISB**[®] podrían sufrir deformaciones cuando son sometidos a cargas. El grado de deformación dependerá del sentido y de la intensidad de la carga misma. También la forma del soporte y el espesor de las láminas de chapa pueden influir en la magnitud de dichas deformaciones.

Se deduce por lo tanto que la carga resulta admisible cuando la deformación que provoca no perjudica la funcionalidad del soporte mismo.

La carga admitida será aproximadamente 1/3 del valor de la carga base en sentido radial y 1/3 de la carga radial permitida en sentido axial.

*When the housings in sheets stamped **ISB**[®] are subjected to loads, deformations could present themselves. Such deformations may vary according to the direction of the total load itself, furthermore, also the form of the housing or the thickness of the sheet can influence the entity of the deformations. From all of the above we can deduct that the allowable load should be such that the deformation provoked does not prejudice the functionality of the housing itself. The allowable load will be approximately 1/3 of the base load value in a radial direction and 1/3 of the radial load permitted in axial direction*

3.10

COEFICIENTES DE SEGURIDAD

SAFETY FACTOR

Antes de emplear un soporte es necesario determinar la intensidad y el sentido de la carga, teniendo en cuenta los correspondientes coeficientes de seguridad. Para establecer la carga admisible es necesario dividir el valor de la carga estática de rotura por el coeficiente de seguridad.

Before using a housing unit it is necessary to determine the intensity and direction of the load considering the pertinent factor of security. To establish the admissible load it is necessary to divide the value of static load by the security factor.

Condiciones de carga <i>Load conditions</i>	Carga permanente <i>Permanent load</i>	Carga vibratoria <i>Vibratory load</i>	Carga imprevista <i>Unexpected load</i>
Coefficiente de seguridad <i>Safety factor</i>	4	10	15

3.11 VELOCIDAD MÁXIMA (RPM)

MAX RPM.

Tipo <i>Type</i>	Diámetro <i>Diameter</i>	Tolerancia máx. admisible nº giros <i>Max rpm.</i>			
		j7	h7	h8	h9
UC-SB	mm				
201	12	6700	5900	4300	1600
202	15	6700	5500	4000	1500
203	17	6700	5300	3800	1400
204	20	6700	4900	3500	1250
205	25	5600	4100	2900	1050
206	30	4700	3400	2400	880
207	35	4000	3000	2100	760
208	40	3600	2600	1900	680
209	45	3300	2400	1700	620
210	50	3000	2200	1600	570
211	55	2700	2000	1400	510
212	60	2400	1800	1250	460
213	65	2300	1700	1150	420
214	70	2200	1600	1100	400
215	75	2000	1500	1000	380
216	80	1900	1400	960	350
217	85	1800	1300	900	330
218	90	1700	1200	840	310
-	-	-	-	-	-
-	-	-	-	-	-
-	-	-	-	-	-

Tipo <i>Type</i>	Diámetro <i>Diameter</i>	Tolerancia máx. admisible nº giros <i>Max rpm.</i>			
		j7	h7	h8	h9
UC-SB	mm				
305	25	5000	3700	2600	940
306	30	4300	3100	2200	800
307	35	3800	2800	2000	720
308	40	3400	2500	1700	640
309	45	3000	2200	1500	560
310	50	2700	2000	1400	500
311	55	2500	1800	1300	470
312	60	2300	1700	1150	430
313	65	2100	1500	1100	400
314	70	2000	1400	1000	370
315	75	1800	1300	930	340
316	80	1700	1250	870	320
317	85	1600	1150	810	300
318	90	1500	1100	760	280
319	95	1400	1000	720	260
320	100	1300	940	660	240
321	105	1250	900	630	230
322	110	1200	830	590	210
324	120	1100	750	530	190
326	130	1000	680	480	180
328	140	900	620	440	160

4 COEFICIENTES DE CARGA Y VIDA ÚTIL

LOAD RATINGS AND LIFE

La vida útil de los rodamientos se puede definir como el número de giros o de horas de funcionamiento que el rodamiento es capaz de soportar antes que aparezcan los primeros signos de fatiga en uno de sus aros, en el camino de rodadura o en los elementos rodantes. La causa de dichas fatigas son los continuos esfuerzos a los que están sometidos los materiales que componen los rodamientos. Existen sin embargo otros factores que pueden influenciar la vida útil de un rodamiento, como por ejemplo, la abrasión, la corrosión, el agarrotamiento y la oxidación.

The life of rotating bearings can be defined as the number of rounds or by the functioning hours, that the bearing is capable of withstanding before showing the first signs of wear on one of the rings, on the rotating track or on the rotating elements. Such signs of wear are caused by repeated use and are influenced by the composition materials of the bearings.

There are in any case other factors that can influence the life of a bearing; for example, abrasion, corrosion, the binding, oxidation and rust.

Estos problemas se pueden presentar en caso de aplicaciones inadecuadas, montajes incorrectos o bien por una lubricación escasa o ausente. Los citados inconvenientes no pueden ser considerados como fallo de los materiales, ya que podrían ser evitados tomando las precauciones necesarias. Cuando se desee tener en cuenta sólo la fatiga en las superficies de trabajo del rodamiento, se deberán respetar las siguientes condiciones:

1. Las fuerzas y las velocidades tomadas en cuenta para la evaluación del rodamiento deberán corresponder a las que se registran en las condiciones reales de funcionamiento.
2. Durante todo el período de servicio deberá garantizarse una adecuada lubricación.
3. La experiencia demuestra como los fallos en muchos rodamientos son imputables a causas distintas a la fatiga del material, como por ejemplo: selección de un rodamiento inadecuado, defectos de funcionamiento o de lubricación, presencia de partículas extrañas en el rodamiento y otras causas.

La vida útil con fatiga nominal de un rodamiento o de un grupo de rodamientos idénticos y operantes a idénticas condiciones de servicio, consiste en la durabilidad de servicio equivalente al menos a un grado de fiabilidad del 90%.

La vida útil media de un grupo de rodamientos es muy superior a la vida útil nominal.

La vida útil a la fatiga nominal se expresa con L_{10} (millones de giros - coeficiente de carga dinámica) o L_{10h} (horas de servicio). La siguiente ecuación permite calcular la relación entre la vida útil nominal, el coeficiente de carga dinámica y la carga incidente sobre el rodamiento:

$$L_{10} = \left(\frac{C}{P} \right)^p$$

donde:

- L_{10} vida útil nominal expresada en 10^6 de giros
- C coeficiente de carga dinámica del rodamiento, expresado en N
- P carga dinámica equivalente sobre el rodamiento, expresada en N
- p exponente de vida útil de la ecuación, con los siguientes valores:
- $P=$ 3 para los rodamientos de bolas
- $p=$ 10/3 para los rodamientos de rodillos

These types of problems can present themselves due to eventual applications which are not fit or due to mounting errors or for insufficient or lack of lubrication. The above mentioned problems should be considered differently from problems with materials that yield because they can be avoided by the necessary precautions. Where one considers only the wear and tear on the working surface of the bearing, the following conditions should be observed:

1. *The force and speed of the bearing as explained should correspond to the real conditions of the exercise in order to evaluate the bearing.*
2. *During the entire exercise period the adequate lubrication should be assured.*
3. *Experience has shown us that the yielding of many bearings can be attributed to causes other than wear and tear, such as: the choice of an adequate bearing, functional or lubrication defects, the presence of foreign particles in the bearing and other things.*

The life at nominal wear of a single bearing or of a sampling of identical bearings and operating under identical conditions of exercise, consists in the length of the exercise equal to at least a 90% level of reliability. The average life of a group of bearings is well above the nominal life. The life at nominal wear and tear is expressed as L_{10} (millions of rounds - the coefficient of a dynamic load) or L_{10h} (hours of exercise). The equation illustrated below calculates the relation between the nominal life and the coefficient of the dynamic load and the agent load on the bearing:

where:

- L_{10} *the nominal life expresses 10^6 rounds*
- C *the coefficient of the dynamic load of the bearing, expressed in N*
- P *the dynamic load equivalent on the bearing, expressed in N*
- p *the exponent of the length of the equation with the following values:*
- $P=$ *3 for spherical bearings*
- $p=$ *10/3 for roller bearings*

Para los rodamientos que trabajan a velocidad constante la vida útil con fatiga nominal, expresada en horas de funcionamiento, podrá calcularse con la siguiente ecuación:

For bearings used at constant speeds, the life at nominal wear and tear, expressed in functioning hours, can be calculated with the present equation:

$$L_{10h} = \left(\frac{10^6}{n \cdot 60} \right) \left(\frac{C}{P} \right)^p$$

donde:

where:

n velocidad de rotación expresada en rpm

n the speed of rotation, expressed in rounds per minutes

Para determinar las medidas adecuadas que deberá tener el rodamiento, es necesario basar los cálculos de vida útil a la fatiga nominal teniendo en cuenta la utilización efectiva del rodamiento. Generalmente esto depende del tipo de máquina, de la durabilidad requerida y de los requisitos inherentes a la seguridad de funcionamiento.

In the determination of the dimensions of the bearing it is necessary to base the calculations on the life at nominal wear and tear corresponding to the effective use. Usually this depends on the type of machine, the life requested and on the inherent functioning safety.

En la siguiente tabla se expone la relación entre el régimen de rotación y el coeficiente de velocidad y la relación entre la vida útil nominal y el coeficiente de vida útil

The relation between the rotation regime and the speed factor as well as the relation between the nominal life and the life factor are explained in the table below.

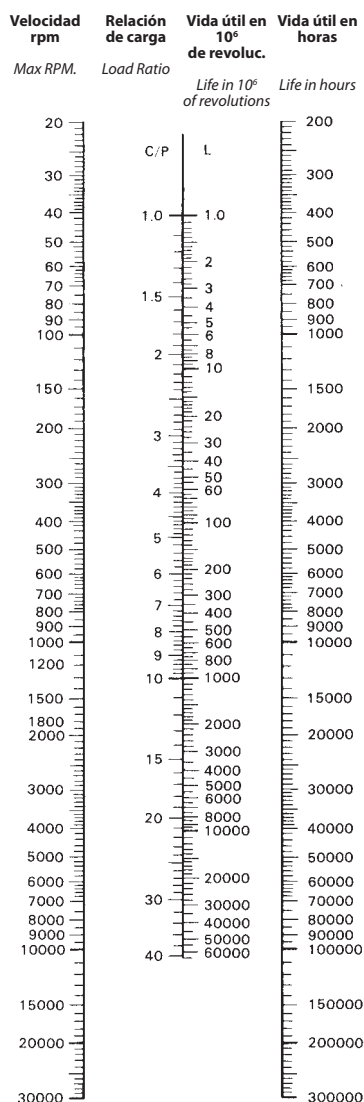

4.1

COEFICIENTE DE CARGA ESTÁTICA C_0

STATIC LOAD RATINGS C_0

El coeficiente de carga estática C_0 se podrá tomar en cuenta cuando el rodamiento es estacionario o está sujeto a rotaciones y/u oscilaciones muy lentas (inferiores a 10 rpm). Por lo tanto el coeficiente de carga estática no se determinará en función de la fatiga del material, sino en base a la deformación permanente inducida en el punto de contacto entre la superficie rodante y el camino de rodadura.

Para los rodamientos radiales, la carga se expresa en sentido radial y el punto de presión entre los cuerpos rodantes y los caminos de rodadura pueden alcanzar los siguientes valores:

4.200 N/mm² para los rodamientos de bolas

En las citadas condiciones, el coeficiente de carga estática C_0 corresponde aproximadamente a la deformación del elemento rodante más cargado y a la deformación de uno de los caminos de rodadura, igual a 1/10 000 del diámetro del cuerpo rodante. Estas consideraciones resultarán válidas en condiciones normales de servicio y la deformación podrá ser tolerada sin perjuicios para la eficiencia del funcionamiento.

The static load coefficient C_0 can be considered when the bearing is stationary or subject to rotation and or particularly slow oscillation (below 10 rounds max. per minute), therefore the coefficient of the static load will not be determined in function of the wear on the material, but based on the permanent deformation induced at the point of contact between the rotating surface and the rolling track.

As for radial bearings, the load is expressed in radial direction and the pressure point between the rotating bodies and the rolling track can reach the following values:

4 200 N/mm² per spherical bearings

In conditions indicated above, the coefficient of the static load C_0 , corresponds approximately to the deformation of the rotating element plus the load and to the deformation of one of the rolling tracks equal to 1/10 000 of the diameter of the rotating body. All of the above can be considered valid in normal conditions of use and the deformation can be tolerated, without prejudicing the functioning efficiency.

4.2

COEFICIENTE DE SEGURIDAD ESTÁTICO S_0

STATIC LOAD SAFETY FACTOR S_0

Por lo tanto la capacidad de carga estática determina el valor que un rodamiento puede soportar cuando gira bajo carga muy lentamente o en condición estacionaria. Estas cargas pueden de todos modos crear deformaciones, a veces permanentes, por lo tanto es importante tener en cuenta también el correspondiente coeficiente de seguridad del rodamiento.

El coeficiente de seguridad estático, puede calcularse con la siguiente fórmula:

$$S_0 = \frac{C_0}{P_0}$$

considerando que:

- S_0 - coeficiente de seguridad estático
- C_0 - coeficiente de carga estática (Kg., N)
- P_0 - carga máxima admisible (Kg., N)

For all of the above, the static load capacity, determines the value that a bearing is capable of supporting if subjected to loads, but in absence or in the reduced presence of movement. These loads can anyway create deformations, sometimes permanent, for this reason it is important to consider the concept of the safety factor of the bearing against eventual deformation.

The static safety factor can be determined using the following formula:

consider that:

- S_0 - static safety factor
- C_0 - static load coefficient (Kg.,N)
- P_0 - maximum load allowable (Kg.,N)

Valores indicativos del coeficiente de seguridad estático S_0
So static safety load rating coefficient

Condiciones operativas <i>Working conditions</i>	Rodamientos de bolas <i>Roller bearings</i>
Elevada precisión de rotación, con cargas e impactos <i>High rotation precision, with heavy loads and impact</i>	2
Precisión normal de rotación, con mayores exigencias de silenciosidad <i>Normal rotation precision, with greater need of noiselessness</i>	1
Precisión de rotación limitada, bajas cargas, mínimas exigencias de silenciosidad <i>Low rotation precision, low loads and minimal need of noiselessness</i>	0,5

4.3

CARGA RADIAL DINÁMICA Y ESTÁTICA EQUIVALENTE EQUIVALENT RADIAL DYNAMIC AND STATIC LOAD

En las tablas de medidas, se indican los valores de los coeficientes de carga dinámica C_r y estática C_{or} . Estos valores se tienen en cuenta cuando la carga tiene sentido exclusivamente radial. Pero los rodamientos generalmente están sometidos a diversos tipos de cargas, como así también a otros esfuerzos, como impactos, vibraciones, etc. Por lo tanto es necesario convertir el valor de carga dinámica radial y axial en un único valor, denominado carga radial dinámica equivalente, para determinar así las reales cargas que inciden sobre el rodamiento y obtener un valor muy cercano a la vida útil del rodamiento montado en el soporte. La carga radial estática representa la contraparte de la carga radial dinámica equivalente de un rodamiento.

The dynamic C_r and static C_{or} load coefficient ratings are listed in the dimension tables. These ratings should be considered only when the load is purely in the radial direction; however, the bearings are often subject to several load agents, as well as other situations such as bumps, vibration etc.. therefore, the ratings of the dynamic radial and axial load should be converted to the same rating called the dynamic radial load equivalent. In this way, the rating of the real applied load obtained is very similar to the life of the bearing mounted on the housing. The static radial load represents the counterpart to the dynamic radial load equivalent of a bearing.

5

JUEGO DE LOS RODAMIENTOS DE BOLAS CLEARANCE OF BALL BEARINGS

Uno de los principales factores que pueden influenciar la vida útil del rodamiento es el juego. El juego del rodamiento o juego interior (juego inicial) representa el valor de juego de un rodamiento antes de montarlo sobre un eje o dentro del asiento de alojamiento. El juego de un rodamiento será axial o radial, según la dirección de desplazamiento del aro móvil. El juego radial se define como el valor medio de las diferentes medidas de desplazamiento total, en el plano perpendicular al eje del rodamiento. Dicho desplazamiento es típico de uno de los aros del rodamiento (el otro aro es fijo) durante su movimiento en las diferentes direcciones angulares, tanto respecto al aro

One of the principal factors that can influence the life of a bearing is the clearance. The clearance of the bearing or the internal clearance (initial clearance) represents the rating of a bearing before mounting it on a shaft or inside of the housing case. The clearance of a bearing can be intended both in a radial sense as well as an axial sense when the movement of the free ring is in the radial sense we say radial clearance while we say axial clearance if the movement is axial. The radial clearance determines the average rating of the various measurements of the total movement on a plain which is perpendicular to the axis of the bearing. Such movement is typical of one of the rings of the bearing (the other is fixed) during the rolling in various angular directions both with respect to the

rodante como también al fijo y en las diversas posiciones angulares de la serie de bolas, respecto a los aros mismos. En virtud de los diferentes coeficientes de juego requeridos los rodamientos rígidos pueden ser fabricados con diversos juegos iniciales. En general los rodamientos de bolas se fabrican con juego radial normal CN, que, en la mayoría de los casos, permite parámetros satisfactorios de funcionamiento. El juego radial se evidencia con el agregado a la sigla del rodamiento de la designación de la clase de precisión (C2, C3, C4, C5). Para los rodamientos fabricados con un juego radial del grupo normal CN no se añaden ulteriores designaciones convencionales. La vida útil de un rodamiento puede verse influenciada por diversos factores, como por ejemplo los acoplamientos de montaje, las eventuales diferencias de temperatura entre el aro interior y el aro exterior, etc. De ello se deduce que la elección del juego del rodamiento es un factor extremadamente importante, porque además de determinar la vida útil influye también en la rumorosidad, las vibraciones y la producción de calor del rodamiento. El juego del rodamiento debe garantizar su buen funcionamiento, en particular modo en el momento en el cual podrían presentarse contracciones del aro exterior o interior, de acuerdo a la aplicación. Las siguientes tablas suministran los valores de juego radial.

rotating ring and with respect to the fixed ring and the different angular positions of the series of spheres with respect to the rings themselves.

Considering the different coefficients of clearance required, the radial bearings can be constructed according to various initial groups.

As a norm, spherical bearings are constructed with a normal CN radial clearance that with common use in the majority of cases, supply satisfying functioning parameters. Radial clearance is indicated by an acronym on the bearing with the designation of the precision class (C2, C3, C4, C5), while the bearings constructed with a radial clearance corresponding to the normal group CN are not assigned an ulterior conventional designation.

The life of a bearing can be influenced by different factors accompanied by the mounting and eventual temperature differences between the internal and external ring etc...

From this we deduce that the choice of the clearance of the bearing is an extremely important factor because besides determining the length, it influences the noiselessness, the vibration, the production of heat.

The clearance, of the bearing must guarantee good functioning, in particular, at the moment in which contractions of the external or internal ring may be present depending upon the application. The following table supplies radial clearance ratings.

5.1

TIPO DE JUEGO RADIAL

TYPES OF RADIAL CLEARANCE

Juego Clearance	Significado Meaning	Condiciones operativas posibles Possible working conditions
C2	Juego radial de los rodamientos inferiores a CN Radial clearance of bearings lower than CN	Reducción rumorosidad y vibraciones Reduction of noisiness and vibrations
CN	Juego radial normal de los rodamientos Normal radial clearance of bearings	Condiciones normales Normal conditions
C3	Juego radial de los rodamientos superiores a CN Radial clearance of bearings higher than CN	Montaje con interferencias en ambos aros Assembling with interferences on both rings
C4	Juego radial de los rodamientos superior a C3 Radial clearance of bearings higher than C3	Errores de montaje, eje y aro interior calentados Assembling mistakes, shaft and inner rings heated
C5	Juego radial de los rodamientos superior a C4 Radial clearance of bearings higher than C4	Eje en caliente y asiento en frío Heated shaft and cooled housing

Rodamiento con agujero cilíndrico - *Cylindrical bore bearings*

Dimensión del agujero (d) <i>Bore dimension (d)</i>				Juego radial <i>Radial clearance</i>																			
Más de - <i>Over</i>		Hasta - <i>Up to</i>		C2				CN				C3				C4				C5			
mm	pulgadas <i>inch</i>	mm	pulgadas <i>inch</i>	mín	máx	mín	máx	mín	máx	mín	máx	mín	máx	mín	máx	mín	máx	mín	máx	mín	máx	mín	máx
2,5	0,0984	10	0,3937	0	7	0	3	2	13	1	5	8	23	3	9	14	29	6	11	20	37	8	15
10	0,3937	18	0,7087	0	9	0	4	3	18	1	7	11	25	4	10	18	33	7	13	25	45	10	18
18	0,7087	24	0,9449	0	10	0	4	5	20	2	8	13	28	5	11	20	36	8	14	28	48	11	19
24	0,9449	30	1,1811	1	11	0,4	4	5	20	2	8	13	28	5	11	23	41	9	16	30	53	12	21
30	1,1811	40	1,5748	1	11	0,4	4	6	20	2	8	15	33	6	13	28	46	11	18	40	64	16	25
40	1,5748	50	1,9685	1	11	0,4	4	6	23	2	9	18	36	7	14	30	51	12	20	45	73	18	29
50	1,9685	65	2,5591	1	15	0,4	6	8	28	3	11	23	43	9	17	38	61	15	24	55	90	22	35
65	2,5591	80	3,1496	1	15	0,4	6	10	30	4	12	25	51	10	20	46	71	18	28	65	105	26	41
80	3,1496	100	3,9370	1	18	0,4	7	12	36	5	14	30	58	12	23	53	84	21	33	75	120	30	47
100	3,9370	120	4,7244	2	20	1	8	15	41	6	16	36	66	14	26	61	97	24	38	90	140	35	55
120	4,7244	140	5,5118	2	23	1	9	18	48	7	19	41	81	16	32	71	114	28	45	105	160	41	63

Rodamiento con agujero cónico - *Conical bore bearings*

Dimensión del agujero (d) <i>Bore dimension (d)</i>				Juego radial <i>Radial clearance</i>																			
Más de - <i>Over</i>		Hasta - <i>Up to</i>		C2				CN				C3				C4							
mm	pulgadas <i>inch</i>	mm	pulgadas <i>inch</i>	mín	máx	mín	máx	mín	máx	mín	máx	mín	máx	mín	máx	mín	máx	mín	máx	mín	máx		
24	0,9449	30	1,1811	5	20	2	8	13	28	5	11	23	41	9	16	30	53	12	21				
30	1,1811	40	1,5748	6	20	2	8	15	33	6	13	28	46	11	18	40	64	16	25				
40	1,5748	50	1,9685	6	23	2	9	18	36	7	14	30	51	12	20	45	73	18	29				
50	1,9685	65	2,5591	8	28	3	11	23	43	9	17	38	61	15	24	55	90	22	35				
65	2,5591	80	3,1496	10	30	4	12	25	51	10	20	46	71	18	28	65	105	26	41				
80	3,1496	100	3,9370	12	36	5	14	30	58	12	23	53	84	21	33	75	120	30	47				
100	3,9370	120	4,7244	15	41	6	16	36	66	14	26	61	97	24	38	90	140	35	55				
120	4,7244	140	5,5118	18	48	7	19	41	81	16	32	71	114	28	45	105	160	41	63				

La función principal del proceso de lubricación es la de evitar que se pueda generar una fricción excesiva entre las bolas, los caminos de rodadura y las jaulas, reducir dentro de ciertos límites la rumorosidad de funcionamiento, garantizar a los rodamientos protección contra la corrosión y disminuir también la eventual fricción de las obturaciones. Los soportes **ISB**[®] están lubricados con grasas que mantienen sus propias características en el tiempo, en condiciones normales de funcionamiento. Cuando las condiciones de servicio lo requieran (condiciones externas desfavorables, aumento de la temperatura, aumento de los giros del rodamiento) será necesario efectuar lubricaciones adicionales, para que el rodamiento trabaje siempre en las condiciones más favorables. Las tablas expuestas a continuación muestran los valores indicativos de los intervalos de lubricación de los soportes relubricables. Se precisa que existen también otros tipos de soportes libres de mantenimiento (véase más adelante).

*The lubrication process is meant principally to avoid excessive wear between the sphere, the rolling track and the cage to reduce to certain limits the noise level of functioning, assure the protection of the bearing against corrosion and furthermore to diminish eventual wear from the seal. **ISB**[®] housings are lubricated with grease that maintains its characteristics over time during normal exercise conditions.*

When conditions require (external unfavourable conditions, increased temperature, increased rounds of the bearing), an ulterior greasing should be done in order to permit the bearing to always operate in more favourable conditions. The following table indicates what the guideline ratings are for the periods of lubrication of housings which can be lubricated again. We should note that some housings exist which do not require maintenance and this is explained as follows.

6.1
SOPORTES LIBRES DE MANTENIMIENTO
MAINTENANCE-FREE BEARING UNITS

Los soportes **ISB**[®] libres de mantenimiento constituyen unidades listas para el montaje. Los rodamientos utilizados en este tipo de soportes contienen grasa saponificada de litio de elevada calidad, que permite un funcionamiento continuo a temperaturas que pueden variar de los -30°C a los +100°C. El sistema de obturación garantiza la protección total contra eventuales agentes contaminantes (polvo, humedad, fluidos varios) y evita todo escape de la grasa. La rotación misma del eje permite la circulación de la grasa y el mantenimiento de la lubricación dentro del rodamiento por un prolongado lapso de tiempo. A continuación se enumeran las principales ventajas de los soportes libres de mantenimiento:

***ISB**[®] housings which are exempt from maintenance are units which are ready to be mounted. The bearings used in this type of housing contain a high quality type of grease made of saponified lithium which allows the functioning to continue at temperatures which vary from -30°C to +100°C. The sealing system guarantees that the bearings are perfectly protected from eventual external pollutants (dust, humidity, various fluids) and it prevents the grease from exiting. The rotation of the shaft itself permits the grease to circulate and the lubrication itself inside the bearing maintains itself for a long period. The main advantages of using these housings is that they are exempt for maintenance and are regrouped as reported below:*

- mayor resistencia a eventuales infiltraciones de agentes contaminantes externos
- ninguna dispersión de la grasa utilizada para la lubricación
- unidades compactas, gracias a la ausencia de dispositivos de lubricación
- ahorro en términos de tiempo y de costes de mantenimiento
- *increased resistance to eventual infiltration from pollutants*
- *no dispersion of grease used to lubricate*
- *compact units because there are no lubrication devices*
- *savings in terms of time and the expense of maintenance*

6.2

SOPORTES REENGRASABLES

RE-GREASEABLE BEARING UNITS

Los soportes **ISB**[®] de fundición y de acero inoxidable se pueden suministrar con un específico engrasador que permite relubricar periódicamente el rodamiento. El agujero donde está ubicado el engrasador puede provocar un debilitamiento de la estructura del soporte. De todos modos la posición de dicho agujero ha sido estudiada para reducir al mínimo este problema. En condiciones normales es preferible utilizar soportes libres de mantenimiento, si bien existen aplicaciones en las cuales resulta indispensable la utilización de soporte relubricables, como por ejemplo en los siguientes casos:

- utilización en condiciones extremadamente críticas, donde no resulta posible el empleo de ulteriores dispositivos de cierre (tapas de protección)
- utilización en máquinas que trabajan en modo intermitente y donde están presentes agentes contaminantes externos
- utilizaciones caracterizadas por una elevada rotación y donde existe la problemática de una excesiva rumorosidad
- utilización del soporte con temperaturas superiores a +140°C

En condiciones normales de funcionamiento de los soportes **ISB**[®] la cantidad de grasa presente en el rodamiento es suficiente para toda la vida útil del soporte. Si se presentan condiciones externas desfavorables, como elevadas variaciones térmicas o elevados números de giros, será indispensable evaluar atentamente estos factores, ya que los mismos pueden influenciar significativamente sobre los intervalos de lubricación.

*The **ISB**[®] housing units in the cast iron version and in the stainless steel version can be supplied with the necessary lubricator which permits periodic re-greasing of the bearings. The bore where the greaser is positioned can create a weakness in the structure of the housing, even if studies performed, the position of the bore is located in such a way as to render the effects of the above mentioned minimal. In normal conditions it is preferable to use housings which are exempt from maintenance. Even so, there are, in any case, some applications where the use of re-grease bearings is indispensable, as in the case sited below:*

- *use in extremely critical conditions, where it is not possible to use ulterior closure devices (protective covers)*
- *use on machines that work at intermittence and where external pollutant agents are present.*
- *use in cases where the number of rotations are elevated and the may be noise problems.*
- *use when temperatures are above +140° C.*

***ISB**[®] housing units used in normal conditions, contain a quality grease inside the bearing which is sufficient for all of the life of the bearing. As unfavourable external conditions such as elevated thermal variations, the number of rounds increased, are verified it will be indispensable to evaluate adequately these factors because the can notably influence the lubrication intervals.*

6.3

FRECUENCIA DE LA LUBRICACIÓN

PERIODICITY OF LUBRICATION

Los valores recogidos en la siguiente tabla se refieren a intervalos de lubricación para un funcionamiento estimado de 8 horas al día.

The ratings, indicated in the table below, are relative to the intervals of lubrication for functioning approximately 8 hours per day.

Temperatura Temperature	Condiciones de servicio- Working conditions			Rodamiento Bearing	Grasa Grease
	Normales Normal	Polvo Dust	Polvo y humedad Dust and damp		
50°C ➤ 50°C 70°C ➤ 70°C 70°C ➤ 100°C	360/720 días/days 360 días/days 180 días/days	360 días/days 120 días/days 60 días/days	120 días/days 30 días/days 15 días/days	Normal Normal	Litio Lithium
100°C ➤ 120°C 120°C ➤ 150°C	60 días/days 15 días/days	15 días/days 5 días/days	5 días/days 2 días/days	Termorresistente Heat-resistant	Calcio Calcium
150°C ➤ 180°C 180°C ➤ 200°C	7 días/days 3 días/days	2 días/days 1 día/day	1 día/day 1 día/day	Termorresistente Heat-resistant	Especial Special

Los soportes pueden ser reengrasados a través del engrasador de bola que se encuentra en la parte exterior del soporte. Se debe introducir la grasa gradualmente en el engrasador **(1)** y ésta, a través del canal **(2)** presente en la parte interna del soporte, alcanza los dos agujeros **(3)** por donde entra en el rodamiento. Es muy importante tener en cuenta las siguientes recomendaciones:

- no efectuar el engrase en el primer montaje
- no utilizar nunca aceite para la lubricación
- utilizar siempre el tipo de grasa aconsejado
- eliminar toda posible impureza presente en el engrasador
- introducir la grasa en modo lento y gradual, haciendo en lo posible girar el eje
- no introducir nunca una cantidad excesiva de grasa (podría comprometer el funcionamiento del rodamiento)
- si se ha desmontado el rodamiento, prestar mucha atención al volver a montarlo, observando que la parte más extensa del aro interior de resalte **(4)** quede del mismo lado que el engrasador; sólo en esta posición resulta posible el reengrase del soporte.

*The housings can be re-lubricated using the greaser supplied for that purpose (sphere type), which can be found on the external part of the housing. The grease is inserted gradually in the greaser **(1)** and using the small canal **(2)** which can be found in the internal part of the housing, reach two holes **(3)** which permit the entry of the grease into the bearing. We recommend that careful attention be given to the following:*

- *avoid using grease when first mounting*
- *do not ever use oil to lubricate*
- *always use the grease recommended*
- *clean the greasing tool well from eventual impurities*
- *insert the grease in a gradual and slow manner making the shaft rotate if possible*
- *never introduce excessive quantities of grease (they could compromise the functioning)*
- *if the bearing has been dismantled, give careful attention to remounting so that the prolonged part of the internal ring which sticks out **(4)** is from the same side as the greaser because this is the only position in which it is possible to re-lubricate the housing*

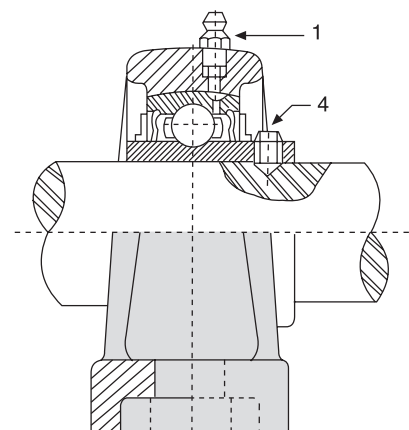
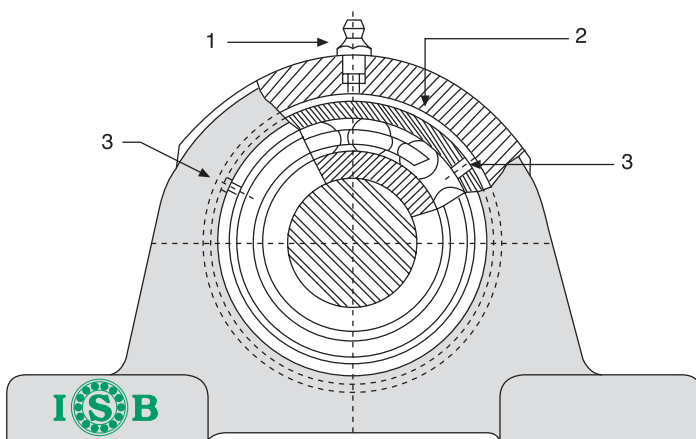

6.5

CANTIDAD DE GRASA

GREASE QUANTITY

Generalmente los rodamientos para soportes **ISB®** se llenan aproximadamente al 30-35%. Dicho porcentaje resulta adecuado para las aplicaciones más comunes. Una lubricación excesiva provocaría escapes de la grasa y un recalentamiento del rodamiento a causa de una mayor resistencia. En las lubricaciones periódicas se aconseja respetar lo más posible la cantidad de grasa indicada en la tabla expuesta a continuación. Para aplicaciones a bajas velocidades es posible aumentar la cantidad de grasa, pero nunca más allá del doble de lo indicado.

*Normally the bearings for the **ISB®** housings are filled to 30-35%, the suitable percentage for most common applications.*

If the bearings were to be filled with a larger quantity, this would provoke the grease to overflow and also with resistance that would be created there would be an overheating effect.

When lubricating periodically, it is advisable to use the quantities of grease indicated in the table below.

For low speed uses, the values in the table can even increase but not more than double the amount indicated.

Tipo de rodamiento Bearing type			Cantidad (g) Quantity (g)
UC 201	-	-	1,6
UC 202	-	-	1,6
UC 203	-	-	1,6
UC 204	-	-	1,6
UC 205	-	UK 205	1,6
UC 206	UCX 05	UK 206	3,1
UC 207	UCX 06	UK 207	4
UC 208	UCX 07	UK 208	5
UC 209	UCX 08	UK 209	5,7
UC 210	UCX 09	UK 210	6,7
UC 211	UCX 10	UK 211	8,6
UC 212	UCX 11	UK 212	11,7
UC 213	UCX 12	UK 213	13,5
UC 214	UCX 13	UK 214	16,2
UC 215	UCX 14	UK 215	18
UC 216	UCX 15	UK 216	22,5
UC 217	UCX 16	UK 217	27,5
UC 218	UCX 17	UK 218	35
-	UCX 18	-	47
-	UCX 20	-	67
-	-	-	-

Tipo de rodamiento Bearing type		Cantidad (g) Quantity (g)
UC 305	UK 305	4
UC 306	UK 306	5,4
UC 307	UK 307	7,3
UC 308	UK 308	9,5
UC 309	UK 309	11,9
UC 310	UK 310	16,1
UC 311	UK 311	21
UC 312	UK 312	26,5
UC 313	UK 313	31,5
UC 314	UK 314	40
UC 315	UK 315	47,5
UC 316	UK 316	55,5
UC 317	UK 317	65
UC 318	UK 318	76
UC 319	UK 319	91,5
UC 320	UK 320	116,5
UC 321	UK 321	135
UC 322	UK 322	164
UC 324	UK 324	196
UC 326	UK 326	242
UC 328	UK 328	288,5

6.6

ENGRASADORES

GREASE NIPPLE

La mayor parte de los soportes **ISB**® se suministran con engrasador de latón, tipo estándar (bajo demanda pueden suministrarse también engrasadores galvanizados o de acero inoxidable). Para poder efectuar el engrase es necesario utilizar la correspondiente herramienta. En caso de exigencias particulares de aplicación pueden ser suministrados otros tipos de engrasadores, como se ilustra en los siguientes diseños.

Most **ISB**® housings are furnished with the right grease nipple in brass as a standard type (upon request also zinc or stainless steel plated) In order to carry out greasing, it will be necessary to use the proper tool. Should there be necessity for a particular application it is possible to supply other types of grease nipple as can be seen in the following diagrams.



Latón - Galvanizados - Acero inoxidable
Brass - Galvanized - Stainless steel

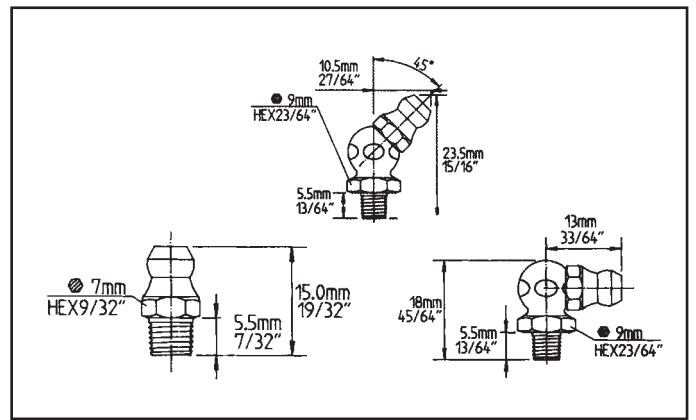

Tipo estándar - Standard type

Disponible sólo bajo demanda - Available on request

6.7

TABLA DE LOS LUBRICANTES

TABLES OF LUBRICANTS

Los lubricantes para rodamientos utilizados en los soportes ISB® deben responder a los siguientes requisitos:

- resultar estables a nivel físico y químico
- estar libres de cuerpos extraños provenientes de componentes mecánicos (abrasivos, sustancias metálicas, etc.)
- garantizar un coeficiente mínimo de fricción
- presentar una buena capacidad lubricante

La siguiente tabla ilustra los lubricantes generalmente utilizados y sus principales características.

The lubricants for bearings used in ISB® housings should respond to the following requirements:

- be stable, both on a physical as well as a chemical level
- be exempt foreign bodies originating from mechanical components (abrasives, metallic substances etc...)
- guarantee a minimum coefficient of rubbing
- have a good lubricating capacity

The following table explains which are the common lubricants used as well as their principle characteristics.

Marca y tipo Brand name	Grasa base Basic type grease	Temperatura de servicio Operating temperature	Características Characteristics
Exxon Beacon 325	Grasa sintética Synthetic grease	-55 > +120°C	Grasa genérica General grease
Chevron SRI-2	Grasa mineral Mineral grease	-35 > +180°C	Indicada a altas temperaturas con buena resistencia al agua High temperature range with good water resistance
Shell Alvania 2	Grasa mineral Mineral grease	-35 > +120°C	Prolongada vida útil Long life
DuPont Krytox 240AC (Mil-G-27617)	Grasa fluorada Fluorinate grease	-35 > +290°C	Indicada a altísimas temperaturas. No pierde sus propiedades lubricantes (elevado costo) High temperature stability with good lubricating properties and (very high price)
Shell Dolium R	Grasa de petróleo Petroleum grease	-40 > +150°C	Resistente a la corrosión y al agua Good corrosion resistance and water washout properties
KYODO SRL	Grasa sintética Synthetic grease	-40 > +150°C	Baja rumorosidad y bajas cargas Low noise and low torque applications
Mobil HP	Litio Lithium complex	-30 > +110°C	Resistente a la corrosión y a las vibraciones, indicada para velocidades moderadas Vibration, moderate speeds and good corrosion resistance

Los soportes **ISB**[®] normalmente se suministran ya montados y por lo general embalados individualmente. Prestar atención al desembalar el rodamiento de no perder posibles accesorios presentes en el paquete, como por ejemplo las llaves y los engrasadores. Los soportes **ISB**[®] son fáciles de montar. Es necesario de todos modos tener en cuenta las siguientes indicaciones para garantizar una normal vida útil de funcionamiento del soporte:

- cerciorarse de que la superficie donde se monta el soporte sea lo suficientemente rígida y plana
- evitar desalineaciones superiores a $\pm 2^\circ$ entre la superficie sobre la cual se monta el soporte y la línea axial del eje

ISB[®] bearing units are normally furnished already mounted and singularly packaged. Care should be taken while opening the package so that eventual added accessories such as keys and grease nipple are not lost.

ISB[®] bearing units are easily to mount without prior know how, it is however important to give attention to the following points in order to have a normal live span of the unit:

- *ascertain that the surface where the unit will be mounted is sufficiently rigid and flat.*
- *avoid misalignments outside of $\pm 2^\circ$ between the surface where the unit is to be mounted and the axis of the shaft.*

7.1
FIJACIÓN CON PASADORES
SETSCREWS FIXING

La fijación del rodamiento en el eje se logra enroscando dos pasadores presentes en la superficie del rodamiento mismo (fig. A). Para racionalizar dicha operación se aconseja: aplanar levemente el eje en la zona del pasador de fijación (fig. 1) o bien realizar una leve cavidad (fig. 2). En este último caso será necesario prestar mucha atención para que no se den desplazamientos axiales que puedan deformar el rodamiento. Es necesario ajustar lo más posible los pasadores se fijación, evitando así cualquier desplazamiento del aro interior sobre el eje. **Evitar de todos modos un apriete excesivo de los pasadores**, que podría provocar una deformación del aro interior y causar un deslizamiento no uniforme. Montar los pasadores de fijación siguiendo los valores indicados en las tablas que se exponen a continuación.

Si el rodamiento va a estar sometido a fuertes oscilaciones o cargas axiales es aconsejable realizar un apoyo (fig. 3) en el eje, en modo tal de fijar el aro interior con una tuerca contra dicho apoyo.

The fixing of the bearing to the shaft takes place using setscrews the are located on the surface of the bearing itself (fig. A). To realize such an operation it is advisable to do the following: flatten slightly the shaft in the zone where the setscrew will be fixed (fig. 1) or hollow out a small cavity (fig. 2). In the case of the cavity, be very careful that there are no axial movements that could deform the bearing.

The setscrews should be tightened as much as possible in such a way as to avoid movement of the ring inside the shaft.

We recommend however not to over tighten or tighten excessively the setscrews however as they could cause a deformation of the internal ring with consequent deformation of the bearing and cause non uniform running.

The setscrews will be mounted according to the values indicated on the table below. If the bearing should be subject to strong oscillations or axel loads, it is advisable to hollow out a support to the shaft in such a way as to block the internal ring with a nut against the support itself.

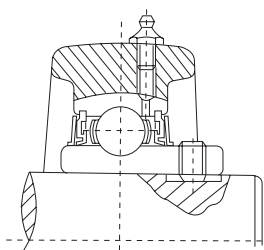

Fig. 1

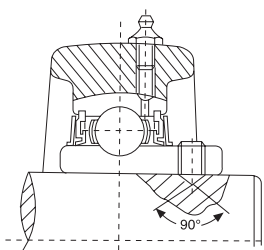

Fig. 2

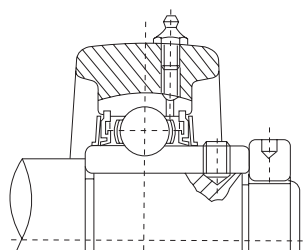

Fig. 3



Fig. A

Pares de apriete aconsejados (series métricas)

Recommended locking torque (metric series)

Tipo de rodamientos Bearings type			Sigla pasadores Designation setscrews	Par de apriete Locking torque Nm (max)
UC 201 UC 206	-	-	M 6x1	3,9
-	-	UC 305 UC 306	M 6x1	4,9
-	UCX 05	-	M 6x1	5,8
UC 207 UC 209	-	-	M 8x1	7,8
-	UCX 06 UCX 08	UC 307	M 8x1	9,8
-	UCX 09	-	M 10x1	16,6
UC 210 UC 213	-	UC 308 UC 309	M 10x1	19,6
-	UCX 10	-	M 10x1	22,5
-	UCX 11 UCX 12	-	M 10x1	24,5
UC 214 UC 218	UCX 13 UCX 16	UC 310 UC 314	M 12x1,5	28
-	UCX 17	-	M 12x1,5	34,3
-	UCX 18	UC 315 UC 316	M 14x1,5	34,3
-	UCX 20	UC 317 UC 319	M 16x1,5	53,9
-	-	UC 320 UC 324	M 18x1,5	58,8
-	-	UC 326 UC 328	M 20x1,5	78,4

Pares de apriete aconsejados (series en pulgadas)

Recommended locking torque (inches series)

Tipo de rodamientos Bearings type			Sigla pasadores Designation setscrews	Par de apriete Locking torque lbf-inch (max)
UC 201 UC 206	-	-	¼ - 28 UNF	34
-	-	UC 305 UC 306	¼ - 28 UNF	43
-	UCX 05	-	¼ - 28 UNF	52
UC 207 UC 209	-	-	5/16 - 24 UNF	69
-	UCX 06 UCX 08	UC 307	5/16 - 24 UNF	86
-	UCX 09	-	3/8 - 24 UNF	147
UC 210 UC 213	-	UC 308 UC 309	3/8 - 24 UNF	173
-	UCX 10	-	3/8 - 24 UNF	199
-	UCX 11 UCX 12	-	3/8 - 24 UNF	216
UC 214 UC 218	UCX 13 UCX 16	UC 310 UC 314	7/16 - 20 UNF	260
-	UCX 17	-	½ - 20 UNF	303
-	UCX 18	UC 315 UC 316	9/16 - 18 UNF	303
-	UCX 20	UC 317 UC 319	5/8 - 18 UNF	477
-	-	UC 320	5/8 - 18 UNF	520
-	-	-	-	-

Pares de apriete aconsejados (series métricas)
Recommended locking torque (metric series)

Tipo de rodamientos <i>Bearings type</i>	Sigla pasadores <i>Designation setscrews</i>	Par de apriete <i>Locking torque Nm (max)</i>
SB - RB 201 SB - RB 203	M 5x08	3,4
SB - RB 204 SB - RB 206	M 6x1	4,4
SB - RB 207 SB - RB 209	M 8x1	6,8

Pares de apriete aconsejados (series en pulgadas)
Recommended locking torque (inches series)

Tipo de rodamientos <i>Bearings type</i>	Sigla pasadores <i>Designation setscrews</i>	Par de apriete <i>Locking torque lbf-inch (max)</i>
SB - RB 201 SB - RB 203	10 - 32 UNF	34
SB - RB 204 SB - RB 206	¼ - 28 UNF	43
SB - RB 207 SB - RB 209	5/16 - 24 UNF	69

7.2

FIJACIÓN CON MANGUITO *TAPER ADAPTER FIXING*

Para montar el manguito de fijación, es necesario poner el soporte sobre una superficie perfectamente plana (es aconsejable no apretar completamente los bulones de fijación y luego terminar de apretarlos una vez finalizado el montaje). Introducir el manguito en modo tal que quede casi al centro del rodamiento y luego golpear suavemente con la correspondiente herramienta sobre toda la superficie lateral. Luego introducir la arandela y apretar a fondo la tuerca con la correspondiente herramienta. **Se aconseja no apretar excesivamente la tuerca** porque se podría deformar el manguito. Respetar los pares de apriete indicados. Al finalizar estas operaciones hacer girar manualmente el eje para cerciorarse que la rotación no presente dificultades.

Once ready to proceed with the mounting of the taper adapter, it is necessary to position the support on a perfectly flat surface (it's a good idea to leave the fixing bolts slightly loose and then tighten them once the operation is complete). Introduce the taper adapter with the conical part nearly at the centre of the bearing and with a tool, hit the entire lateral surface of the bolt lightly. Proceed to insert the washer and tighten completely the ferrule/ring with the proper key.

Attention: over tightening the ferrule could cause deformations therefore, stay within the values indicated below. At the end of the operation mentioned above, try to manually rotate the shaft and verify that it rotates with ease.

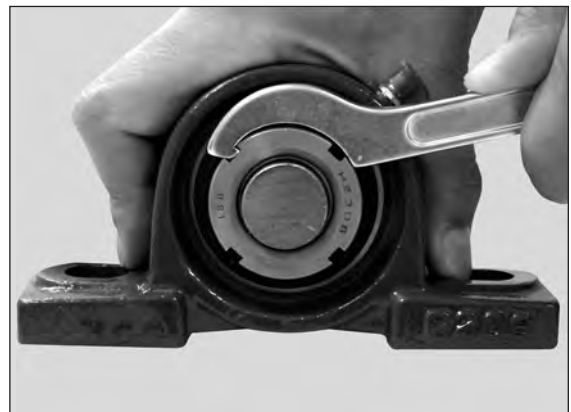
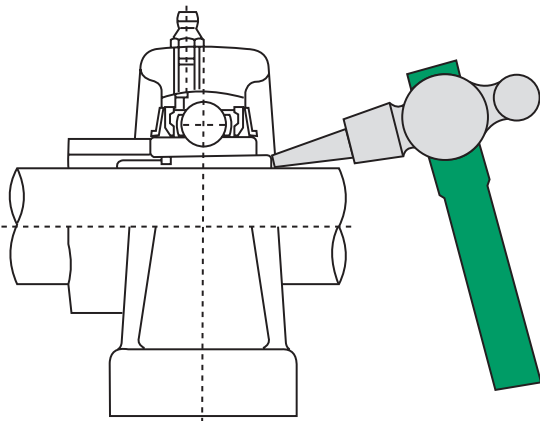

Pares de apriete aconsejados (series métricas)

Recommended locking torque (metric series)

Tipo de rodamientos <i>Bearings type</i>	Manguito de fijación <i>Taper adapter</i>	Par de apriete - Locking torque	
		Kg - cm	Nm (max)
UK 205	H 205	254	25
UK 206	H 206	305	30
UK 207	H 207	407	40
UK 208	H 208	509	50
UK 209	H 209	612	60
UK 210	H 210	764	75
UK 211	H 211	1019	100
UK 212	H 212	1325	130
UK 213	H 213	1529	150
UK 215	H 215	1732	170
UK 216	H 216	2038	200
UK 217	H 217	2344	230
UK 218	H 218	2752	270

7.3

FIJACIÓN CON ANILLO DE EXCÉNTRICO DE FIJACIÓN

ECCENTRIC COLLAR LOCKING FIXING

Otro posible sistema de fijación del rodamiento y el eje es mediante la utilización de un anillo excéntrico de fijación. En este caso la conexión entre el eje y el aro interior se logrará ajustando el anillo excéntrico en el sentido de rotación del eje. Cuando se adopta este sistema de montaje es importante realizar en modo correcto las siguientes operaciones: verificar que la superficie donde se instalará el soporte resulte adecuada para la correspondiente aplicación; verificar que el extremo del eje no presente rebavas y que el tornillo de fijación del anillo excéntrico sobresalga del lado del eje; cerciorarse que el soporte quede bien fijado sobre la superficie y que no exista la posibilidad de cargas axiales excesivas; introducir el anillo excéntrico haciéndolo girar en el sentido de rotación y golpearlo con la correspondiente herramienta para lograr su fijación. Al finalizar estas operaciones ajustar el tornillo de fijación presente en el collar, respetando los valores indicados en las tablas expuestas a continuación. Este sistema de fijación no es aconsejable para aplicaciones en las cuales el eje puede cambiar el sentido de rotación.

Another system that can be used to fix the bearing and the shaft is to use the eccentric collar locking system.

In this case the shaft and the internal ring actually linked by tightening the eccentric ring in the rotation direction of the shaft.

When mounting the eccentric collar locking system support, be sure to correctly perform the task; ascertain that the surface where it will be installed is fit for this application; verify that the edge of the shaft has no metal burr and that the blocking screws of the eccentric ring does not protrude out of the shaft; make sure that the support is securely fastened to the surface and that there is no possibility for excessive axial loads.

Insert the eccentric ring by turning, in the rotation direction, and with the proper tool, strike it so as to fix the eccentric ring.

At the end of this operation, tighten the blocking screw present on the collar staying within the limits indicated on the table below. This fixing system is not particularly indicated for applications in which the shafts can rotate in different directions.

Pares de apriete aconsejados (series métricas)
Recommended locking torque (metric series)

Tipo de rodamientos <i>Bearings type</i>			Sigla pasadores <i>Designation setscrews</i>	Par de apriete <i>Locking torque Nm (max)</i>
HC 204 HC 205	-	SA 201 SA 205	M 6x1	7,8
HC 206 HC 210	HC 303 HC 307	SA 206 SA 211	M 8x1	9,8
HC 211 HC 215	HC 308 HC 312	SA 212	M 10x1	29,4
-	HC 313 HC 314	-	M12x1,5	34,3
-	HC 315 HC 317	-	M 16x1,5	53,9
-	HC 318 HC 320	-	M 20x1,5	78,4

Pares de apriete aconsejados (series en pulgadas)
Recommended locking torque (inches series)

Tipo de rodamientos <i>Bearings type</i>			Sigla pasadores <i>Designation setscrews</i>	Par de apriete <i>Locking torque lbf-inch (max)</i>
HC 204 HC 205	-	SA 201 SA 205	¼ - 28 UNF	69
HC 206 HC 210	HC 303 HC 307	SA 206	5/16 - 24 UNF	86
HC 211 HC 215	HC 308 HC 312	SA 212	3/8 - 24 UNF	260
-	HC 313 HC 314	-	½ - 20 UNF	350
-	HC 315 HC 317	-	5/8 - 18 UNF	520
-	HC 318 HC 320	-	¾ - 16 UNF	700

7.4

MOVIMIENTO AXIAL DEBIDO A LA EXPANSIÓN O LA CONTRACCIÓN AXIAL MOVEMENT DUE TO EXPANSION AND SHRINKAGE

Sucede a menudo que en algunas aplicaciones particulares el eje se pueda expandir o contraer y que por lo tanto el rodamiento se pueda mover.

El eje de la rueda de un camión por ejemplo (cubo), debe moverse en dirección axial al límite: cuando se utiliza el eje a elevadas temperaturas la expansión térmica hace aumentar el grosor y la longitud del eje.

Si el montaje de todos los rodamientos en el eje fuera fijo se presentaría una carga axial extraordinaria sobre los mismos y también, a causa de la expansión térmica, podría producirse la rotura de los rodamientos.

Por esta razón, cuando existe posibilidad de expansión o contracción del eje, es necesario utilizar de un lado un soporte fijo y del otro un soporte móvil.

It often happens that in the presence of some particular working conditions, the shaft may expand or shrink and therefore the bearings may move.

The shaft of the wheels of a truck for example, should be moved in the axial direction to the limit: when the shaft is used at high temperatures, thermal expansion takes place and the shaft becomes wider and longer.

If the bearings are all attached to the shaft the bearing will be have an extraordinary axial load and could even break due to the thermal expansion.

This is why, in the presence of an expanding or shrinking shaft, fixed support on one side or a mobile one from the other should be used.

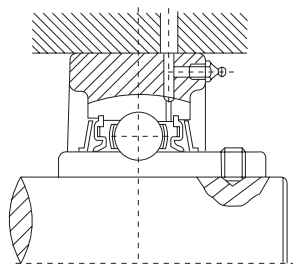

Fig. 1

Fig.1) Como se muestra, es aconsejable utilizar el tipo de soporte de cartucho y rodamiento con diámetro exterior cilíndrico, del mismo modo que con los rodamientos normales. Cuando se utilizan soportes de cartucho, es necesario prestar atención de no causar una deformación al insertarlos. El cuerpo de la estructura realizado en el modo indicado está preparado para su utilización con altas temperaturas.

Fig.2) De todas maneras la llave está mecanizada en el eje y generalmente en lugar de los pasadores de fijación se utiliza un tornillo de cabeza hexagonal. De esta manera se logra la regulación del movimiento axial causado por la expansión o la contracción del eje.

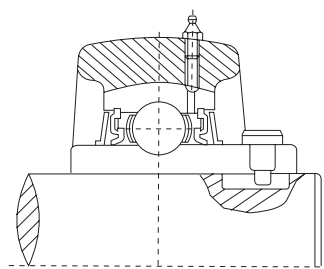

Fig. 2

Fig.1) As shown it is desirable to use a cartridge type bearing with a cylindrical outer diameter in the same manner as with ordinary bearings. When using cartridge type housings, be careful not to cause a deformation at the time of insertion. The complete housing with the above shown structure is prepared for use at high temperatures.

Fig.2) The key is machined on the shaft and a dog point hexagon hollow setscrew is generally used in place of the setscrew. Axial movement due to shaft expansion and shrinkage is in this way regulated.

7.5

DESMONTAJE DEL SOPORTE

DISASSEMBLY OF BEARING UNIT

Si por cualquier razón se hace necesario sustituir el soporte, es necesario realizar las mismas operaciones del montaje en sentido contrario. Es importante prestar mucha atención a los siguientes aspectos:

- si el soporte ha sido fijado con pasadores de fijación, es importante desenroscarlos completamente, para evitar que en el momento del desmontaje los pasadores puedan marcar el eje.
- si el soporte ha sido utilizado con manguito de fijación, es necesario levantar la lengüeta de la arandela y desenroscar levemente la arandela; a continuación apoyando un anillo, golpear con la herramienta correspondiente sobre toda la superficie de la tuerca, hasta que resulte imposible extraer el manguito. Prestar mucha atención de no dañar las roscas.

If for any reason, it becomes necessary to substitute the housing, the same operation as was done while mounting must be carried out, but in reverse. Give careful attention to the following aspects:

- If the housing had been fixed with setscrews, it is important to unscrew them completely to keep them from sliding against the shaft while dismantling.
- If the taper adapter has been used to fix the housing, lift the lip of the washer and unscrew slightly the lock nut then while supporting the ring, strike with the proper tool on the surface of the lock nut until the taper adapter can be extracted. Be very careful not to damage the threading.

7.6

SUSTITUCIÓN DEL RODAMIENTO

BEARING REPLACEMENT

Si por cualquier razón se hace necesario sustituir el rodamiento presente dentro del soporte, esto no implica que se deba sustituir también el cuerpo del soporte. Para efectuar esta operación es necesario que los tornillos de fijación estén bien apretados, para no interferir en las operaciones de sustitución. Utilizar un tubo o una herramienta similar e introducirlo dentro del agujero del rodamiento. Hacer girar el rodamiento aproximadamente 90° en modo tal de extraerlo de las guías presentes dentro de la fundición del soporte. A continuación se deberá efectuar la operación inversa para introducir el nuevo rodamiento.

If for any reason it becomes necessary to substitute the internal bearing of the housing, this does not mean that the housing must also be substituted. To do such an operation the blockage screws are well fixed so as not to interfere with the substitution operation. Using a tube or a similar tool and inserting it inside the bore in the bearing and rotating the bearing about 90° in such a way as to extract it from the guide hollowed out inside the casting of the housing; after which proceed inversely to insert the new bearing.

Dureza ROCKWELL <i>Hardness</i>	Dureza VICKERS <i>Hardness</i>	Dureza BRINNEL <i>Hardness</i>		Dureza ROCKWELL <i>Hardness</i>		Dureza SHORE <i>Hardness</i>
		Escales C <i>Scale C</i>	Bola Estándar <i>Ball</i>	Bola ¹⁾ <i>Ball¹⁾</i>	Escales A <i>Scale A</i>	
68	940	-	-	85,6	-	97
67	900	-	-	85,0	-	95
66	865	-	-	84,5	-	92
65	832	-	739	83,9	-	91
64	800	-	722	83,4	-	88
63	772	-	705	82,8	-	87
62	746	-	688	82,3	-	85
61	720	-	670	81,8	-	83
60	697	-	654	81,2	-	81
59	674	-	634	80,7	-	80
58	653	-	615	80,1	-	78
57	633	-	595	79,6	-	76
56	613	-	577	79,0	-	75
55	595	-	560	78,5	-	74
54	577	-	543	78,0	-	72
53	560	-	525	77,4	-	71
52	544	500	512	76,8	-	69
51	528	487	496	76,3	-	68
50	513	475	481	75,9	-	67
49	498	464	469	75,2	-	66
48	484	451	455	74,7	-	64
47	471	442	443	74,1	-	63
46	458	432	432	73,6	-	62
45	446	421	421	73,1	-	60
44	434	409	409	72,5	-	58
43	423	400	400	72,0	-	57
42	412	390	390	71,5	-	56
41	402	381	381	70,9	-	55
40	392	371	371	70,4	-	54
39	382	362	362	69,9	-	52
38	372	353	353	69,4	-	51
37	363	344	344	68,9	-	50
36	354	336	336	68,4	(109,0)	49
35	345	327	327	67,9	(108,5)	48
34	336	319	319	67,4	(108,00)	47
33	327	311	311	66,8	(107,5)	46
32	318	301	301	66,3	(107,0)	44
31	310	294	294	65,8	(106,0)	43
30	302	286	286	65,3	(105,5)	42
29	294	279	279	64,7	(104,5)	41
28	286	271	271	64,3	(104,0)	41
27	279	264	264	63,8	(103,0)	40
26	272	258	258	63,8	(102,5)	38
25	266	253	253	62,8	(101,5)	38
24	260	247	247	62,4	(101,0)	37
23	254	243	243	62,0	100,0	36
22	248	237	237	61,5	99,0	35
21	243	231	231	61,0	98,5	35
20	238	226	226	60,5	97,8	34
(18)	230	219	219	-	96,7	33
(16)	222	212	212	-	95,5	32
(14)	213	203	203	-	93,9	31
(12)	204	194	194	-	92,3	29
(10)	196	187	187	-	90,7	28
(8)	188	179	179	-	89,5	27
(6)	180	171	171	-	87,1	26
(4)	173	165	165	-	85,5	25
(2)	166	158	158	-	83,5	24
(0)	160	152	152	-	81,7	24

¹⁾ al carbono de tungsteno - tungsten carbon material's

Tipología Type	EUROPA - EUROPE				ASIA - ASIA	
	ISB® Italia - Italy	INA/FAG Alemania - Germany	RHP Reino Unido United Kingdom	SKF Suecia - Sweden	ASAHI Japón - Japan	FYH Japón - Japan
Soportes de pie Pillar blocks	UCP 2.., UKP 2.., HCP 2..	RASE, RASES, PASE	NP	SY, SYP, SYJ..TF	UCP, UKP 200	UCP, UKP, NAP 200
	UCLP 2..	-	SL	SYH-X	-	SL 200
	UCP X..	-	MP	-	UCP X00	UCP X00
	UCPH 2.., UKPH 2..	-	-	-	UCPH 200	UCPH 200
	UCPA 2.., UKPA 2.. UP..	SHE -	- -	- -	SYF -	UCPA 200 UP 00
Soportes de brida Flange units	UCF 2.., UKF 2.., HCF 2..	RCJ, RCJS, PCF	SF, SLF	FY, FYR, FY-X	UCF, UKF 200	UCF 200 SLF 200
	UCF X..	-	MSF	-	UCF X00	UCF X00
	UCFC 2.., UKFC 2.., HCF 2..	-	-	FYC	UCFC, UKFC 200	UCFC 200
	UCFC X..	-	MFC	-	UCFC X00	UCFC X00
	UCFL 2.., UKFL 2.. HCFL 2..	RCJT, RCJTS, PCFT	SFT	FYTB	UCFL 200	UCFL 200
	UCFL X..	-	MSFT	-	UCFL X00	UCFL X00
	UFL..	-	-	-	UFL 00	-
	SAFD 2.. - SBFD 2..	FLCTE / FLCTEY	-	-	-	-
	SALF 2.. - SBLF 2..	-	-	-	-	ALF-BLF 2
UCFA 2.., UKFA 2..	SFT	-	-	UCFA 200	UCFA 200	
UCFB 2.., UKFB 2..	-	-	-	UCFK 200	UCFB 200	
Soportes tensores Take-up units	UCT 2.., UKT 2.., HCT 2..	PTUE, RTUES	-	-	UCT 200	UCT 200
	UCT X..	-	-	-	UCT X00	UCT X00
Placa tensora Stretch-skid	UCT..	-	-	-	WA	UCTH
Soportes de cartucho Cylindrical cartridge units	UCC 2.., UKC 2.., HCC 2..	-	-	TU	UCC 200	UCC 200
	UCC X..	-	-	-	UCC X00	UCC X00
Soportes colgantes Hanger units	UCECH 2.., UKECH 2..	-	SCHB	-	UCECH 200	UCHA 200
Soportes de chapa estampada Pressed steel bearing units	BPP..	PB	LPB	SP	BPP	SBPP 200 F
	BP..	RA, RR	SLFE	F	BPF	SBPF 200
	BPFL..	RAT, RRT	SLFL	FT	BPFL	SBPFL 200
	BPFT..	RATR, RRTR	-	-	BPFT	-
Soportes para agricultura Agricultural units	ST	-	-	-	-	-
Soportes de pie partidos Bearing housing	SNG 500	-	-	SNH 500	-	-
	SNG 600	-	-	SNH 600	-	-
	SN 500	-	-	-	-	-
	SN 200	-	-	SNH 200	-	-
	SN 300	-	-	SNH 300	-	-
	SD 3000 SD 3100	- -	- -	- SD 3100	- -	- -
Soportes de plástico Plastic bearing units	UCP 2..	PASE, RASEY	-	-	-	-
	UCF 2..	PCJ, RCJY	-	-	-	-
	UCFL 2..	PCJT, RCJTY	-	-	-	-
	UCECH 2..	-	-	-	-	-
	UCPA 2..	-	-	-	-	-
	UCFB 2..	-	-	-	-	-
Rodamientos para soportes Bearings for units	UC2..	KRRB	1000 G	YAR	UC 200	UC 200
	HC 2..	GE..KRRB	-	YEL 200	UG 200	NA 200
	UCX..	-	-	-	UCX 00	UCX 00
	UC 3..	-	-	YEL 300	UC 300	UC 300
	UK 2..	GSE..KRRB	1000 G	YSA 200	UK 200	UK 200
	UK 3..	-	-	YSA 300	UK 300	UK 300
	SER 2..	-	-	-	SER 200	ER 200
	SA 2..	RAE..NPPB	12..EC	YET 200	SA 200	SA 200
	SB 2..	AY..NPPB	-	YAT 200	SB 200	SB 200
	RB 2..	-	-	-	-	RB 200
	SC 2.. U0..	2..NPPB -	- -	- -	- -	SC 200 -

La tabla anterior puede ser utilizada como referencia general de intercambiabilidad de los soportes y rodamientos **ISB®** con soportes de otras marcas. Cuando se utilizan productos de otras marcas verificar siempre atentamente que sus dimensiones correspondan a las de los productos **ISB®**. En esta tabla no se han citado los rodamientos de la serie pesada. De todos modos los mismos están disponibles para las series: UCP - UCF - UCFS - UCFL - UCT

ASIA - ASIA				U.S.A. - U.S.A.		
KOYO Japón - Japan	NACHI Japón - Japan	NSK Japón - Japan	NTN Japón - Japan	FAFNR Estados Unidos de América - U.S.A.	LINK-BELT Estados Unidos de América - U.S.A.	SEAL-MASTER Estados Unidos de América - U.S.A.
UCP, UKP 200, GAP 1100B	UCP, UKP+H, UGP, BP 200	UCP, UKP, EWP 200	UCP, UK UEL 200	RAS, LAS	P3-Y200N	NP
SLP 200	UCLP, FGAK 200	UCPLL, EWPLL 200	UCPL 200	RAK, LAK	PL3-Y200N	S-500-M
UCP X00	UCP, UKP+H X00	UCP X00	UCP X00	RAKH, LAKH	-	MP
-	-	UCPH 200	UCPH 200	-	-	-
UCPA 200, UKPA 200	UCPA 200	UCPA 200	UCUP 200	-	-	-
-	-	UBLP 200	UP 00	-	-	-
UCF 200 GFF 1100	UCF, UKF+H, UGF, BF, UCLF 200	UCF, EWFH 200	UCF 200	RCJ, LCJ	F3-Y200N	SF
UCF X00	UCF, UKF+H X00	UCF X00	UCF X00	RCJO, LCJO	-	MSF
UCFC 200	UCFC, UKFC+H, UGFC, BCF 200	UCFC 200	UCFC 200	-	-	-
UCFC X00	UCF, UKFC+H X00	UCFC X00	UCFC X00	RFC	FC3-Y200N	MFC
UCFL 200 UCFL 1100	UCFL, UKFL+H, UGFL, BFL, UCFT 200	UCFL, EWFLH 200	UCFL 200	FCJT, LCJT	FX3-Y200N	SFT
UCFL X00	UCFL, UKFL+H X00	UCFL X00	UCFL X00	-	-	MSFT
-	-	UBLF 200	UFL 00	-	-	-
-	-	-	ASFD 2	-	-	-
-	-	-	-	-	-	-
UCFA 200 UKFA 200	-	UCFA 200	UCFA 200	-	-	-
UCBF 200	UCFK 200	UCFK 200	UCFH 200	-	-	-
UCT 200	UCT, UKT+H, UGT, BT 200	UCT 200	UCT 200	-	-	-
UCT X00	UCT, UKT+H X00	UCT X00	UCT X00	-	-	-
LV-HT	-	WB	UCT	-	-	-
UCC 200	UCC, UKC+H, UGC, BC 200	UCC 200	UCC 200	-	-	-
UCC X00	UCC, UKC+H X00	UCC X00	UCC X00	-	-	-
SCHB 200	ECECH 200	UCEH 200	UCHB 200	-	-	SEHB
SP	BPP	UBPP 200	ASPP 200	PB	-	SSP
PF	BPF	UBPF 200	ASPF 200	RE, RR	MSC1	SSF
PTF	BPFL	UBPFL 200	ASPFL 200	RAT, RRT	MST	SSFT
PTFR	BPFT	UBPFT 200	-	RATR, RRTR	MSTR	TSSF
-	-	-	-	-	-	-
-	-	-	-	-	-	-
-	-	-	-	-	-	-
-	-	-	-	-	-	-
-	-	-	-	-	-	-
-	-	-	-	-	-	-
-	-	-	-	-	-	-
-	-	-	-	-	-	-
-	-	-	-	-	-	-
-	-	-	-	-	-	-
-	-	-	-	-	-	-
-	-	-	-	-	-	-
-	-	-	-	-	-	-
-	-	-	-	-	-	-
-	-	-	-	-	-	-
-	-	-	-	-	-	-
-	-	-	-	-	-	-
-	-	-	-	-	-	-
UC 200	UC (UCW) 200	UC 200	UC 200	GC1100KRRB	YG 200 N	2-00
-	-	EW 200	UEL 200	G1100KRBB	-	-
UCX 00	UCX 00	UCX 00	UCX 00	GN-KRRB	U300D	3-00
UC 300	UC 300	UC 300	UC 300	-	-	-
UK 200	UK 200	UK 200	UK 200	G-KLLB	YG 200 N	2-00
UK 300	UK 300	UK 300	UK 300	-	-	-
-	SER 200	-	UCS 200	GC-KRRG-2	-	ER
-	KH 200 AE	EN 200	AEL 200	RA..RRB	-	L-00
PB	B	UB 200	AS 200	YA..RRB	-	-
-	-	UR 200	-	-	-	-
CB	-	CS 2.. DDU	CS 2.. LLU	-	-	-
-	-	-	-	-	-	-

The above table should be used as a cross reference for **ISB®** and other manufacturers of self-aligning bearing units. Please note that some dimensions of the **ISB®** brand may differ slightly from those of other manufacturers. Heavier duty Pillow Blocks have not been included in this cross reference table. Sizes available are: UCP - UCF - UCFS - UCFL - UCT.

Soporte Housing	Tipo - Type					
	UC2.. UC3.. UCX..	UK2.. UK3.. UKX..	HC2..	SA2..	SB-RB2..	U0
P	UCP2.. - UCP3.. UCLP2.. - UCPX..	UKP2.. - UKP3.. UKPX..	HCP2..	SAP	SBP	-
F	UCF2.. - UCF3.. UCF53.. - UCFX..	UKF2.. - UKF3.. UKFX..	HCF2..	SAF	SBF	-
FC	UCFC2.. - UCFCX..	UKFC2.. - UKFCX..	HCFC2..	SAFC	SBFC	-
FL	UCFL2.. - UCFL3.. UCFLX..	UKFL2.. - UKFL3.. UKFLX..	HCFL2..	SAFL	SBFL	-
T	UCT2.. - UCT3.. UCTX..	UKT2.. - UKT3.. UKTX..	HCT2..	SAT	SBT	-
C	UCC2.. - UCC3.. UCCX..	UKC2.. - UKC3.. UKCX..	HCC2..	SAC	SBC	-
PH	UCPH2..	UKPH2..	HCPH2..	SAPH	SBPH	-
PA	UCPA2..	UKPA2..	HCPA2..	SAPA	SBPA	-
FA	UCFA2..	UKFA2..	HCFA2..	SAFA	SBFA	-
FB	UCFB2..	UKFB2..	HCFB2..	SAFB	SBFB	-
ECH	UCECH2..	UKECH2..	HCECH2..	SAECH	SBECH	-
LP Aluminio Aluminium	-	-	HCLP2..	SALP	-	UP
LF Aluminio Aluminium	-	-	HCLF2..	SALF2..	-	UFL
FD	-	-	HCFD2..	SAFD2..	SBFD2..	-
LF	-	-	HCLF2..	SALF2..	SBLF2..	-
ST	Soportes agrícolas (bajo demanda disponibles medidas en pulgadas) - Agricultural bearing units (inches size are available under request)					
PP	BPP..	-	-	BPP-SA2..	BPP-SB2..	-
PF	BPF..	-	-	BPF-SA2..	BPF-SB2..	-
PFL	BPFL..	-	-	BPFL-SA2..	BPFL-SB2..	-
FT	BPFT..	-	-	BPFT-SA2..	BPFT-SB2..	-
SNG SN-SD	Soportes de pie partidos - Bearing Housings					
P Plástico Plastic	UCP2..	con rodamiento UC inox y de plástico - with plastic or stainless steel UC bearing				
F Plástico Plastic	UCF2..	con rodamiento UC inox y de plástico - with plastic or stainless steel UC bearing				
FC Plástico Plastic	UCFC2..	con rodamiento UC inox y de plástico - with plastic or stainless steel UC bearing				
FL Plástico Plastic	UCFL2..	con rodamiento UC inox y de plástico - with plastic or stainless steel UC bearing				
T Plástico Plastic	UCT2..	con rodamiento UC inox y de plástico - with plastic or stainless steel UC bearing				
ECH Plástico Plastic	UCECH2..	con rodamiento UC inox y de plástico - with plastic or stainless steel UC bearing				
PA Plástico Plastic	UCPA2..	con rodamiento UC inox y de plástico - with plastic or stainless steel UC bearing				
FB Plástico Plastic	UCFB2..	con rodamiento UC inox y de plástico - with plastic or stainless steel UC bearing				

Tipo - Type

 Página
Page

						Soportes Bearing units	44
				 Stretch-skid for UCT			
						Soportes de chapa Pressed steel bearing units	96
						Rodamientos Bearings	102
				 Manguitos de fijación Adapter sleeves			
						Soportes de pie partidos Plummer blocks	114
						Soportes de brida Housings	135
						Soportes de plástico Plastic bearing units	136
						Soportes para husillos de bolas Supports of ball screws	149

Los soportes **ISB** no sólo pueden ser utilizados con temperaturas normales sino también en aplicaciones con elevadas temperaturas.

En los soportes **ISB** para Alta Temperatura (**HT**) se utiliza una tipología especial de obturación y de grasa, especialmente estudiadas para resistir a más de 100°C, como se indica en la tabla que sigue a continuación.

En las aplicaciones a elevadas temperaturas es necesario tener en cuenta que los soportes presentan una disminución de la carga máxima admisible y un incremento del juego radial, respecto a las normales condiciones de utilización.

El estándar de referencia para el juego radial de los rodamientos montados en estos soportes es C4, tanto para los agujeros cilíndricos como también para los cónicos.

En caso de elevado diferencial de temperatura entre el aro interior y el aro exterior del rodamiento es necesario prever juegos radiales especiales.

ISB bearing units may be used not only in normal temperature conditions, but also in high temperature applications.

ISB bearing units for High Temperature (HT) use suitable kind of rubber seal and the grease for specific operating temperature as shown in the table reported below.

For heat resistance application, it must be taken in consideration the decrease of load rating of the bearings and a larger-than-normal radial internal clearance.

Standard radial internal clearances for High Temperature applications are C4 for both cylindrical and tapered bore bearings.

When temperature gap between the inner and the outer ring of the bearing is extremely large, suitable radial internal clearance must be determined.

Intervalos de temperaturas de funcionamiento

Range of operating temperature

Aplicación <i>Application</i>	Temperatura <i>Temperature</i>	Grasa <i>Grease</i>	Obturación de caucho <i>Rubber seal</i>	Color blindaje <i>Colour of slinger</i>
Estándar <i>Standard</i>	-15 ➤ +100°C	A base de litio <i>Lithium-Base Grease 2</i>	NBR	Negro <i>Black</i>
Alta temperatura <i>High Temperature</i>	Hasta +200 °C <i>Up to +200 °C</i>	Egols-8604	Silicona <i>Silicon rubber</i>	Rojo <i>Red</i>

SOPORTES

BEARING UNITS



SOPORTES DE CHAPA

PRESSED STEEL BEARING UNITS



UCP2 Serie normal - Standard duty

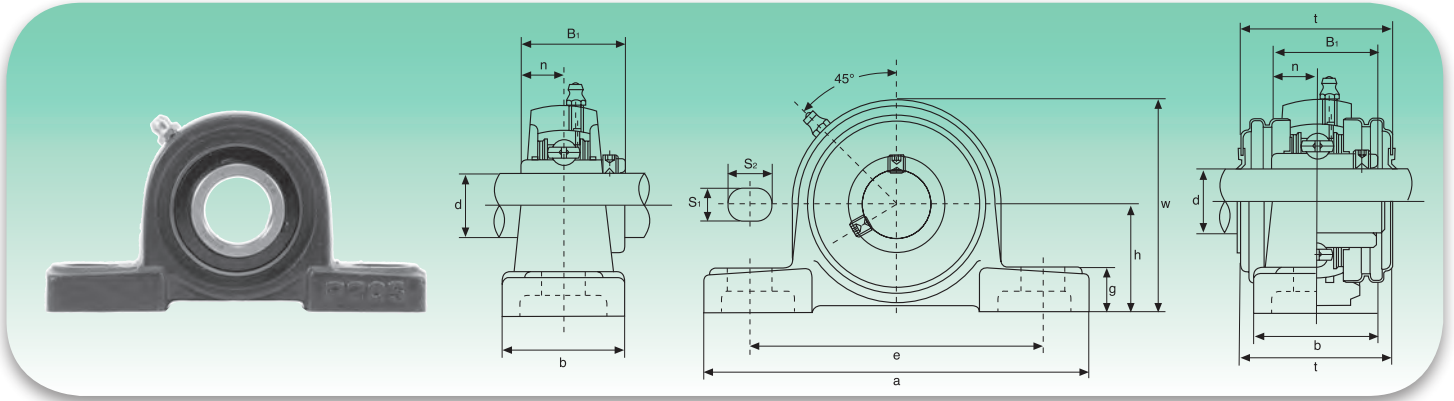

Tipo Type	Dimensiones - Dimensions												Bul. fj. Bolt Size	Coeficientes de carga (N) Load ratings (N)		Rodamiento Bearing	Soporte Housing	Peso Weight	
	d	h	a	e	b	S ₁	S ₂	g	w	t	B ₁	n		Dinámica C Dynamic C	Estática C ₀ Static C ₀				kg
	mm/inch													mm/inch					
UCP201	12	30,2	127	95	38	13	19	14	62	44,5	31	12,7	M10	12160	6318	UC201	P203	0,69	
UCP201-8	3/4	13/16	5	3 3/4	1 1/2	1/2	3/4	9/16	27/16	1 3/4	1,2205	0,500	3/8						
UCP202	15	30,2	127	95	38	13	19	14	62	44,5	31	12,7	M10	12160	6318	UC202	P203	0,69	
UCP202-9	9/16	13/16	5	3 3/4	1 1/2	1/2	3/4	9/16	27/16	1 3/4	1,2205	0,500	3/8						
UCP202-10	5/8	13/16	5	3 3/4	1 1/2	1/2	3/4	9/16	27/16	1 3/4	1,2205	0,500	3/8			UC202-10		0,69	
UCP203	17	30,2	127	95	38	13	19	14	62	44,5	31	12,7	M10	12160	6318	UC203	P203	0,68	
UCP203-11	11/16	13/16	5	3 3/4	1 1/2	1/2	3/4	9/16	27/16	1 3/4	1,2205	0,500	3/8						
UCP204	20	33,3	127	95	38	13	19	14	65	44,5	31	12,7	M10	12160	6318	UC204	P204	0,66	
UCP204-12	3/4	15/16	5	3 3/4	1 1/2	1/2	3/4	9/16	29/16	1 3/4	1,2205	0,500	3/8						
UCP205	25	36,5	140	105	38	13	19	15	71	48	34,1	14,3	M10	13300	7457	UC205	P205	0,81	
UCP205-13	13/16																		
UCP205-14	7/8	17/16	5 1/2	41/8	1 1/2	1/2	3/4	19/32	225/32	157/64	1,3425	0,563	3/8						
UCP205-15	15/16																		
UCP205-16	1																		
UCP206	30	42,9	165	121	48	17	20	17	84	53	38,1	15,9	M14	18525	10735	UC206	P206	1,24	
UCP206-17	11/16																		
UCP206-18	11/8	111/16	6 1/2	4 3/4	17/8	43/64	25/32	21/32	35/16	25/64	1,5000	0,626	1/2						
UCP206-19	13/16																		
UCP206-20	1 1/4																		
UCP207	35	47,6	167	127	48	17	20	18	93	59,5	42,9	17,5	M14	24415	14630	UC207	P207	1,58	
UCP207-20	1 1/4																		
UCP207-21	15/16	17/8	69/16	5	17/8	43/64	25/32	45/64	321/32	211/32	1,6890	0,689	1/2						
UCP207-22	13/8																		
UCP207-23	17/16																		
UCP208	40	49,2	184	137	54	17	20	18	100	69	49,2	19	M14	27645	16910	UC208	P208	1,89	
UCP208-24	1 1/2	115/16	7 1/4	513/32	21/8	43/64	25/32	45/64	315/16	223/32	1,9370	0,748	1/2						
UCP208-25	19/16																		
UCP209	45	54,0	190	146	54	17	20	20	106	69	49,2	19	M14	32395	20235	UC209	P209	2,14	
UCP209-26	15/8																		
UCP209-27	111/16	21/8	715/32	5 3/4	21/8	43/64	25/32	25/32	411/64	223/32	1,9370	0,748	1/2						
UCP209-28	1 3/4																		
UCP210	50	57,2	206	159	60	20	23	21	113	74,5	51,6	19	M16	33345	22135	UC210	P210	2,66	
UCP210-29	113/16																		
UCP210-30	17/8	2 1/4	81/8	6 1/4	23/8	25/32	29/32	53/64	429/64	215/16	2,0315	0,748	5/8						
UCP210-31	115/16																		
UCP210-32	2																		
UCP211	55	63,5	219	171	60	20	23	23	125	76	55,6	22,2	M16	41230	27930	UC211	P211	3,31	
UCP211-32	2																		
UCP211-33	21/16	2 1/2	85/8	647/64	23/8	25/32	29/32	29/32	459/64	3	2,1890	0,874	5/8						
UCP211-34	21/8																		
UCP211-35	23/16																		
UCP212	60	69,8	241	184	70	20	23	25	138	89	65,1	25,4	M16	49780	34390	UC212	P212	4,90	
UCP212-36	2 1/4																		
UCP212-37	25/16	2 3/4	9 1/2	7 1/4	234	25/32	29/32	63/64	57/16	3 1/2	2,5630	1,000	5/8						
UCP212-38	23/8																		
UCP212-39	27/16																		
UCP213	65	76,2	265	203	70	25	28	27	150	89	65,1	25,4	M20	54340	38095	UC213	P213	5,15	
UCP213-40	2 1/2	3	107/16	8	2 3/4	63/64	13/32	11/16	529/32	3 1/2	2,5630	1,000	3/4						
UCP213-41	29/16																		
UCP214	70	79,4	266	210	72	25	28	27	156	-	74,6	30,2	M20	59090	41895	UC214	P214	6,20	
UCP214-42	25/8																		
UCP214-43	211/16	31/8	1015/32	817/64	227/32	63/64	13/32	11/16	69/64	-	2,9370	1,189	3/4						
UCP214-44	2 3/4																		
UCP215	75	82,6	275	217	74	25	28	28	162	-	77,8	33,3	M20	64030	45885	UC215	P215	7,16	
UCP215-45	213/16																		
UCP215-46	27/8	3 1/4	1053/64	835/64	229/32	63/64	13/32	13/32	63/8	-	3,0630	1,311	3/4						
UCP215-47	215/16																		
UCP215-48	3																		
UCP216	80	88,9	292	232	78	25	28	30	174	-	82,6	33,3	M20	69065	50350	UC216	P216	8,10	
UCP216-49	31/16																		
UCP216-50	31/8	3 1/2	11 1/2	91/8	31/16	63/64	13/32	13/16	627/32	-	3,2520	1,311	3/4						
UCP216-51	33/16																		
UCP217	85	95,2	310	247	83	25	28	32	185	-	85,7	34,1	M20	79800	58805	UC217	P217	9,81	
UCP217-52	3 3/4																		
UCP217-53	35/16	3 3/4	1213/64	923/32	317/64	63/64	13/32	1 1/4	79/32	-	3,3740	1,343	3/4						
UCP217-55	37/16																		
UCP218	90	101,6	327	262	88	27	30	33	198	-	96	39,7	M22	91295	67925	UC218	P218	11,96	
UCP218-56	3 1/2	4	127/8	105/16	315/32	11/16	13/16	119/64	751/64	-	3,7795	1,5630	7/8						

Disponibile en acero inox. Soporte: AISI 304 - Rodamiento: AISI 440C - Available stainless steel Housing: AISI 304 - Bearing: AISI 440C
 Disponible bajo demanda con rodamiento SA (SAP.) - Available under request with SA bearing (SAP.)

HCP2 Serie normal - Standard duty

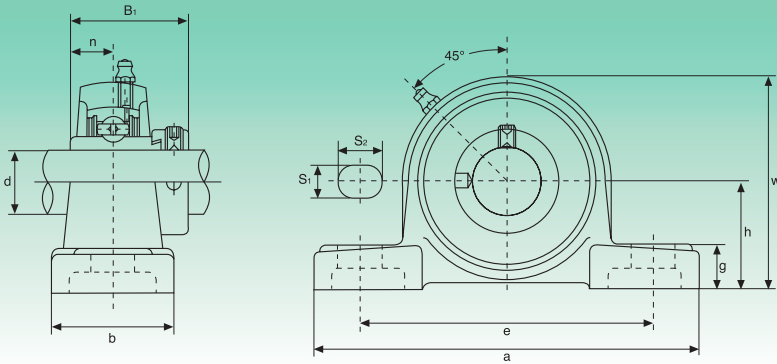

Tipo Type	Dimensiones - Dimensions											Bul. fj. Bolt Size	Coeficientes de carga (N) Load ratings (N)		Rodamiento Bearing	Soporte Housing	Peso Weight	
	d	h	a	e	b	S ₁	S ₂	g	w	B ₁	n		Dinámica C Dynamic C	Estática C ₀ Static C ₀				kg
	mm/inch												mm/inch					
HCP204	20	33,3	127	95	38	13	19	14	65	43,7	17,1	M10	12160	6318	HC204	P204	0,73	
HCP204-12	1¼	15/16	5	3¾	1½	½	¾	9/16	29/16	1,720	0,673	3/8			0,73			
HCP205	25	36,5	140	105	38	13	19	15	71	44,4	17,5	M10	13300	7457	HC205	P205	0,88	
HCP205-13	13/16	17/16	5½	41/8	1½	½	¾	19/32	225/32	1,748	0,689	3/8			0,93			
HCP205-14	7/8														0,92			
HCP205-15	15/16														0,90			
HCP205-16	1														0,88			
HCP206	30														42,9		165	121
HCP206-17	11/16	111/16	6½	4¾	17/8	43/64	25/32	21/32	35/16	1,906	0,720	½	1,42					
HCP206-18	11/8												1,39					
HCP206-19	13/16												1,37					
HCP206-20	1¼												1,34					
HCP207	35	47,6	167	127	48	17	20	18	93	51,1	18,8	M14	24415	14630	HC207	P207	1,70	
HCP207-20	1¼	17/8	69/16	5	17/8	43/64	25/32	45/64	321/32	2,012	0,740	½			1,77			
HCP207-21	15/16														1,73			
HCP207-22	13/8														1,70			
HCP207-23	17/16														1,67			
HCP208	40	49,2	184	137	54	17	20	18	100	56,3	21,4	M14	27645	16910	HC208	P208	2,04	
HCP208-24	1½	115/16	7¼	513/32	21/8	43/64	25/32	45/64	315/16	2,217	0,843	½			2,09			
HCP208-25	19/16														2,05			
HCP209	45	54,0	190	146	54	17	20	20	106	56,3	21,4	M14	32395	20235	HC209	P209	2,31	
HCP209-26	15/8	111/16	715/32	5¾	21/8	43/64	25/32	25/32	411/64	2,217	0,843	½			2,42			
HCP209-27	111/16														2,37			
HCP209-28	1¾														2,33			
HCP210	50	57,2	206	159	60	20	23	21	113	62,7	24,6	M16	33345	22135	HC210	P210	2,85	
HCP210-29	113/16	2¼	81/8	6¾	23/8	25/32	29/32	53/64	429/64	2,469	0,969	5/8			3,00			
HCP210-30	17/8														2,94			
HCP210-31	115/16														2,88			
HCP210-32	2														2,82			
HCP211	55	63,5	219	171	60	20	23	23	125	71,4	27,8	M16	41230	27930	HC211	P211	3,52	
HCP211-32	2	2½	85/8	647/64	23/8	25/32	29/32	29/32	459/64	2,811	1,094	5/8			3,72			
HCP211-33	21/16														3,64			
HCP211-34	21/8														3,57			
HCP211-35	23/16														3,49			
HCP212	60	69,8	241	184	70	20	23	25	138	77,8	31	M16	49780	34390	HC212	P212	5,24	
HCP212-36	2¼	2¾	9½	7¼	234	25/32	29/32	63/64	57/16	3,063	1,220	5/8			5,40			
HCP212-37	25/16														5,31			
HCP212-38	23/8														5,26			
HCP212-39	27/16														5,13			
HCP213	65	76,2	265	203	70	25	28	27	150	85,7	34,1	M20	54340	38095	HC213	P213	5,71	
HCP213-40	2½	3	107/16	8	2¾	63/64	13/32	11/16	529/32	3,374	1,343	¾			5,81			
HCP213-41	29/16														5,70			
HCP214	70	79,4	266	210	72	25	28	27	156	85,7	34,1	M20	59090	41895	HC214	P214	6,70	
HCP214-42	25/8	31/8	1015/32	817/64	227/32	63/64	13/32	11/16	69/64	3,374	1,343	¾			6,94			
HCP214-43	211/16														6,83			
HCP214-44	2¾														6,71			
HCP215	75	82,6	275	217	74	25	28	28	162	92,1	37,3	M20	64030	45885	HC215	P215	7,79	
HCP215-45	213/16	3¾	1053/64	835/64	229/32	63/64	13/32	13/32	63/8	3,626	1,426	¾			8,09			
HCP215-46	27/8														7,96			
HCP215-47	215/16														7,83			
HCP215-48	3														7,69			

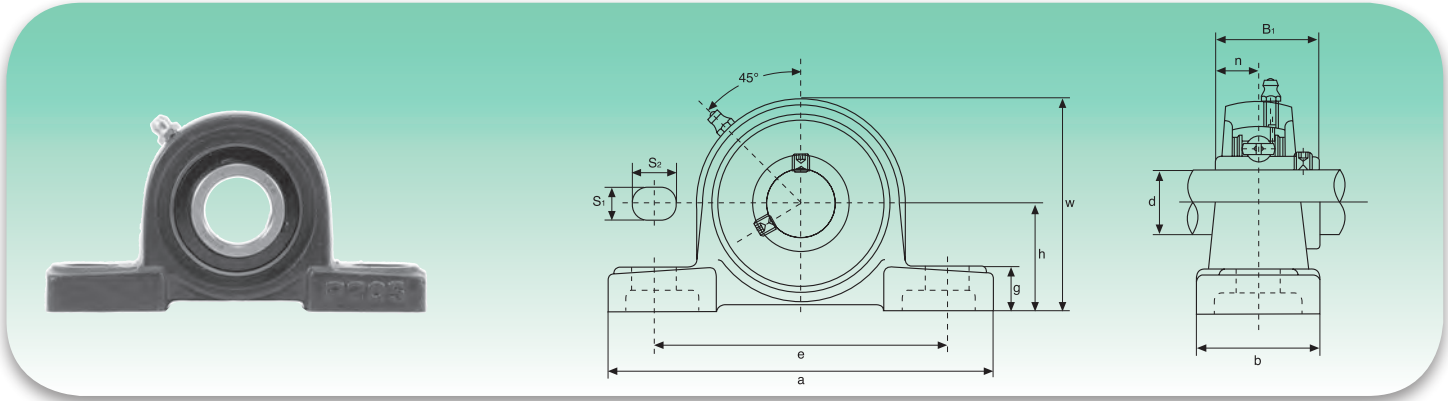

Tipo Type	Dimensiones - Dimensions											Bul. fj. Bolt Size	Coeficientes de carga (N) Load ratings (N)		Rodamiento Bearing	Soporte Housing	Peso Weight	
	d	h	a	e	b	S ₁	S ₂	g	w	B ₁	n		Dinámica C Dynamic C	Estática C ₀ Static C ₀				kg
	mm/inch												mm/inch					
UCLP201 UCLP201-8	12 ¾	31,75 1¼	127 5	95 3¾	38 1½	13 ½	16 5/8	14 9/16	64 233/64	31 1,2205	12,7 0,500	M10 3/8	12160	6318	UC201 UC201-8	LP204	0,69 0,69	
UCLP202 UCLP202-9 UCLP202-10	15 9/16 5/8	31,75 1¼	127 5	95 3¾	38 1½	13 ½	16 5/8	14 9/16	64 233/64	31 1,2205	12,7 0,500	M10 3/8	12160	6318	UC202 UC202-9 UC202-10	LP204	0,69 0,69 0,69	
UCLP203 UCP203-11	17 11/16	31,75 1¼	127 5	95 3¾	38 1½	13 ½	16 5/8	14 9/16	64 233/64	31 1,2205	12,7 0,500	M10 3/8	12160	6318	UC203 UC203-11	LP204	0,68 0,67	
UCLP204 UCLP204-12	20 ¾	31,75 1¼	127 5	95 3¾	38 1½	13 ½	16 5/8	14 9/16	64 233/64	31 1,2205	12,7 0,500	M10 3/8	12160	6318	UC204 UC204-12	LP204	0,66 0,66	
UCLP205 UCLP205-13 UCLP205-14 UCLP205-15 UCLP205-16	25 13/16 7/8 15/16 1	33,34 15/16	140 5½	105 41/8	38 1½	13 ½	16 5/8	15 19/32	68 243/64	34,1 1,3425	14,3 0,563	M10 3/8	13300	7457	UC205 UC205-13 UC205-14 UC205-15 UC205-16	LP205	0,81 0,85 0,83 0,82 0,81	
UCLP206 UCLP206-17 UCLP206-18 UCLP206-19 UCLP206-20	30 11/16 11/8 13/16 1¼	39,69 19/16	165 6½	121 4¾	48 17/8	17 43/64	20 25/32	17 21/32	80 35/32	38,1 1,5000	15,9 0,626	M14 ½	18525	10735	UC206 UC206-17 UC206-18 UC206-19 UC206-20	LP206	1,24 1,27 1,26 1,24 1,23	
UCLP207 UCLP207-20 UCLP207-21 UCLP207-22 UCLP207-23	35 1¼ 15/16 13/8 17/16	46,04 113/16	167 69/16	127 5	48 17/8	17 43/64	20 25/32	18 45/64	91 337/64	42,9 1,6890	17,5 0,689	M14 ½	24415	14630	UC207 UC207-20 UC207-21 UC207-22 UC207-23	LP207	1,58 1,64 1,61 1,58 1,55	
UCLP208 UCLP208-24 UCLP208-25	40 1½ 19/16	49,2 115/16	184 7¼	137 513/32	54 21/8	17 43/64	20 25/32	18 45/64	100 315/16	49,2 1,9370	19 0,748	M14 ½	27645	16910	UC208 UC208-24 UC208-25	LP208	1,89 1,93 1,90	
UCLP209 UCLP209-26 UCLP209-27 UCLP209-28	45 15/8 111/16 1¾	52,39 21/16	190 715/32	146 5¾	54 21/8	17 43/64	20 25/32	20 25/32	104 43/32	49,2 1,9370	19 0,748	M14 ½	32395	20235	UC209 UC209-26 UC209-27 UC209-28	LP209	2,14 2,24 2,20 2,14	
UCLP210 UCLP210-29 UCLP210-30 UCLP210-31 UCLP210-32	50 113/16 17/8 115/16 2	55,56 23/16	206 81/8	159 6¾	60 23/8	20 25/32	23 29/32	21 53/64	112 413/32	51,6 2,0315	19 0,748	M16 5/8	33345	22135	UC210 UC210-29 UC210-30 UC210-31 UC210-32	LP210	2,66 2,78 2,73 2,68 2,64	
UCLP211 UCLP211-32 UCLP211-33 UCLP211-34 UCLP211-35	55 2 21/16 21/8 23/16	61,91 27/16	219 85/8	171 647/64	60 23/8	20 25/32	23 29/32	23 29/32	124 47/8	55,6 2,1890	22,2 0,874	M16 5/8	41230	27930	UC211 UC211-32 UC211-33 UC211-34 UC211-35	LP211	3,31 3,46 3,40 3,35 3,29	
UCLP212 UCLP212-36 UCLP212-37 UCLP212-38 UCLP212-39	60 2¼ 25/16 23/8 27/16	68,26 211/16	241 9½	184 7¼	70 234	20 25/32	23 29/32	25 63/64	136 523/64	65,1 2,5630	25,4 1,000	M16 5/8	49780	34390	UC212 UC212-36 UC212-37 UC212-38 UC212-39	LP212	4,90 5,03 4,95 4,88 4,81	

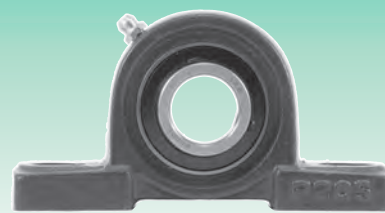
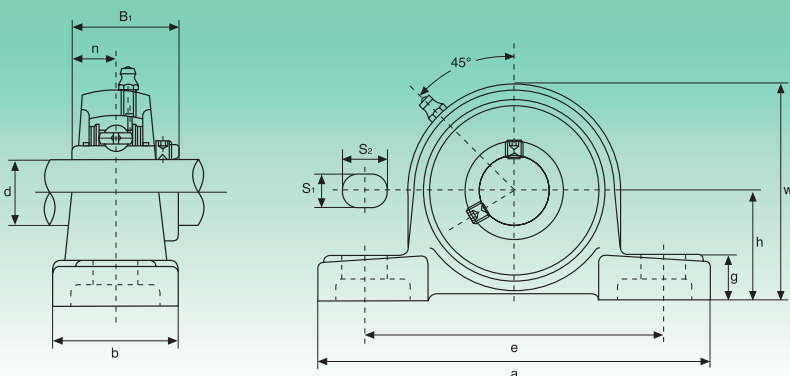

Tipo Type	Dimensiones - Dimensions											Bul. fj. Bolt Size	Coeficientes de carga (N) Load ratings (N)		Rodamiento Bearing	Soporte Housing	Peso Weight			
	d	h	a	e	b	S ₁	S ₂	g	w	B ₁	n		Dinámica C Dynamic C	Estática C ₀ Static C ₀				kg		
	mm/inch												mm/inch							
UCP305	25	45	175	132	45	17	20	15	85	38	15	M14			UC305 UC305-13 UC305-14 UC305-15 UC305-16	P305	1,4			
UCP305-13	13/16																			
UCP305-14	7/8	149/64	67/8	53/16	125/32	43/64	25/32	19/32	311/32	1,4961	0,591	1/2	20140	10355						
UCP305-15	15/16																			
UCP305-16	1																			
UCP306	30	50	180	140	50	17	20	18	95	43	17	M14			UC306 UC306-17 UC306-18 UC306-19	P306	1,8			
UCP306-17	11/16																			
UCP306-18	11/8	131/32	73/32	5 1/2	131/32	43/64	25/32	23/32	3 3/4	1,6929	0,669	1/2	25365	14250						
UCP306-19	13/16																			
UCP307	35	56	210	160	56	17	25	20	106	48	19	M14			UC307 UC307-20 UC307-21 UC307-22 UC307-23	P307	2,8			
UCP307-20	1 1/4																			
UCP307-21	15/16	113/64	89/32	65/16	213/64	43/64	31/32	25/32	43/16	1,8898	1,748	1/2	31730	18335						
UCP307-22	13/8																			
UCP307-23	17/16																			
UCP308	40	60	220	170	60	17	27	22	116	52	19	M14			UC308 UC308-24 UC308-25	P308	3,0			
UCP308-24	1 1/2																			
UCP308-25	19/16	223/64	821/32	611/16	23/8	43/64	111/16	7/8	49/16	2,0472	0,748	1/2	38665	22800						
UCP309	45	67	245	190	67	20	30	24	129	57	22	M16						UC309 UC309-26 UC309-27 UC309-28	P309	4,1
UCP309-26	15/8																			
UCP309-27	11 1/16	241/64	921/32	715/32	25/8	25/32	13/16	15/16	53/32	2,2441	0,866	5/8	46455	28025						
UCP309-28	1 3/4																			
UCP310	50	75	275	212	75	20	35	27	143	61	22	M16			UC310 UC310-29 UC310-30 UC310-31	P310	5,8			
UCP310-29	113/16																			
UCP310-30	17/8	261/64	1013/16	811/32	215/16	25/32	13/8	11/16	55/8	2,4016	0,866	5/8	58900	36385						
UCP310-31	115/16																			
UCP311	55	80	310	236	80	20	38	30	154	66	25	M16			UC311 UC311-32 UC311-33 UC311-34 UC311-35	P311	7,4			
UCP311-32	2																			
UCP311-33	21/16	35/32	127/32	99/32	35/32	25/32	1 1/2	13/16	61/16	2,5984	0,984	5/8	68020	42750						
UCP311-34	21/8																			
UCP311-35	23/16																			
UCP312	60	85	330	250	85	25	38	32	165	71	26	M20			UC312 UC312-36 UC312-37 UC312-38 UC312-39	P312	9,4			
UCP312-36	2 1/4																			
UCP312-37	25/16	311/32	13	917/32	311/32	31/32	1 1/2	1 1/4	6 1/2	2,7953	1,024	3/4	77805	49590						
UCP312-38	23/8																			
UCP312-39	27/16																			
UCP313	65	90	340	260	90	25	38	33	176	75	30	M20			UC313 UC313-40 UC313-41	P313	10			
UCP313-40	2 1/2																			
UCP313-41	29/16	335/64	133/8	10 1/4	317/32	31/32	1 1/2	15/16	615/16	2,9528	1,181	3/4	88065	56905						
UCP314	70	95	360	280	90	27	40	35	187	78	33	M22						UC314 UC314-42 UC314-43 UC314-44	P314	12
UCP314-42	25/8																			
UCP314-43	21 1/16	347/64	143/16	111/32	317/32	11/16	19/16	13/8	73/8	3,0708	1,299	7/8	98800	64790						
UCP314-44	2 3/4																			
UCP315	75	100	380	290	100	27	40	35	198	82	32	M22			UC315 UC315-45 UC315-46 UC315-47 UC315-48	P315	14			
UCP315-45	216/8																			
UCP315-46	27/8	315/16	1431/32	1113/32	315/16	11/16	19/16	13/8	725/32	3,2283	1,260	7/8	107350	73340						
UCP315-47	215/16																			
UCP315-48	3																			
UCP316	80	106	400	300	110	27	40	40	210	86	34	M22			UC316 UC316-49 UC316-50 UC316-51	P316	18			
UCP316-49	31/16																			
UCP316-50	31/8	411/64	15 3/4	1113/16	411/32	11/16	19/16	19/16	89/32	3,3858	1,339	7/8	111850	82365						
UCP316-51	33/16																			
UCP317	85	112	420	320	110	33	45	40	220	96	40	M27			UC317 UC317-52 UC317-53 UC317-55	P317	20			
UCP317-52	3 3/4																			
UCP317-53	35/16	413/32	1617/32	1219/32	411/32	15/16	125/32	19/16	821/32	3,7795	1,575	1	126350	91960						
UCP317-55	37/16																			
UCP318	90	118	430	330	110	33	45	45	235	96	40	M27			UC318 UC318-55 UC318-56	P318	24			
UCP318-55	37/16																			
UCP318-56	3 1/2	441/64	1615/16	13	411/32	15/16	125/32	125/32	9 1/4	3,7795	1,575	1	135850	101650						
UCP319	95	125	470	360	120	36	50	45	250	103	41	M30						UC319 UC319-58 UC319-59 UC319-60	P319	29
UCP319-58	35/8																			
UCP319-59	31 1/16	459/64	18 1/2	143/16	423/32	113/32	131/32	125/32	927/32	4,0551	1,614	11/8	145350	113050						
UCP319-60	3 3/4																			
UCP320	100	140	490	380	120	36	50	50	275	108	42	M30			UC320 UC320-64	P320	35			
UCP320-64	4	533/64	199/32	1431/32	423/32	113/32	131/32	131/32	1013/16	4,2520	1,654	11/8	164350	133950						
UCP321	105	140	490	380	120	36	50	56	283	112	44	M33						UC321 UC322 UC324 UC326 UC328	P321	35
UCP322	110	150	520	400	140	40	55	61	303	117	46	M33								
UCP324	120	160	570	450	140	40	55	71	323	126	51	M33								
UCP326	130	180	600	480	140	40	55	81	363	135	54	M33								
UCP328	140	200	620	500	140	40	55	81	403	145	59	M33								

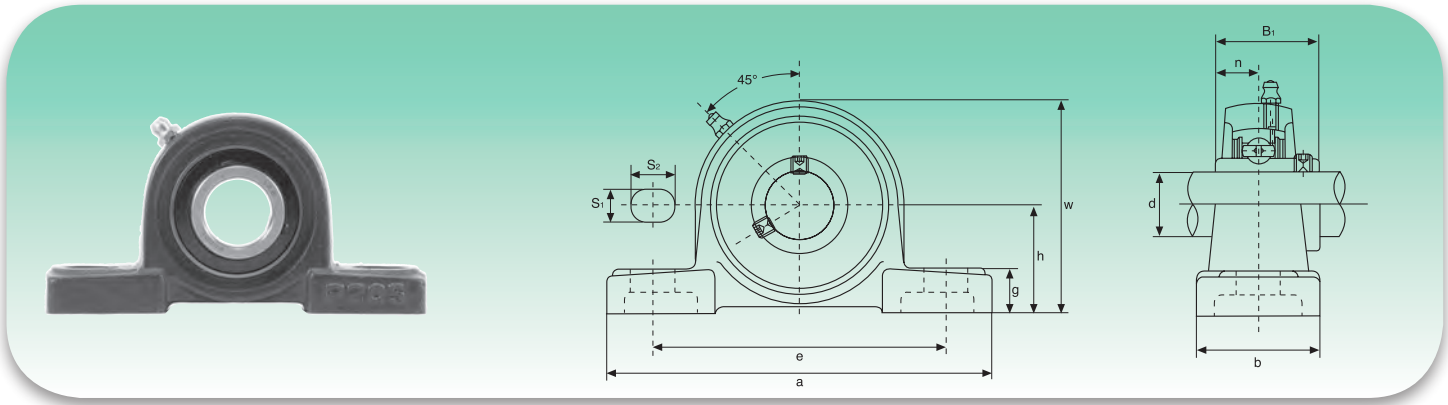

Tipo Type	Dimensiones - Dimensions											Bul. fj. Bolt Size	Coeficientes de carga (N) Load ratings (N)		Rodamiento Bearing	Soporte Housing	Peso Weight	
	d	h	a	e	b	S ₁	S ₂	g	w	B ₁	n		Dinámica C Dynamic C	Estática C ₀ Static C ₀				kg
	mm/inch												mm/inch					
UCPX05 UCPX05-13 UCPX05-14 UCPX05-15 UCPX05-16	25 13/16 7/8 15/16 1	44,4 1 3/4	159 6 1/4	119 4 11/16	51 2	17 43/64	20 25/32	18 23/32	85 3 11/32	38,1 1,5000	15,9 0,626	M14 1/2	18525	10735	UCX05 UCX05-13 UCX05-14 UCX05-15 UCX05-16	PX05	1,5	
UCPX06 UCPX06-17 UCPX06-18 UCPX06-19 UCPX06-20	30 1 1/16 1 1/8 1 3/16 1 1/4	47,6 1 7/8	175 6 7/8	127 5	57 2 1/4	17 43/64	20 25/32	20 25/32	93 3 31/32	42,9 1,6890	17,5 0,689	M14 1/2	24415	14630	UCX06 UCX06-17 UCX06-18 UCX06-19 UCX06-20	PX06	2,0	
UCPX07 UCPX07-21 UCPX07-22 UCPX07-23	35 1 5/16 1 3/8 1 7/16	54,0 2 1/8	203 8	144 5 21/32	57 2 1/4	17 43/64	20 25/32	21 13/16	105 4 1/8	49,2 1,9370	19 0,748	M14 1/2	27645	16910	UCX07 UCX07-21 UCX07-22 UCX07-23	PX07	2,6	
UCPX08 UCPX08-24 UCPX08-25	40 1 1/2 1 9/16	58,7 2 5/16	222 8 3/4	156 6 5/32	67 2 5/8	20 25/32	23 29/32	26 11/32	111 4 3/8	49,2 1,9370	19 0,748	M16 5/8	32395	20235	UCX08 UCX08-24 UCX08-25	PX08	3,3	
UCPX09 UCPX09-26 UCPX09-27 UCPX09-28 UCPX09-29	45 1 5/8 1 11/16 1 3/4 1 13/16	58,7 2 5/16	222 8 3/4	156 6 5/32	67 2 5/8	20 25/32	23 29/32	26 11/32	116 4 9/16	51,6 2,0315	19 0,748	M16 5/8	33345	22135	UCX09 UCX09-26 UCX09-27 UCX09-28 UCX09-29	PX09	3,3	
UCPX10 UCPX10-30 UCPX10-31 UCPX10-32	50 1 7/8 1 11/16 2	63,5 2 1/2	241 9 1/2	171 6 47/64	73 2 7/8	20 25/32	23 29/32	27 11/16	126 4 31/32	55,6 2,1890	22,2 0,874	M16 5/8	41230	27930	UCX10 UCX10-30 UCX10-31 UCX10-32	PX10	4,3	
UCPX11 UCPX11-33 UCPX11-34 UCPX11-35 UCPX11-36 UCPX11-37	55 2 1/16 2 1/8 2 3/16 2 1/4 2 5/16	69,8 2 3/4	260 10 1/4	184 7 1/4	79 3 1/8	25 31/32	28 13/32	30 13/16	137 5 13/32	65,1 2,5630	25,4 1,000	M20 3/4	49780	34390	UCX11 UCX11-33 UCX11-34 UCX11-35 UCX11-36 UCX11-37	PX11	5,7	
UCPX12 UCPX12-38 UCPX12-39	60 2 3/8 2 7/16	76,2 3	286 11 1/4	203 8	83 3 9/32	25 31/32	28 13/32	33 15/16	151 5 15/16	65,1 2,5630	25,4 1,000	M20 3/4	54340	38095	UCX12 UCX12-38 UCX12-39	PX12	7,3	
UCPX13 UCPX13-40 UCPX13-41	65 2 1/2 2 9/16	76,2 3	286 11 1/4	203 8	83 3 9/32	25 63/64	28 13/32	33 15/16	154 6 1/16	74,6 2,9370	30,2 1,189	M20 3/4	59090	41895	UCX13 UCX13-40 UCX13-41	PX13	7,6	
UCPX14 UCPX14-42 UCPX14-43 UCPX14-44	70 2 5/8 2 11/16 2 3/4	88,9 3 1/2	330 13	229 9 1/32	89 3 1/2	27 11/16	30 13/16	35 13/8	170 6 11/16	77,8 3,0630	33,3 1,311	M22 7/8	64030	45885	UCX14 UCX14-42 UCX14-43 UCX14-44	PX14	9,9	
UCPX15 UCPX15-45 UCPX15-46 UCPX15-47 UCPX15-48	75 2 13/16 2 7/8 2 15/16 3	88,9 3 1/2	330 13	229 9 1/32	89 3 1/2	27 11/16	30 13/16	35 13/8	175 6 7/8	82,6 3,2520	33,3 1,311	M22 7/8	69065	50350	UCX15 UCX15-45 UCX15-46 UCX15-47 UCX15-48	PX15	11	
UCPX16 UCPX16-49 UCPX16-50 UCPX16-51 UCPX16-52	80 3 1/16 3 1/8 3 3/16 3 3/4	101,6 4	381 15	283 11 5/32	102 4 1/32	27 11/16	30 13/16	40 1 9/16	194 7 5/8	85,7 3,3740	34,1 1,343	M22 7/8	79800	58805	UCX16 UCX16-49 UCX16-50 UCX16-51 UCX16-52	PX16	15	
UCPX17 UCPX17-53 UCPX17-55	85 3 5/16 3 7/16	101,6 4	381 15	283 11 5/32	102 4 1/32	27 11/16	30 13/16	40 1 9/16	200 7 7/8	96 3,7795	39,7 1,563	M22 7/8	91295	67925	UCX17 UCX17-53 UCX17-55	PX17	16	
UCPX18 UCPX18-56 UCPX18-57	90 3 7/16 3 3/2	101,6 4	381 15	283 11 5/32	111 4 3/8	27 11/16	30 13/16	40 1 9/16	206 8 1/8	104 4,0945	42,9 1,689	M22 7/8	103550	77805	UCX18 UCX18-56 UCX18-57	PX18	17	
UCPX20 UCPX20-58 UCPX20-59 UCPX20-60 UCPX20-61	100 3 13/16 3 7/8 3 15/16 4	127 5	432 17	337 13 9/32	121 4 3/4	33 15/16	36 113/32	45 1 25/32	244 9 19/32	117,5 4,6260	49,2 1,937	M27 1	126350	99750	UCX20 UCX20-58 UCX20-59 UCX20-60 UCX20-61	PX20	30	

UKP2 Serie normal - Standard duty

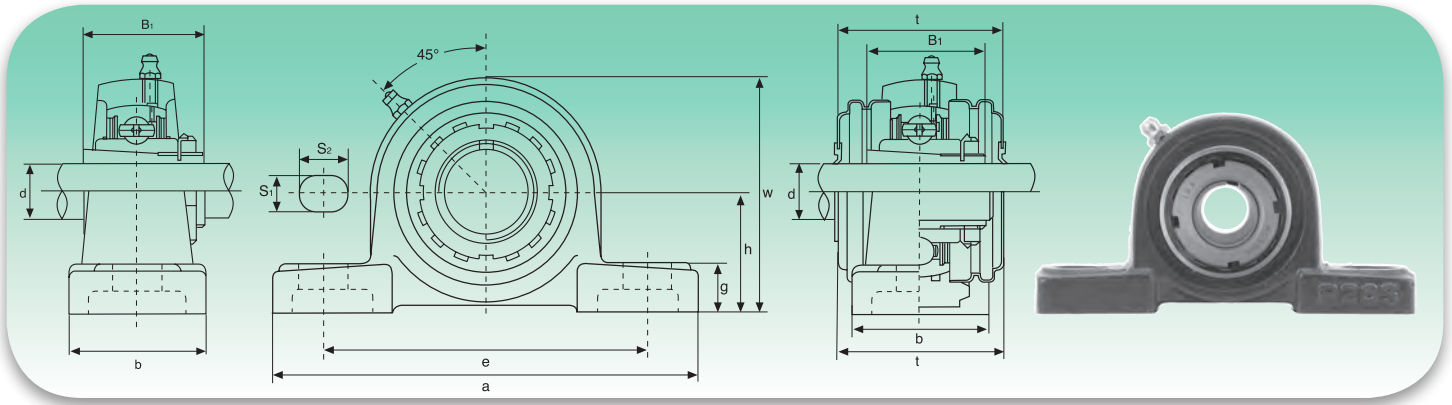

Tipo Type	Dimensiones - Dimensions											Bul. fj. Bolt Size	Coeficientes de carga (N) Load ratings (N)		Rodamiento Bearing	Soporte Housing	Peso Weight	
	d	h	a	e	b	S ₁	S ₂	g	w	t	B ₁		Dinámica C Dynamic C	Estática C ₀ Static C ₀				kg
	mm/inch												mm/inch					
UKP205+H2305	20	36,5	140	105	38	13	19	15	71	48	35	M10	13300	7457	UK205+H2305	P205	0,86	
UKP205+HE2305	¾	17/16	5½	41/8	1½	½	¾	19/32	225/32	157/64	1,378	3/8			UK205+HE2305			
UKP206+H2306	25	42,9	165	121	48	17	20	17	84	53	38	M14	18525	10735	UK206+H2306	P206	1,28	
UKP206+HS2306	7/8	111/16	6½	4¾	17/8	43/64	25/32	43/64	35/16	25/64	1,496	½			UK206+HS2306			
UKP206+HE2306	1														UK206+HE2306			
UKP207+H2307	30	47,6	167	127	48	17	20	18	93	59,5	43	M14	24415	14630	UK207+H2307	P207	1,67	
UKP207+HS2307	11/8	17/8	69/16	5	17/8	43/64	25/32	45/64	321/32	211/32	1,693	½			UK207+HS2307			
UKP208+H2308	35	49,2	184	137	54	17	20	18	100	69	46	M14	27645	16910	UK208+H2308	P208	1,99	
UKP208+HE2308	1¼	115/16	7¼	513/32	21/8	43/64	25/32	45/64	315/16	223/32	1,811	½			UK208+HE2308			
UKP208+HS2308	13/8														UK208+HS2308			
UKP209+H2309	40	54	190	146	54	17	20	20	106	69	50	M14	32395	20235	UK209+H2309	P209	1,29	
UKP209+HA2309	17/16																	
UKP209+HE2309	1½	21/8	715/32	5¾	21/8	43/64	25/32	25/32	411/64	223/32	1,969	½			UK209+HE2309			
UKP209+HS2309	15/8														UK209+HS2309			
UKP210+H2310	45	57,2	206	159	60	20	23	21	113	74,5	55	M16	33345	22135	UK210+H2310	P210	2,83	
UKP210+HS2310	15/8																	
UKP210+HA2310	111/16	2¼	81/8	6¼	23/8	25/32	29/32	53/64	429/64	215/16	2,165	5/8			UK210+HA2310			
UKP210+HE2310	1¾														UK210+HE2310			
UKP211+H2311	50	63,5	219	171	60	20	23	23	125	76	59	M16	41230	27930	UK211+H2311	P211	3,46	
UKP211+HS2311	17/8																	
UKP211+HA2311	115/16	2½	85/8	647/64	23/8	25/32	29/32	29/32	459/64	3	2,323	5/8			UK211+HA2311			
UKP211+HE2311	2														UK211+HE2311			
UKP212+H2312	55	69,8	241	184	70	20	23	25	138	89	62	M16	49780	34390	UK212+H2312	P212	4,95	
UKP212+HS2312	21/8	2¾	9½	7¼	2¾	25/32	29/32	63/64	57/16	3½	2,441	5/8						
UKP213+H2313	60	76,2	265	203	70	25	28	27	150	89	65	M20	54340	38095	UK213+H2313	P213	5,06	
UKP213+HA2313	23/16																	
UKP213+HE2313	2¼	3	107/16	8	2¾	63/64	13/32	11/16	529/32	3½	2,559	¾			UK213+HE2313			
UKP213+HS2313	23/8														UK213+HS2313			
UKP215+H2315	65	82,6	275	217	74	25	28	28	162	-	73	M20	64030	45885	UK215+H2315	P215	7,27	
UKP215+HA2315	27/16	3¼	1053/64	835/64	229/32	63/64	13/32	13/32	63/8	-	2,874	¾						
UKP215+HE2315	2½														UK215+HE2315			
UKP216+H2316	70	88,9	292	232	78	25	28	30	174	-	78	M20	69065	50350	UK216+H2316	P216	8,36	
UKP216+HA2316	211/16	3½	11½	91/8	31/16	63/64	13/32	13/16	627/32	-	3,071	¾						
UKP216+HE2316	2¾														UK216+HE2316			
UKP217+H2317	75	95,2	310	247	83	25	28	32	185	-	82	M20	79800	58805	UK217+H2317	P217	10,23	
UKP217+HA2317	215/16	3¾	1213/64	923/32	317/64	63/64	13/32	1¼	79/32	-	3,228	¾						
UKP217+HE2317	3														UK217+HE2317			
UKP218+H2318	80	101,6	327	262	88	27	30	33	198	-	86	M22	91295	67925	UK218+H2318	P218	12,34	
UKP218+HA2318	33/16	4	127/8	105/16	315/32	11/16	13/16	119/64	751/64	-	3,386	7/8						

Manguitos HA; HE; HS con rosca en pulgadas
Inch dimension adapter sleeves HA; HE; HS

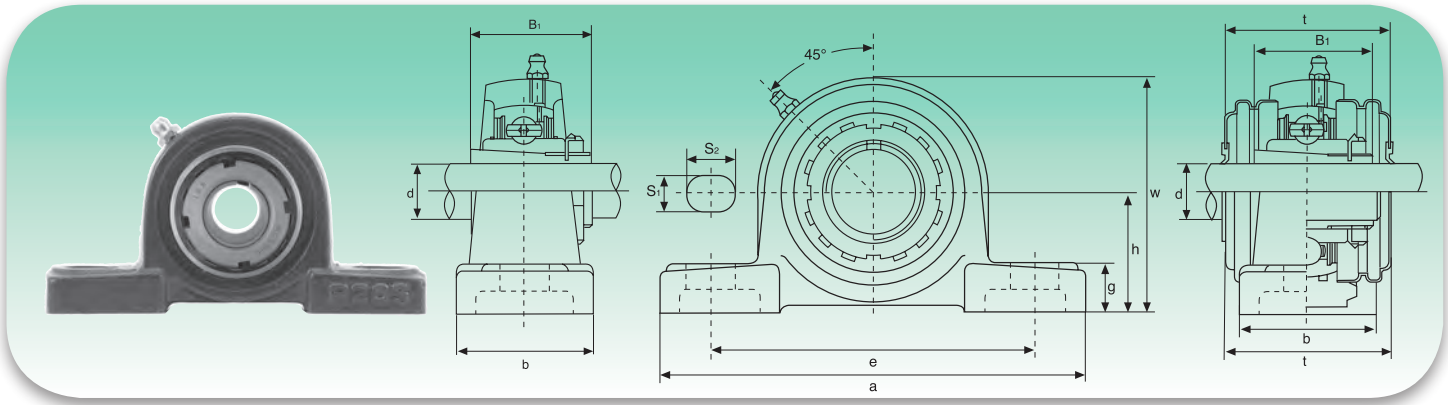
UKP3 Serie pesada - Heavy duty

Tipo Type	Dimensiones - Dimensions										Bul. fj. Bolt Size	Coeficientes de carga (N) Load ratings (N)		Rodamiento Bearing	Soporte Housing	Peso Weight	
	d	h	a	e	b	S ₁	S ₂	g	w	B ₁		Dinámica C Dynamic C	Estática C ₀ Static C ₀				kg
	mm/inch											mm/inch					
UKP305+H2305 UCP305+HE2305	20 ¾	45 149/64	175 67/8	132 53/16	45 1¾	17 43/64	20 19/32	15 25/32	85 311/32	35 1,378	M14 ½	20140	10355	UK305+H2305 UK305+HE2305	P305	1,7	
UKP306+H2306 UKP306+HS2306 UKP306+HE2306	25 7/8 1	50 131/32	180 73/32	140 5½	50 131/32	17 43/64	20 25/32	18 23/32	95 3¾	38 1,496	M14 ½	25365	14250	UK306+H2306 UK306+HS2306 UK306+HE2306	P306	2,3	
UKP307+H2307 UKP307+HS2307	30 11/8	56 213/64	210 89/32	160 65/16	56 27/32	17 43/64	25 63/64	20 25/32	106 43/16	43 1,693	M14 ½	31730	18335	UK307+H2307 UK307+HS2307	P307	3,0	
UKP308+H2308 UKP308+HE2308 UKP308+HS2308	35 1¼ 13/8	60 223/64	220 821/32	170 611/16	60 23/8	17 43/64	27 11/16	22 7/8	116 49/16	46 1,811	M16 5/8	38665	22800	UK308+H2308 UK308+HE2308 UK308+HS2308	P308	3,8	
UKP309+H2309 UKP309+HA2309 UKP309+HE2309 UKP309+HS2309	40 17/16 1½ 15/8	67 141/64	245 921/32	190 715/32	67 25/8	20 25/32	30 13/16	24 15/16	129 53/32	50 1,969	M16 5/8	46455	28025	UK309+H2309 UK309+HA2309 UK309+HE2309 UK309+HS2309	P309	5,0	
UKP310+H2310 UKP310+HS2310 UKP310+HA2310 UKP310+HE2310	45 15/8 111/16 1¾	75 261/64	275 1013/16	212 811/32	75 215/16	20 25/32	35 13/8	27 11/16	143 55/8	55 2,165	M16 5/8	58900	36385	UK310+H2310 UK310+HS2310 UK310+HA2310 UK310+HE2310	P310	6,7	
UKP311+H2311 UKP311+HS2311 UKP311+HA2311 UKP311+HE2311	50 17/8 115/16 2	80 35/32	310 127/32	236 99/32	80 35/32	20 25/32	38 1½	30 13/16	154 61/16	59 2,323	M16 5/8	68020	42750	UK311+H2311 UK311+HS2311 UK311+HA2311 UK311+HE2311	P311	8,1	
UKP312+H2312 UKP312+HS2312	55 21/8	85 311/32	330 12	250 927/32	85 311/32	25 63/64	38 1½	32 1¼	165 6½	62 2,441	M20 ¾	77805	49590	UK312+H2312 UK312+HS2312	P312	9,4	
UKP313+H2313 UKP313+HA2313 UKP313+HE2313 UKP313+HS2313	60 23/16 2¼ 23/8	90 335/64	340 133/8	260 10¼	90 317/32	25 63/64	38 1½	33 15/16	176 615/16	65 2,559	M20 ¾	88065	56905	UK313+H2313 UK313+HA2313 UK313+HE2313 UK313+HS2313	P313	10,8	
UKP315+H2315 UKP315+HA2315 UKP315+HE2315	65 27/16 2½	100 315/16	380 1431/32	290 1113/32	100 315/16	27 11/16	40 19/18	35 13/8	198 725/32	73 2,874	M22 7/8	107350	73340	UK315+H2315 UK315+HA2315 UK315+HE2315	P315	14,9	
UKP316+H2316 UKP316+HA2316 UKP316+HE2316	70 211/16 2¾	106 411/64	400 15¾	300 1113/16	110 411/32	27 11/16	40 19/16	40 19/16	210 89/32	78 3,071	M22 7/8	116850	82365	UK316+H2316 UK316+HA2316 UK316+HE2316	P316	18,6	
UKP317+H2317 UKP317+HA2317 UKP317+HS2317	75 215/16 3	112 411/64	420 1617/32	320 1219/32	110 411/32	33 15/16	45 125/32	40 19/16	220 821/32	82 3,228	M27 1	126350	91960	UK317+H2317 UK317+HA2317 UK317+HS2317	P317	20,2	
UKP318+H2318 UKP318+HA2318	80 33/16	118 441/64	430 1615/16	330 13	110 411/32	33 15/16	45 125/32	45 125/32	235 9¼	86 3,386	M27 1	135850	101650	UK318+H2318 UK318+HA2318	P318	22,8	
UKP319+H2319 UKP319+HA2319	85 35/16	125 459/64	470 18½	360 143/16	120 423/32	36 113/32	50 131/32	45 125/32	250 927/32	90 3,543	M30 11/8	145350	113050	UK319+H2319 UK319+HA2319	P319	29,3	
UKP320+H2320 UKP320+HA2320	90 37/16	140 533/64	490 199/32	380 1431/32	120 423/32	36 113/32	50 131/32	50 1053/64	275 3,814	97 3,814	M30 11/8	164350	133950	UK320+H2320 UK320+HA2320	P320	34,8	
UKP322+H2322 UKP322+HA2322	100 315/16	150 529/32	520 2015/32	400 15¾	140 5½	40 19/16	55 25/32	55 25/32	300 1113/16	105 4,134	M33 1¼	194750	171000	UK322+H2322 UK322+HA2322	P322	43,9	
UKP324+H2324 UKP324+HA2324	110 43/16	160 619/64	570 227/16	450 1723/32	140 5½	40 19/16	55 25/32	65 121/32	320 1219/32	112 4,410	M33 1¼	196650	175750	UK324+H2324 UK324+HA2324	P324	55,7	
UKP326+H2326 UKP326+HA2326	115 47/16	180 73/32	600 235/8	480 1829/32	140 5½	40 19/16	55 25/32	75 261/64	335 1331/32	121 4,764	M33 1¼	217550	203300	UK326+H2326 UK326+HA2326	P326	71,9	
UKP328+H2328 UKP328+HA2328	125 415/16	200 77/8	620 2413/32	500 1911/16	140 5½	40 19/16	55 25/32	75 261/64	390 1532/64	131 5,158	M33 1¼	240350	233700	UK328+H2328 UK328+HA2328	P328	92,5	

Manguitos HA; HE; HS con rosca en pulgadas
Inch dimension adapter sleeves HA; HE; HS

UKPX Serie media - Medium duty

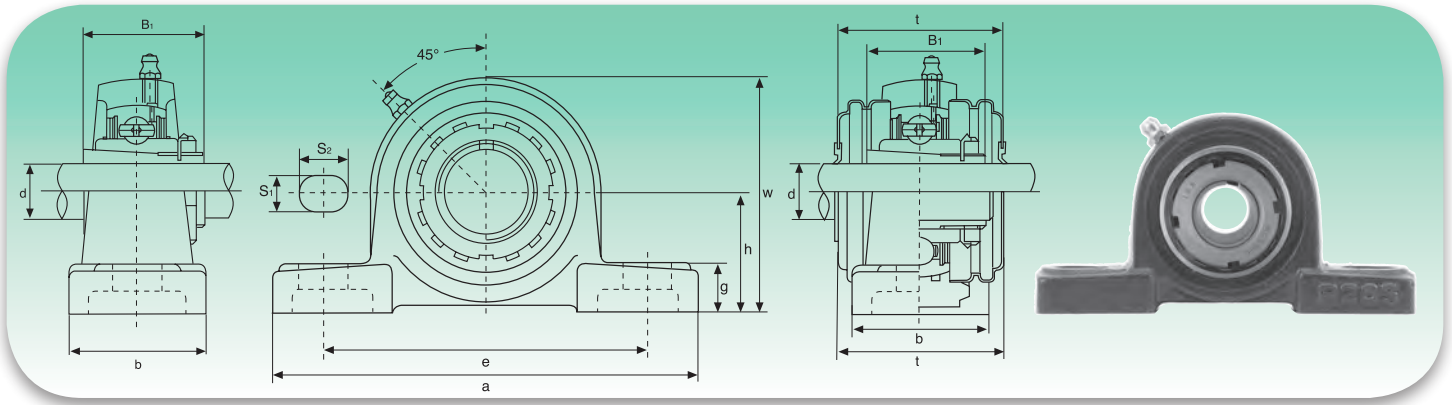

Tipo Type	Dimensiones - Dimensions										Bul. fj. Bolt Size	Coeficientes de carga (N) Load ratings (N)		Rodamiento Bearing	Soporte Housing	Peso Weight	
	d	h	a	e	b	S ₁	S ₂	g	w	B ₁		Dinámica C Dynamic C	Estática C ₀ Static C ₀				kg
	mm/inch											mm/inch					
UKPX05+H2305	20	44,4	159	119	51	17	20	18	85	35	M14	18525	10735	UKX05+H2305	PX05	1,5	
UKPX05+HE2305	¾	1¾	6¼	411/16	2	43/64	25/32	311/32	1,378	½	½						
UKPX06+H2306	25	47,6	175	127	57	17	20	20	93	38	M14	24415	14630	UKX06+H2306	PX06	2,1	
UKPX06+HS2306	7/8	17/8	67/8	5	2¼	43/64	25/32	25/32	321/32	1,496	½						
UKPX06+HE2306	1																
UKPX07+H2307	30	54,0	203	144	57	17	20	21	105	43	M14	27645	16910	UKX07+H2307	PX07	2,7	
UKPX07+HS2307	11/8	21/8	8	521/32	2¼	43/64	25/32	13/16	41/8	1,693	½						
UKPX08+H2308	35	58,7	222	156	67	20	23	26	111	46	M16	32395	20235	UKX08+H2308	PX08	3,5	
UKPX08+HE2308	1¼	25/16	8¾	65/32	25/8	25/32	29/32	11/32	43/8	1,811	5/8						
UKPX08+HS2308	13/8																
UKPX09+H2309	40	58,7	222	156	67	20	23	26	116	50	M16	33345	22135	UKX09+H2309	PX09	3,7	
UKPX09+HA2309	17/16	25/16	8¾	65/32	25/8	25/32	29/32	11/32	49/18	1,969	5/8						
UKPX09+HE2309	1½																
UKPX09+HS2309	15/8																
UKPX10+H2310	45	63,5	241	171	73	20	23	27	126	55	M16	41230	27930	UKX10+H2310	PX10	4,6	
UKPX10+HS2310	15/8	2½	9½	647/64	27/8	25/32	29/32	11/16	431/32	2,165	5/8						
UKPX10+HA2310	111/16																
UKPX10+HE2310	1¾																
UKPX11+H2311	50	69,8	260	184	79	25	28	30	137	59	M20	49780	34390	UKX11+H2311	PX11	6,2	
UKPX11+HS2311	17/8	2¾	10¼	7¼	31/8	31/32	13/32	13/16	513/32	2,323	¾						
UKPX11+HA2311	115/16																
UKPX11+HE2311	2																
UKPX12+H2312	55	76,2	286	203	83	25	28	33	151	62	M20	54340	38095	UKX12+H2312	PX12	7,5	
UKPX12+HS2312	21/8	3	11¼	8	39/32	63/64	13/32	15/16	2,441	¾	¾						
UKPX13+H2313	60	76,2	286	203	83	25	28	33	154	65	M20	59090	41895	UKX13+H2313	PX13	7,8	
UKPX13+HA2313	23/16	3	11¼	8	39/32	63/64	13/32	15/16	61/16	2,559	¾						
UKPX13+HE2313	2¼																
UKPX13+HS2313	23/8																
UKPX15+H2315	65	88,9	330	229	89	27	30	35	175	73	M22	69065	50350	UKX15+H2315	PX15	10,5	
UKPX15+HA2315	27/16	3½	13	91/32	3½	11/16	13/16	13/8	67/8	2,874	7/8						
UKPX15+HS2315	2½																
UKPX16+H2316	70	101,6	381	283	102	27	30	40	194	78	M22	79800	58805	UKX16+H2316	PX16	15,4	
UKPX16+HA2316	211/16	4	15	115/32	41/32	11/16	13/16	19/16	75/8	3,071	7/8						
UKPX16+HS2316	2¾																
UKPX17+H2317	75	101,6	381	283	102	27	30	40	200	82	M22	91295	67925	UKX17+H2317	PX17	15,8	
UKPX17+HA2317	215/16	4	15	115/32	41/32	11/16	13/16	19/16	77/8	3,228	7/8						
UKPX17+HE2317	3																
UKPX18+H2318	80	101,6	381	283	111	27	30	40	206	86	M22	103550	77805	UKX18+H2318	PX18	18,6	
UKPX18+HA2318	33/16	4	15	115/32	43/8	11/16	13/16	19/16	81/8	3,386	7/8						
UKPX20+H2320	3½											5	17	139/32	4¾	15/16	113/32
UKPX20+HA2320												126350	99750	UKX20+H2320	PX20	29,3	

Manguitos HA; HE; HS con rosca en pulgadas
Inch dimension adapter sleeves HA; HE; HS

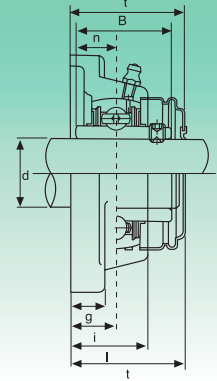
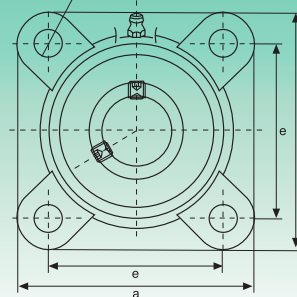
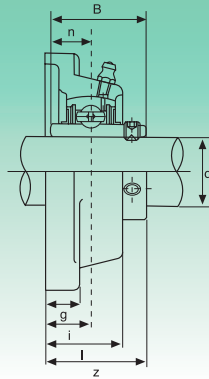

Tipo Type	Dimensiones - Dimensions											Bul. fij. Bolt Size	Coeficientes de carga (N) Load ratings (N)		Rodamiento Bearing	Soporte Housing	Peso Weight	
	d	a	e	i	g	l	s	z	t	B	n		Dinámica C Dynamic C	Estática C ₀ Static C ₀				kg
	mm/inch												mm/inch					
UCF201	12	86	64	15	12	25,5	12	33,3	37,5	31	12,7	M10	12160	6318	UC201	F204	0,60	
UCF201-8	3/4	33/8	233/64	19/32	15/32	1	15/32	15/16	131/64	1,2205	0,500	3/8			UC201-8		0,59	
UCF202	15	86	64	15	12	25,5	12	33,3	37,5	31	12,7	M10	12160	6318	UC202	F204	0,59	
UCF202-9	9/16	33/8	233/64	19/32	15/32	1	15/32	15/16	131/64	1,2205	0,500	3/8			UC202-9		0,59	
UCF202-10	5/8														UC202-10		0,59	
UCF203	17	86	64	15	12	25,5	12	33,3	37,5	31	12,7	M10	12160	6318	UC203	F204	0,58	
UCF203-11	11/16	33/8	233/64	19/32	15/32	1	15/32	15/16	131/64	1,2205	0,500	3/8			UC203-11		0,57	
UCF204	20	86	64	15	12	25,5	12	33,3	37,5	31	12,7	M10	12160	6318	UC204	F204	0,56	
UCF204-12	3/4	33/8	233/64	19/32	15/32	1	15/32	15/16	131/64	1,2205	0,500	3/8			UC204-12		0,56	
UCF205	25	95	70	16	14	27	12	35,8	40	34,1	14,3	M10			UC205	F205	0,80	
UCF205-13	13/16														UC205-13		0,84	
UCF205-14	7/8	3/4	2/4	5/8	35/64	11/16	15/32	113/32	19/16	1,3425	0,563	3/8	13300	7457	UC205-14		0,83	
UCF205-15	15/16														UC205-15		0,81	
UCF205-16	1														UC205-16		0,80	
UCF206	30	108	83	18	14	31	12	40,2	44,5	38,1	15,9	M10			UC206	F206	1,12	
UCF206-17	11/16														UC206-17		1,15	
UCF206-18	11/8	4/4	317/64	45/64	35/64	17/32	15/32	119/32	1/4	1,5000	0,626	3/8	18525	10735	UC206-18		1,14	
UCF206-19	13/15														UC206-19		1,12	
UCF206-20	1/4														UC206-20		1,11	
UCF207	35	117	92	19	16	34	14	44,4	48,5	42,9	17,5	M12			UC207	F207	1,46	
UCF207-20	1/4														UC207-20		1,52	
UCF207-21	15/16	439/64	35/8	3/4	5/8	111/32	35/64	1/4	129/32	1,6890	0,689	7/16	24415	14630	UC207-21		1,49	
UCF207-22	13/8														UC207-22		1,46	
UCF207-23	17/16														UC207-23		1,43	
UCF208	40	130	102	21	16	36	16	51,2	55,5	49,2	19	M14			UC208	F208	1,84	
UCF208-24	1/2	51/8	41/64	53/64	5/8	127/64	5/8	21/64	23/16	1,9370	0,748	1/2	27645	16910	UC208-24		1,88	
UCF208-25	19/16														UC208-25		1,85	
UCF209	45	137	105	22	18	38	16	52,2	56,5	49,2	19	M14			UC209	F209	2,15	
UCF209-26	15/8														UC209-26		2,25	
UCF209-27	111/16	513/32	49/64	55/64	23/32	1/2	5/8	21/16	27/32	1,9370	0,748	1/2	32395	20235	UC209-27		2,21	
UCF209-28	1/4														UC209-28		2,17	
UCF210	50	143	111	22	18	40	16	54,6	59,5	51,6	19	M14			UC210	F210	2,42	
UCF210-29	113/16														UC210-29		2,54	
UCF210-30	17/8	55/8	43/8	55/64	23/32	19/16	5/8	25/32	211/32	2,0315	0,748	1/2	33345	22135	UC210-30		2,49	
UCF210-31	115/16														UC210-31		2,44	
UCF210-32	2														UC210-32		2,40	
UCF211	55	162	130	25	20	43	19	58,4	63	55,6	22,2	M16			UC211	F211	3,31	
UCF211-32	2														UC211-32		3,46	
UCF211-33	21/16	63/8	51/8	63/64	25/32	111/16	3/4	15/16	231/64	2,1890	0,874	5/8	41230	27930	UC211-33		3,40	
UCF211-34	21/8														UC211-34		3,35	
UCF211-35	23/16														UC211-35		3,29	
UCF212	60	175	143	29	20	48	19	68,7	73,5	65,1	25,4	M16			UC212	F212	4,28	
UCF212-36	2/4														UC212-36		4,41	
UCF212-37	25/16	657/64	55/8	19/64	25/32	157/64	3/4	245/64	257/64	2,5630	1,000	5/8	49780	34390	UC212-37		4,33	
UCF212-38	23/8														UC212-38		4,26	
UCF212-39	27/16														UC212-39		4,19	
UCF213	65	187	149	30	22	50	19	69,7	74,5	65,1	25,4	M16			UC213	F213	4,99	
UCF213-40	2/2	723/64	555/64	13/16	55/64	131/32	3/4	2/4	215/16	2,5630	1,000	5/8	54340	38095	UC213-40		5,08	
UCF213-41	29/16														UC213-41		4,99	
UCF214	70	193	152	31	22	54	19	75,4	81,5	74,6	30,2	M16			UC214	F214	5,85	
UCF214-42	25/8														UC214-42		6,06	
UCF214-43	211/16	719/32	563/64	17/32	55/64	21/8	3/4	221/32	313/64	2,9370	1,189	5/8	59090	41895	UC214-43		5,96	
UCF214-44	2/4														UC214-44		5,86	
UCF215	75	200	159	34	22	56	19	78,5	83,5	77,8	33,3	M16			UC215	F215	6,91	
UCF215-45	213/16														UC215-45		7,16	
UCF215-46	27/8	77/8	617/64	111/32	55/64	27/32	3/4	33/32	39/32	3,0630	1,311	5/8	64030	45885	UC215-46		7,05	
UCF215-47	215/16														UC215-47		6,94	
UCF215-48	3														UC215-48		6,82	
UCF216	80	208	165	34	22	58	23	83,3	88,5	82,6	33,3	M20			UC216	F216	7,50	
UCF216-49	31/16														UC216-49		7,68	
UCF216-50	31/8	83/16	6/2	111/32	55/64	29/32	29/32	39/32	339/64	3,2520	1,311	3/4	69065	50350	UC216-50		7,55	
UCF216-51	33/16														UC216-51		7,42	
UCF217	85	220	175	36	24	63	23	87,6	92,6	85,7	34,1	M20			UC217	F217	9,66	
UCF217-52	3/4														UC217-52		9,88	
UCF217-53	35/6	821/33	657/64	127/64	15/16	215/32	29/32	37/16	341/64	3,3740	1,343	3/4	79800	58805	UC217-53		9,74	
UCF217-55	37/16														UC217-55		9,45	
UCF218	90	235	187	40	24	68	23	96,3	101,5	96	39,7	M20			UC218	F218	12,06	
UCF218-56	3/2	9/4	723/64	137/64	15/16	211/16	29/32	325/32	4	3,7795	1,5630	3/4	91295	67925	UC218-56		12,17	

Disponibile en acero inox. Soporte: AISI 304 - Rodamiento: AISI 440C - Available stainless steel Housing: AISI 304 - Bearing: AISI 440C
 Disponible bajo demanda con rodamiento SA (SAF.) - Available under request with SA bearing (SAF.)

HCF2 Serie normal - Standard duty

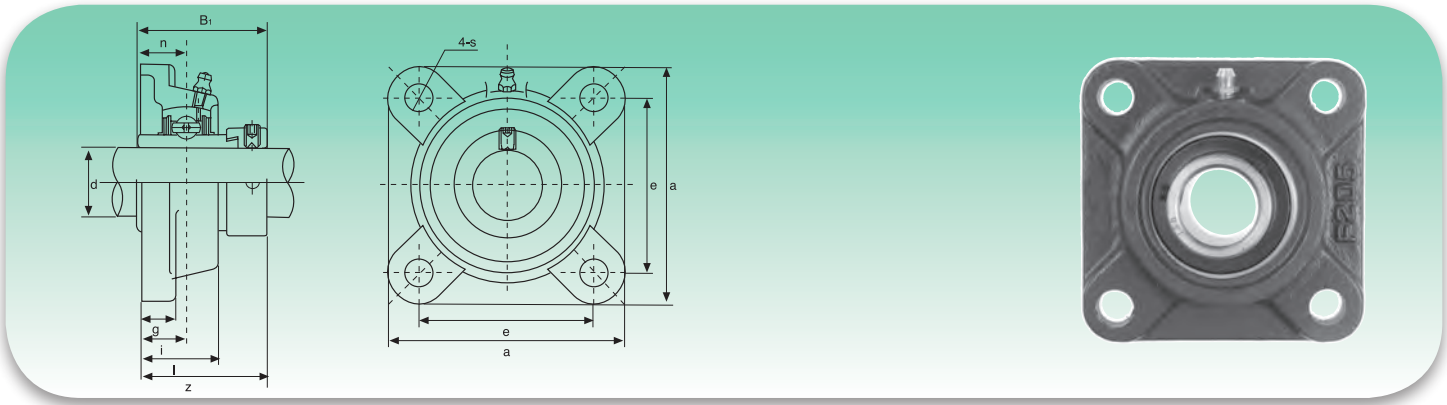

Tipo Type	Dimensiones - Dimensions										Bul. fij. Bolt Size	Coeficientes de carga (N) Load ratings (N)		Rodamiento Bearing	Soporte Housing	Peso Weight	
	d	a	e	i	g	l	s	z	B ₁	n		Dinámica C Dynamic C	Estática C ₀ Static C ₀				kg
	mm/inch											mm/inch					
HCF204	20	86	64	15	12	25,5	12	41,6	43,7	17,1	M10	12160	6318	HC204	F204	0,63	
HCF204-12	¾	33/8	233/64	19/32	15/32	1	15/32	141/64	1,720	0,673	3/8			HC204-12		0,63	
HCF205	25	95	70	16	14	27	12	42,9	44,4	17,5	M10			HC205		0,87	
HCF205-13	13/16													HC205-13		0,92	
HCF205-14	7/8	3¾	2¾	5/8	35/64	11/16	15/32	111/16	1,748	0,689	3/8	13300	7457	HC205-14	F205	0,91	
HCF205-15	15/16													HC205-15		0,89	
HCF205-16	1													HC205-16		0,87	
HCF206	30	108	83	18	14	31	12	48,1	48,4	18,3	M10			HC206		1,25	
HCF206-17	11/16													HC206-17		1,30	
HCF206-18	11/8	4¼	317/64	45/64	35/64	17/32	15/32	157/64	1,906	0,720	3/8	18525	10735	HC206-18	F206	1,27	
HCF206-19	13/16													HC206-19		1,25	
HCF206-20	1¼													HC206-20		1,24	
HCF207	35	117	92	19	16	34	14	51,3	51,1	18,8	M12			HC207		1,58	
HCF207-20	1¼													HC207-20		1,65	
HCF207-21	15/16	439/64	35/8	¾	5/8	111/32	35/64	21/64	2,012	0,740	7/16	24415	14630	HC207-21	F207	1,61	
HCF207-22	13/8													HC207-22		1,58	
HCF207-23	17/16													HC207-23		1,55	
HCF208	40	130	102	21	16	36	16	55,9	56,3	21,4	M14			HC208		1,99	
HCF208-24	1½	51/8	41/64	53/64	5/8	127/32	5/8	213/64	2,217	0,843	½	27645	16910	HC208-24	F208	2,04	
HCF208-25	19/16													HC208-25		2,00	
HCF209	45	137	105	22	18	38	16	56,9	56,3	21,4	M14			HCF209		2,32	
HCF209-26	15/8													HC209-26		2,43	
HCF209-27	111/16	513/32	49/64	55/64	55/64	1½	5/8	215/64	2,217	0,843	½	32395	20235	HC209-27	F209	2,38	
HCF209-28	1¾													HC209-28		2,34	
HCF210	50	143	111	22	18	40	16	60,1	62,7	24,6	M14			HCF210		2,61	
HCF210-29	113/16													HC210-29		2,76	
HCF210-30	17/8	55/8	43/8	55/64	55/64	19/16	5/8	23/8	2,469	0,969	½	33345	22135	HC210-30	F210	2,70	
HCF210-31	115/16													HC210-31		2,64	
HCF210-32	2													HC210-32		2,58	
HCF211	55	162	130	25	20	43	19	68,6	71,4	27,8	M16			HCF211		3,52	
HCF211-32	2													HC211-32		3,72	
HCF211-33	22/16	63/8	51/8	63/64	25/32	111/16	¾	245/64	2,811	1,094	5/8	41230	27930	HC211-33	F211	3,64	
HCF211-34	21/8													HC211-34		3,57	
HCF211-35	23/16													HC211-35		3,49	
HCF212	60	175	143	29	20	48	19	75,8	77,8	31	M16			HC212		4,62	
HCF212-36	2¼													HC212-36		4,78	
HCF212-37	25/16	657/64	55/8	19/64	25/32	157/64	¾	263/64	3,063	1,220	5/8	49780	34390	HC212-37	F212	4,69	
HCF212-38	23/8													HC212-38		4,64	
HCF212-39	27/16													HC212-39		4,51	
HCF213	65	187	149	30	22	50	19	81,6	85,7	34,1	M16			HC213		5,55	
HCF213-40	2½	723/64	555/64	13/16	55/64	131/32	¾	37/32	3,374	1,343	5/8	54340	38095	HC213-40	F213	5,65	
HCF213-41	29/16													HC213-41		5,54	
HCF214	70	193	152	31	22	54	19	82,6	85,7	34,1	M16			HC214		6,35	
HCF214-42	23/8													HC214-42		6,59	
HCF214-43	211/16	719/32	563/64	17/32	55/64	21/8	¾	3¼	3,374	1,343	5/8	59090	41895	HC214-43	F214	6,48	
HCF214-44	2¾													HC214-44		6,36	
HCF215	75	200	159	34	22	56	19	88,8	92,1	37,3	M16			HC215		7,54	
HCF215-45	213/16													HC215-45		7,84	
HCF215-46	27/8	77/8	617/64	111/32	55/64	27/32	¾	3½	3,626	1,426	5/8	64030	45885	HC215-46	F215	7,71	
HCF215-47	215/16													HC215-47		7,58	
HCF215-48	3													HC215-48		7,44	

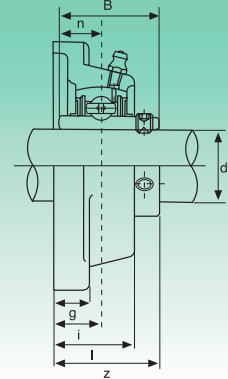
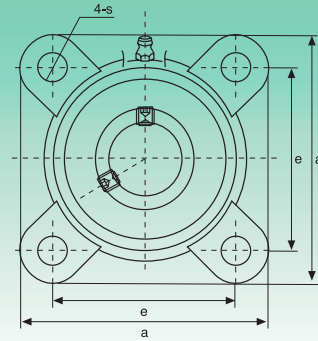

Tipo Type	Dimensiones - Dimensions										Bul. fj. Bolt Size	Coeficientes de carga (N) Load ratings (N)		Rodamiento Bearing	Soporte Housing	Peso Weight kg								
	d	a	e	i	g	l	s	z	B	n		Dinámica C Dynamic C	Estática C ₀ Static C ₀											
	mm/inch											mm/inch												
UCF305 UCF305-13 UCF305-14 UCF305-15 UCF305-16	25 13/16 7/8 15/16 1	110	80	16	13	29	16	39	38	15	M14	20140	10355	UC305 UC305-13 UC305-14 UC305-15 UC305-16	F305	1,1								
UCF306 UCF306-17 UCF306-18 UCF306-19	30 11/16 11/8 13/16	125	95	18	15	32	16	44	43	17	M14			25365			14250	UC306 UC306-17 UC306-18 UC306-19	F306	1,6				
UCF307 UCF307-20 UCF307-21 UCF307-22 UCF307-23	35 1 1/4 15/16 13/8 17/16	135	100	20	16	36	19	49	48	19	M16							31730			18335	UC307 UC307-20 UC307-21 UC307-22 UC307-23	F307	2
UCF308 UCF308-24 UCF308-25	40 1 1/2 19/6	150	112	23	17	40	19	56	52	19	M16											38665		
UCF309 UCF309-26 UCF309-27 UCF309-28	45 15/8 111/16 1 3/4	160	125	25	18	44	19	60	57	22	M16			46455			28025		UC309 UC309-26 UC309-27 UC309-28	F309				
UCF310 UCF310-29 UCF310-30 UCF310-31	50 113/16 17/8 115/16	175	132	28	19	48	23	67	61	22	M20	58900	36385		UC310 UC310-29 UC310-30 UC310-31	F310			4,5					
UCF311 UCF311-32 UCF311-33 UCF311-34 UCF311-35	55 2 21/16 21/8 23/16	185	140	30	20	52	23	71	66	25	M20				68020			42750			UC311 UC311-32 UC311-33 UC311-34 UC311-35	F311	5,5	
UCF312 UCF312-36 UCF312-37 UCF312-38 UCF312-39	60 2 1/4 25/16 23/8 27/16	195	150	33	22	56	23	78	71	26	M20			77805			49590			UC312 UC312-36 UC312-37 UC312-38 UC312-39	F312			6,5
UCF313 UCF313-40 UCF313-41	65 2 1/2 29/16	208	166	33	22	58	23	78	75	30	M20									88065				
UCF314 UCF314-42 UCF314-43 UCF314-44	70 25/8 211/16 2 3/4	226	178	36	25	61	25	81	78	33	M22	98800	64790		UC314 UC314-42 UC314-43 UC314-44	F314		9,5						
UCF315 UCF315-45 UCF315-46 UCF315-47 UCF315-48	75 213/16 27/8 215/16 3	236	184	39	25	66	25	89	82	32	M22				107350				73340	UC315 UC315-45 UC315-46 UC315-47 UC315-48		F315	12	
UCF316 UCF316-49 UCF316-50 UCF316-51	80 31/16 31/8 33/16	250	196	38	27	68	31	90	86	34	M27			116850			82365			UC316 UC316-49 UC316-50 UC316-51	F316			14
UCF317 UCF317-52 UCF317-53 UCF317-55	85 3 3/4 35/16 37/16	260	204	44	27	74	31	100	96	40	M27	126350	91960			UC317 UC317-52 UC317-53 UC317-55		F317		16				
UCF318 UCF318-55 UCF318-56	90 37/16 3 1/2	280	216	44	30	76	35	100	96	40	M30					135850								
UCF319 UCF319-58 UCF319-59 UCF319-60	95 35/8 311/16 3 3/4	290	228	59	30	94	35	121	103	41	M30			145350	113050		UC319 UC319-58 UC319-59 UC319-60		F319		22			
UCF320 UCF320-61 UCF320-62 UCF320-63 UCF320-64	100 313/16 37/8 315/16 4	310	242	59	32	94	38	125	108	42	M33					164350	133950					UC320 UC320-61 UC320-62 UC320-63 UC320-64	F320	25
UCF321	105	310	242	59	32	94	38	127	-	44	M33	174800	145350					UC321		F321		25,6		
UCF322	110	340	266	60	35	96	41	131	-	46	M36			194750	171000			UC322	F322		34,7			
UCF324	120	370	290	65	40	110	41	140	-	51	M36	196650	175750					UC324		F324		47,2		
UCF326	130	410	320	65	45	115	41	146	-	54	M36			217550	203300	UC326	F326	62,7						
UCF328	140	450	350	75	55	125	41	161	-	59	M36	240350	233700			UC328			F328	87,0				

UCFS3 Serie pesada - Heavy duty

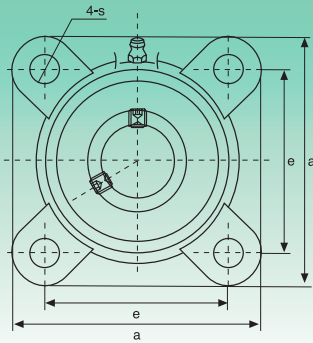
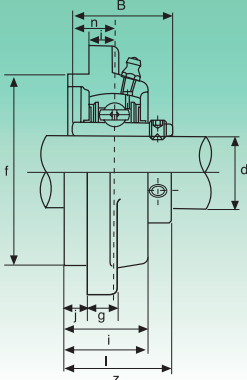

Tipo Type	Dimensiones - Dimensions											Bul. fj. Bolt Size	Coeficientes de carga (N) Load ratings (N)		Rodamiento Bearing	Soporte Housing	Peso Weight		
	d	a	e	i	s	j	g	l	f	z	B		n	Dinámica C Dynamic C				Estática C ₀ Static C ₀	kg
	mm/inch												mm/inch						
UCFS305 UCFS305-13 UCFS305-14 UCFS305-15 UCFS305-16	25 13/16 7/8 15/16 1	110	80	9	16	7	13	29	80	39	38	15	M14 1/2	20140	10355	UC305 UC305-13 UC305-14 UC305-15 UC305-16	FS305	1,3	
UCFS306 UCFS306-17 UCFS306-18 UCFS306-19	30 11/16 11/8 13/16	125	95	10	16	8	15	32	90	44	43	17	M14 1/2	25365	14250	UC306 UC306-17 UC306-18 UC306-19	FS306	1,9	
UCFS307 UCFS307-20 UCFS307-21 UCFS307-22 UCFS307-23	35 1 1/4 15/16 13/8 17/16	135	100	11	19	9	16	36	100	49	48	19	M16 5/8	31730	18335	UC307 UC307-20 UC307-21 UC307-22 UC307-23	FS307	2,4	
UCFS308 UCFS308-25 UCFS308-25	40 1 1/2 19/16	150	112	13	19	10	17	40	115	56	52	19	M16 5/8	38665	22800	UC308 UC308-24 UC308-25	FS308	3,3	
UCFS309 UCFS309-26 UCFS309-27 UCFS309-28	45 15/8 111/16 1 3/4	160	125	14	19	11	18	44	125	60	57	22	M16 5/8	46455	28020	UC309 UC309-26 UC309-27 UC309-28	FS309	4,0	
UCFS310 UCFS310-29 UCFS310-30 UCFS310-31	50 113/16 17/8 115/16	175	132	16	23	12	19	48	140	67	61	22	M20 3/4	58900	36385	UC310 UC310-29 UC310-30 UC310-31	FS310	5,3	
UCFS311 UCFS311-32 UCFS311-33 UCFS311-34 UCFS311-35	55 2 21/16 21/8 23/16	185	140	17	23	13	20	52	150	71	66	26	M20 3/4	68020	42750	UC311 UC311-32 UC311-33 UC311-34 UC311-35	FS311	6,2	
UCFS312 UCFS312-36 UCFS312-37 UCFS312-38 UCFS312-39	60 2 1/4 25/16 23/8 27/16	195	150	19	23	14	22	56	160	78	71	25	M20 3/4	77805	49590	UC312 UC312-36 UC312-37 UC312-38 UC312-39	FS312	7,2	
UCFS313 UCFS313-40 UCFS313-41	65 2 1/2 29/16	208	166	15	23	18	22	58	175	78	75	30	M20 3/4	88065	56905	UC313 UC313-40 UC313-41	FS313	8,9	
UCFS314 UCFS314-42 UCFS314-43 UCFS314-44	70 25/8 211/16 2 3/4	223	178	18	25	18	25	61	185	81	78	33	M20 3/4	98800	64790	UC314 UC314-42 UC314-43 UC314-44	FS314	11	
UCFS315 UCFS315-45 UCFS315-46 UCFS315-47 UCFS315-48	75 213/16 27/8 215/16 3	236	184	21	25	18	25	66	200	89	82	32	M22 7/8	107350	73340	UC315 UC315-45 UC315-46 UC315-47 UC315-48	FS315	13	
UCFS316 UCFS316-49 UCFS316-50 UCFS316-51	80 31/16 31/8 33/16	250	196	18	31	20	27	68	210	90	86	34	M27 1	116850	82365	UC316 UC316-49 UC316-50 UC316-51	FS316	15	
UCFS317 UCFS317-52 UCFS317-53 UCFS317-55	85 3 1/4 35/16 37/16	260	204	24	31	20	27	74	220	100	96	40	M27 1	126350	91960	UC317 UC317-52 UC317-53 UC317-55	FS317	17	
UCFS318 UCFS318-55 UCFS318-56	90 37/16 3 1/2	280	216	24	35	20	30	76	240	100	96	40	M30 1 1/8	135850	101650	UC318 UC318-55 UC318-56	FS318	21	
UCFS319 UCFS319-58 UCFS319-59 UCFS319-60	95 35/8 311/16 3 3/4	280	228	39	35	20	30	94	250	121	103	41	M30 1 1/8	145350	113050	UC319 UC319-58 UC319-59 UC319-60	FS319	25	
UCFS320 UCFS320-61 UCFS320-62 UCFS320-63 UCFS320-64	100 313/16 37/8 315/16 4	310	242	39	38	20	32	94	260	125	108	42	M33 1 1/4	164350	133950	UC320 UC320-61 UC320-62 UC320-63 UC320-64	FS320	30	

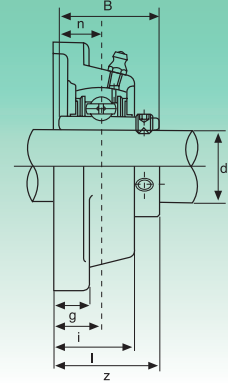
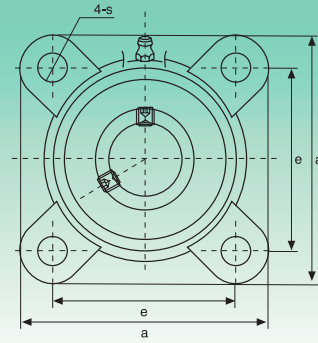

Tipo Type	Dimensiones - Dimensions										Bul. fj. Bolt Size	Coeficientes de carga (N) Load ratings (N)		Rodamiento Bearing	Soporte Housing	Peso Weight kg												
	d	a	e	i	g	l	s	z	B	n		Dinámica C Dynamic C	Estática C ₀ Static C ₀															
	mm/inch											mm/inch																
UCFX05 UCFX05-13 UCFX05-14 UCFX05-15 UCFX05-16	25 13/16 7/8 15/16 1	108	83	18	13	30	12	40,2	38,1	15,9	M10	18525	10735	UCX05 UCX05-13 UCX05-14 UCX05-15 UCX05-16	FX05	1,0												
UCFX06 UCFX06-17 UCFX06-18 UCFX06-19 UCFX06-20	30 11/16 11/8 13/16 1 1/4	117	92	19	14	34	16	44,4	42,9	17,5	M14			24415			14630	UCX06 UCX06-17 UCX06-18 UCX06-19 UCX06-20	FX06	1,7								
UCFX07 UCFX07-21 UCFX07-22 UCFX07-23	35 15/16 13/8 17/16	130	102	21	14	38	16	51,2	49,2	19	M14							27645			16910	UCX07 UCX07-21 UCX07-22 UCX07-23	FX07	2,1				
UCFX08 UCFX08-24 UCFX08-25	40 1 1/2 19/16	137	105	22	14	40	19	52,2	49,2	19	M16											32395			20235	UCX08 UCX08-24 UCX08-25	FX08	2,4
UCFX09 UCFX09-26 UCFX09-27 UCFX09-28 UCFX09-29	45 15/8 111/16 1 3/4 113/16	143	111	23	14	40	19	55,6	51,6	19	M16															33345		
UCFX10 UCFX10-30 UCFX10-31 UCFX10-32	50 17/8 115/16 2	162	130	26	20	44	19	59,4	55,6	22,2	M16	41230	27930	UCX10 UCX10-30 UCX10-31 UCX10-32	FX10	3,9												
UCFX11 UCFX11-33 UCFX11-34 UCFX11-35 UCFX11-36 UCFX11-37	55 21/16 21/8 23/16 2 1/4 25/16	175	143	29	20	49	19	68,7	65,1	25,4	M16			49780			34390	UCX11 UCX11-33 UCX11-34 UCX11-35 UCX11-36 UCX11-37	FX11	4,9								
UCFX12 UCFX12-38 UCFX12-39	60 23/8 27/16	187	149	34	21	59	19	73,7	65,1	25,4	M16							54340			38095	UCX12 UCX12-38 UCX12-39	FX12	5,2				
UCFX13 UCFX13-40 UCFX13-41	65 2 1/2 29/16	187	149	34	21	59	19	78,4	74,6	30,2	M16	59090	41895	UCX13 UCX13-40 UCX13-41	FX13	5,3												
UCFX14 UCFX14-42 UCFX14-43 UCFX14-44	70 25/8 211/16 2 3/4	197	152	37	24	60	23	81,5	77,8	33,3	M20			64030			45885		UCX14 UCX14-42 UCX14-43 UCX14-44	FX14		7,3						
UCFX15 UCFX15-45 UCFX15-46 UCFX15-47 UCFX15-48	75 213/16 27/8 215/16 3	197	152	40	24	68	23	89,3	82,6	33,3	M20								69065						50350	UCX15 UCX15-45 UCX15-46 UCX15-47 UCX15-48	FX15	8,1
UCFX16 UCFX16-49 UCFX16-50 UCFX16-51 UCFX16-52	80 31/16 31/8 33/16 3 3/4	214	171	40	24	70	23	91,6	85,7	34,1	M20	79800	58805	UCX16 UCX16-49 UCX16-50 UCX16-51 UCX16-52	FX16	9,9												
UCFX17 UCFX17-53 UCFX17-55	85 35/16 37/16	214	171	40	24	70	23	93,3	96	39,7	M20			91295			67925	UCX17 UCX17-53 UCX17-55		FX17	11							
UCFX18 UCFX18-56 UCFX18-57	90 37/16 3 1/2	214	171	45	24	76	23	106,1	104	42,9	M20							103550				77805	UCX18 UCX18-56 UCX18-57	FX18		11		
UCFX20 UCFX20-58 UCFX20-59 UCFX20-60 UCFX20-61	100 313/16 37/8 315/16 4	268	211	59	31	97	31	127,3	117,5	49,2	M27	126350	99750	UCX20 UCX20-58 UCX20-59 UCX20-60 UCX20-61	FX20	17												

UKF2 Serie normal - Standard duty

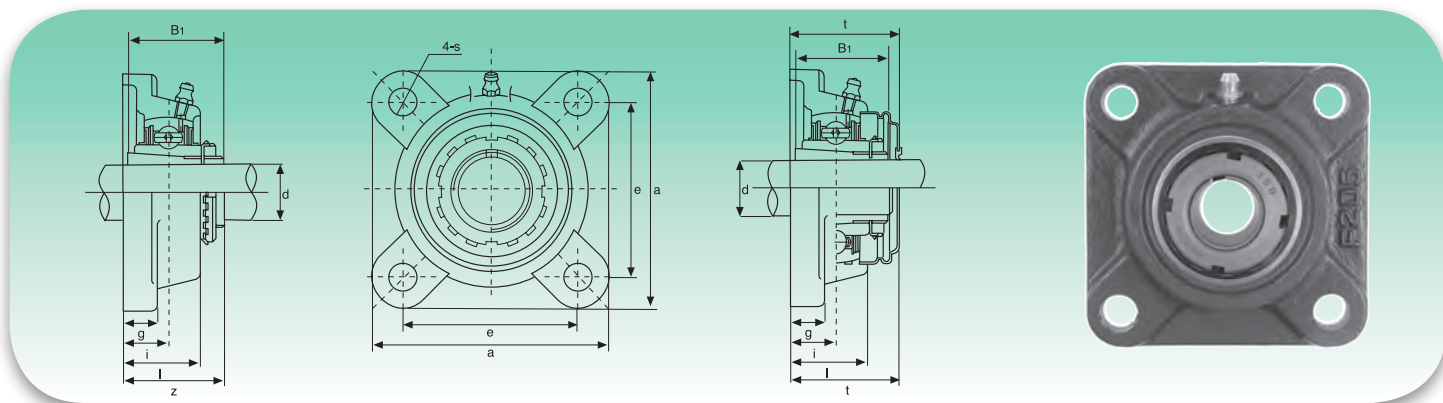

Tipo Type	Dimensiones - Dimensions										Bul. fj. Bolt Size	Coeficientes de carga (N) Load ratings (N)		Rodamiento Bearing	Soporte Housing	Peso Weight
	d	a	e	i	g	l	s	z	t	B ₁		Dinámica C Dynamic C	Estática C ₀ Static C ₀			
	mm/inch											mm/inch				
UKF205+H2305 UKF205+HE2305	20 ¾	95 3¾	70 2¾	16 5/8	14 35/64	27 11/16	12 15/32	35,5 125/64	40 19/16	35 1,378	M10 3/8	13300	7457	UK205+H2305 UK205+HE2305	F205	0,85
UKF206+H2306 UKF206+HS2306 UKF206+HE2306	25 7/8 1	108 4¼	83 317/64	18 45/64	14 35/64	31 17/32	12 15/32	39 117/32	44,5 1¾	38 1,496	M10 3/8	18525	10735	UK206+H2306 UK206+HS2306 UK206+HE2306	F206	1,16
UKF207+H2307 UKF207+HS2307	30 11/8	117 439/64	92 35/8	19 ¾	16 5/8	34 111/32	14 35/64	42,5 143/64	48,5 129/32	43 1,693	M12 7/16	24415	14630	UK207+H2307 UK207+HS2307	F207	1,55
UKF208+H2308 UKF208+HE2308 UKF208+HS2308	35 1¼ 13/8	130 51/8	102 41/64	21 53/64	16 5/8	36 127/64	16 5/8	46,5 153/64	55,5 23/16	46 1,811	M14 ½	27645	16910	UK208+H2308 UK208+HE2308 UK208+HS2308	F208	1,94
UKF209+H2309 UKF209+HA2309 UKF209+HE2309 UKF209+HS2309	40 17/16 1½ 15/8	137 513/32	105 49/64	22 55/64	18 23/32	38 1½	16 5/8	48,5 129/32	56,5 27/32	50 1,969	M14 ½	32395	20235	UK209+H2309 UK209+HA2309 UK209+HE2309 UK209+HS2309	F209	2,30
UKF210+H2310 UKF210+HS2310 UKF210+HA2310 UKF210+HE2310	45 15/8 111/16 1¾	143 55/8	111 43/8	22 55/64	18 23/32	40 19/16	16 5/8	50 131/32	59,5 211/32	55 2,165	M14 ½	33345	22135	UK210+H2310 UK210+HS2310 UK210+HA2310 UK210+HE2310	F210	2,59
UKF211+H2311 UKF211+HS2311 UKF211+HA2311 UKF211+HE2311	50 17/8 115/16 2	162 63/8	130 51/8	25 63/64	20 25/32	43 111/16	19 ¾	54,5 29/64	63 231/64	59 2,323	M16 5/8	41230	27930	UK211+H2311 UK211+HS2311 UK211+HA2311 UK211+HE2311	F211	3,46
UKF212+H2312 UKF212+HS2312	55 21/8	175 657/64	143 55/8	29 19/64	20 25/32	48 157/64	19 ¾	61 219/32	73,5 257/64	62 2,441	M16 5/8	49780	34390	UK212+H2312 UK212+HS2312	F212	4,33
UKF213+H2313 UKF213+HA2313 UKF213+HE2313 UKF213+HS2313	60 23/16 2¼ 23/8	187 723/64	149 555/64	30 13/16	22 55/64	50 131/32	19 ¾	64 233/64	74,5 215/16	65 2,559	M16 5/8	54340	38095	UK213+H2313 UK213+HA2313 UK213+HE2313 UK213+HS2313	F213	4,90
UKF215+H2315 UKF215+HA2315 UKF215+HE2315	65 27/16 2½	200 77/8	159 617/64	34 111/32	22 55/64	56 27/32	19 ¾	71 251/64	83,5 39/32	73 2,874	M16 5/8	64030	45885	UK215+H2315 UK215+HA2315 UK215+HE2315	F215	7,02
UKF216+H2316 UKF216+HA2316 UKF216+HE2316	70 211/16 2¾	208 83/16	165 6½	34 111/32	22 55/64	58 29/32	23 29/32	73,5 257/64	88,5 331/64	78 3,071	M20 ¾	69065	50350	UK216+H2316 UK216+HA2316 UK216+HE2316	F216	7,76
UKF217+H2317 UKF217+HA2317 UKF217+HE2317	75 215/16 3	220 821/32	175 657/64	36 127/64	24 15/16	63 215/32	23 29/32	77 31/32	92,6 341/64	82 3,228	M20 ¾	79800	58805	UK217+H2317 UK217+HA2317 UK217+HE2317	F217	10,08
UKF218+H2318 UKF218+HA2318	80 33/16	235 9¼	187 723/64	40 137/64	24 15/16	68 211/16	23 29/32	81,5 313/64	101,5 4	86 3,386	M20 ¾	91295	67925	UK218+H2318 UK218+HA2318	F218	12,44

Manguitos HA; HE; HS con rosca en pulgadas
Inch dimension adapter sleeves HA; HE; HS

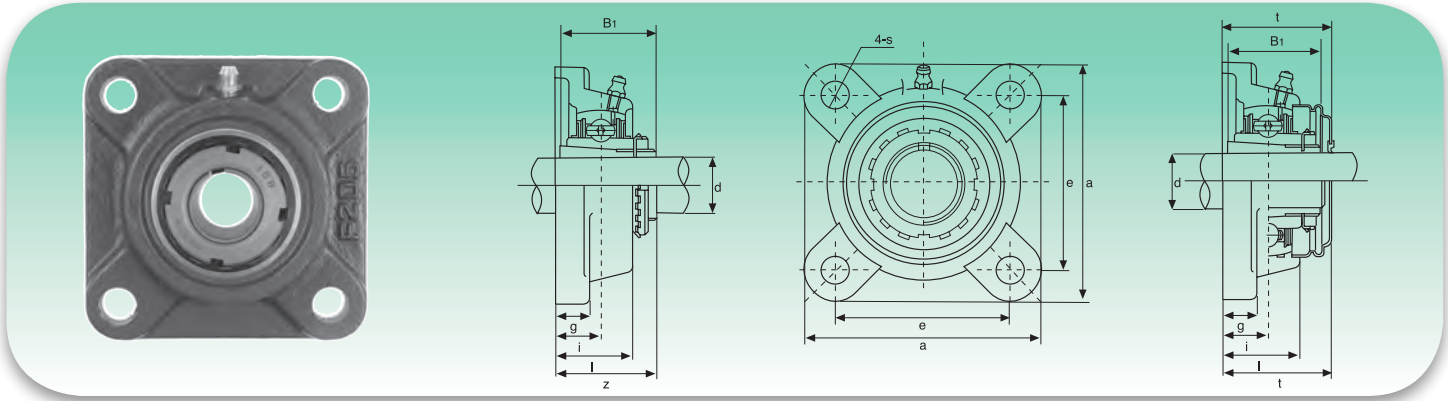
UKF3 Serie pesada - Heavy duty

Tipo Type	Dimensiones - Dimensions									Bul. fij. Bolt Size	Coeficientes de carga (N) Load ratings (N)		Rodamiento Bearing	Soporte Housing	Peso Weight kg
	d	a	e	i	g	l	s	z	B ₁		Dinámica C Dynamic C	Estática C ₀ Static C ₀			
	mm/inch														
UKF305+H2305 UKF305+HE2305	20 ¾	110 411/32	80 35/32	16 5/8	13 ½	29 15/32	16 5/8	37 129/64	35 1,378	M14 ½	20140	10355	UK305+H2305 UK305+HE2305	F305	1,4
UKF306+H2306 UKF306+HS2306 UKF306+HE2306	25 7/8 1	125 429/32	95 347/64	18 45/64	15 19/32	32 1¼	16 5/8	40,5 219/32	38 1,496	M14 ½	25365	14250	UK306+H2306 UK306+HS2306 UK306+HE2306	F306	1,9
UKF307+H2307 UKF307+HS2307	30 11/8	135 55/16	100 315/16	20 25/32	16 5/8	36 113/32	19 ¾	44,5 2¾	43 1,693	M16 5/8	31730	18335	UK307+H2307 UK307+HS2307	F307	2,3
UKF308+H2308 UKF308+HE2308 UKF308+HS2308	35 1¼ 13/8	150 529/32	112 413/32	23 29/32	17 21/32	40 19/16	19 ¾	50 231/32	46 1,811	M16 5/8	38665	22800	UK308+H2308 UK308+HE2308 UK308+HS2308	F308	3,1
UKF309+H2309 UKF309+HA2309 UKF309+HE2309 UKF309+HS2309	40 17/16 1½ 15/8	160 61/16	125 459/64	25 63/64	18 23/32	44 123/32	19 ¾	54,5 29/64	50 1,969	M16 5/8	46455	28025	UK309+H2309 UK309+HA2309 UK309+HE2309 UK309+HS2309	F309	4,1
UKF310+H2310 UKF310+HS2310 UKF310+HA2310 UKF310+HE2310	45 15/8 111/16 1¾	175 67/8	132 513/64	28 17/64	19 ¾	48 17/8	23 29/32	60 223/64	55 2,165	M20 ¾	58900	36385	UK310+H2310 UK310+HS2310 UK310+HA2310 UK310+HE2310	F310	5,1
UKF311+H2311 UKF311+HS2311 UKF311+HA2311 UKF311+HE2311	50 17/8 115/16 2	185 79/32	140 533/64	30 13/16	20 25/32	52 21/16	23 29/32	63,5 2½	59 2,323	M20 ¾	68020	42750	UK311+H2311 UK311+HS2311 UK311+HA2311 UK311+HE2311	F311	5,9
UKF312+H2312 UKF312+HS2312	55 21/8	195 711/16	150 529/32	33 119/64	22 7/8	56 27/32	23 29/32	69 223/32	62 2,441	M20 ¾	77805	49590	UK312+H2312 UK312+HS2312	F312	6,8
UKF313+H2313 UKF313+HA2313 UKF313+HE2313 UKF313+HS2313	60 23/16 2¼ 23/8	208 83/16	166 617/32	33 119/64	22 7/8	58 29/32	23 29/32	71 251/64	65 2,559	M20 ¾	88065	56905	UK313+H2313 UK313+HA2313 UK313+HE2313 UK313+HS2313	F313	7,9
UKF315+H2315 UKF315+HA2315 UKF315+HE2315	65 27/16 2½	236 99/32	184 7¼	39 117/32	25 63/64	66 219/32	25 63/64	81 33/16	73 2,874	M22 7/8	107350	73340	UK315+H2315 UK315+HA2315 UK315+HE2315	F315	11,7
UKF316+H2316 UKF316+HA2316 UKF316+HE2316	70 211/16 2¾	250 927/32	196 723/32	38 1½	27 11/16	68 211/16	31 17/32	83,5 39/32	78 3,071	M27 1	116850	82365	UK316+H2316 UK316+HA2316 UK316+HE2316	F316	12,9
UKF317+H2317 UKF317+HA2317 UKF317+HS2317	75 215/16 3	260 10¼	204 81/32	44 147/64	27 11/16	74 229/32	31 35/8	92 35/8	82 3,228	M27 1	126350	91960	UK317+H2317 UK317+HA2317 UK317+HS2317	F317	15,2
UKF318+H2318 UKF318+HA2318	80 33/16	280 111/32	216 8½	44 147/64	30 13/16	76 3	35 13/8	93,5 311/16	86 3,386	M30 11/8	135850	101650	UK318+H2318 UK318+HA2318	F318	19
UKF319+H2319 UKF319+HA2319	85 35/16	290 1113/32	228 831/32	59 221/64	30 13/16	94 311/16	35 13/8	111 43/8	90 3,543	M30 11/8	145350	113050	UK319+H2319 UK319+HA2319	F319	21,9
UKF320+H2320 UKF320+HA2320	90 37/16	310 127/32	242 917/32	59 221/64	32 1¼	94 311/16	38 1½	115 417/32	97 3,814	M33 1¼	164350	133950	UK320+H2320 UK320+HA2320	F320	25,4
UKF322+H2322 UKF322+HA2322	100 315/16	340 133/8	266 1015/32	60 323/64	35 13/8	96 325/32	41 139/64	121 449/64	105 4,134	M36 13/8	194750	171000	UK322+H2322 UK322+HA2322	F322	35,2
UKF324+H2324 UKF324+HA2324	110 43/16	370 165/32	290 1219/32	65 29/16	40 19/16	110 411/32	41 139/64	130 51/8	112 4,410	M36 13/8	196650	175750	UK324+H2324 UK324+HA2324	F324	47,6
UKF326+H2326 UKF326+HA2326	115 47/16	410 165/32	320 1219/32	65 29/6	45 125/32	115 417/32	41 139/64	134 59/32	121 4,764	M36 13/8	217550	203300	UK326+H2326 UK326+HA2326	F326	65,3
UKF328+H2328 UKF328+HA2328	125 415/16	450 1723/32	350 1325/32	75 261/64	55 25/32	125 429/32	41 139/64	148 553/64	131 5,158	M36 13/8	240350	233700	UK328+H2328 UK328+HA2328	F328	93,4

Manguitos HA; HE; HS con rosca en pulgadas
Inch dimension adapter sleeves HA; HE; HS

UKFX Serie media - Medium duty

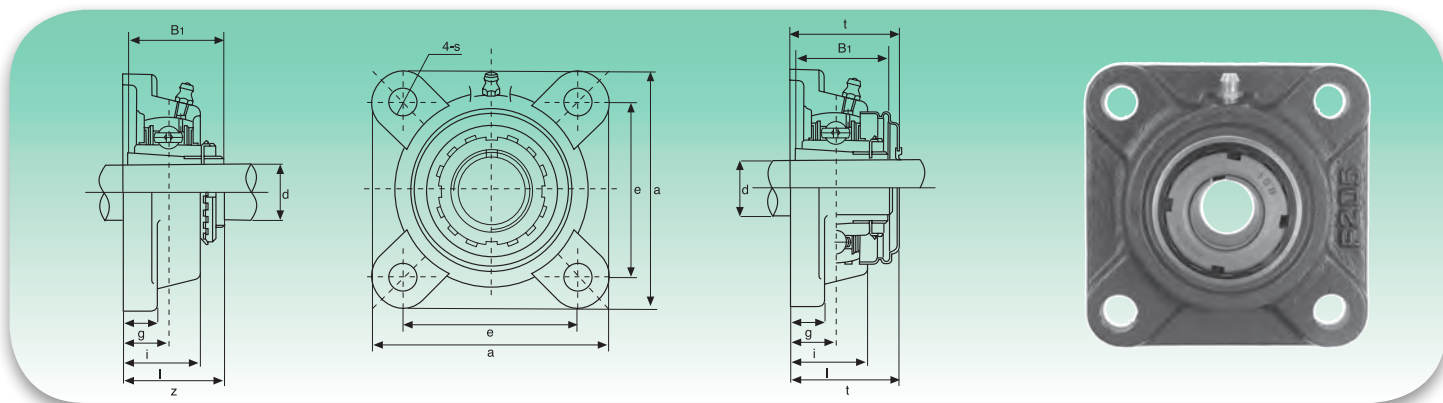

Tipo Type	Dimensiones - Dimensions									Bul. fij. Bolt Size	Coeficientes de carga (N) Load ratings (N)		Rodamiento Bearing	Soporte Housing	Peso Weight
	d	a	e	i	g	l	s	z	B ₁		Dinámica C Dynamic C	Estática C ₀ Static C ₀			
	mm/inch										mm/inch				
UKFX05+H2305	20	108	83	18	13	30	12	39	35	M10			UKX05+H2305	FX05	1,2
UKFX05+HE2305	¾	4¼	317/64	45/64	½	13/16	15/32	117/32	1,378	3/8	18525	10735	UKX05+HE2305		
UKFX06+H2306	25	117	92	19	14	34	16	41,5	38	M14			UKX06+H2306	FX06	1,6
UKFX06+HS2306	7/8										24415	14630	UKX06+HS2306		
UKFX06+HE2306	1	439/64	35/8	¾	9/16	111/32	5/8	141/64	1,496	½			UKX06+HE2306		
UKFX07+H2307	30	130	102	21	14	38	16	45,5	43	M14			UKX07+H2307	FX07	2,0
UKFX07+HS2307	11/8	51/8	41/64	53/64	9/16	1½	5/8	151/64	1,693	½	27645	16910	UKX07+HS2307		
UKFX08+H2308	35	137	105	22	14	40	19	47,5	46	M16			UKX08+H2308	FX08	2,3
UKFX08+HE2308	1¼										32395	20235	UKX08+HE2308		
UKFX08+HS2308	13/8	513/32	49/64	55/64	9/16	19/16	¾	17/8	1,811	5/8			UKX08+HS2308		
UKFX09+H2309	40	143	111	23	14	40	19	50	50	M16			UKX09+H2309	FX09	2,7
UKFX09+HA2309	15/8										33345	22135	UKX09+HA2309		
UKFX09+HE2309	1½	55/8	43/8	29/32	9/16	19/16	¾	131/32	1,969	5/8			UKX09+HE2309		
UKFX09+HS2309	15/8												UKX09+HS2309		
UKFX10+H2310	45	162	130	26	20	44	19	55,5	55	M16			UKX10+H2310	FX10	3,6
UKFX10+HS2310	15/8										41230	27930	UKX10+HS2310		
UKFX10+HA2310	111/16	63/8	51/8	11/32	25/32	123/32	¾	23/16	2,165	5/8			UKX10+HA2310		
UKFX10+HE2310	1¾												UKX10+HE2310		
UKFX11+H2311	50	175	143	29	20	49	19	60	59	M16			UKX11+H2311	FX11	4,6
UKFX11+HS2311	17/8										49780	34390	UKX11+HS2311		
UKFX11+HA2311	115/16	657/64	55/8	19/64	25/32	115/16	¾	223/64	2,323	5/8			UKX11+HA2311		
UKFX11+HE2311	2												UKX11+HE2311		
UKFX12+H2312	55	187	149	34	21	59	19	67	62	M16			UKX12+H2312	FX12	5,5
UKFX12+HS2312	21/8	723/64	555/64	111/32	13/16	25/16	¾	241/64	2,441	5/8	54340	38095	UKX12+HS2312		
UKFX13+H2313	60	187	149	34	21	59	19	68	65	M16			UKX13+H2313	FX13	6,0
UKFX13+HA2313	23/16										59090	41895	UKX13+HA2313		
UKFX13+HE2313	2¼	723/64	555/64	111/32	13/16	25/16	¾	211/16	2,559	5/8			UKX13+HE2313		
UKFX13+HS2313	23/8												UKX13+HS2313		
UKFX15+H2315	65	197	152	40	24	68	23	77,5	73	M20			UKX15+H2315	FX15	8,1
UKFX15+HA2315	27/16										69065	50350	UKX15+HA2315		
UKFX15+HS2315	2½	7¾	563/64	137/64	15/16	211/16	29/32	23/64	2,874	¾			UKX15+HS2315		
UKFX16+H2316	70	214	171	40	24	70	23	80	78	M20			UKX16+H2316	FX16	9,5
UKFX16+HA2316	211/16										79800	58805	UKX16+HA2316		
UKFX16+HS2316	2¾	87/16	647/64	137/64	15/16	2¾	29/32	35/32	3,071	¾			UKX16+HS2316		
UKFX17+H2317	75	214	171	40	24	70	23	81,5	82	M20			UKX17+H2317	FX17	10,4
UKFX17+HA2317	215/16										91295	67925	UKX17+HA2317		
UKFX17+HE2317	3	87/16	647/64	137/64	15/16	2¾	29/32	3,228	3¾	¾			UKX17+HE2317		
UKFX18+H2318	80	214	171	45	24	76	23	88	86	M20			UKX18+H2318	FX18	11,4
UKFX18+HA2318	33/16	87/16	647/64	149/64	15/16	3	29/32	315/32	3,386	¾	103550	77805	UKX18+HA2318		
UKFX20+H2320	90	268	211	59	31	97	31	106	97	M27			UKX20+H2320	FX20	18,4
UKFX20+HA2330	3½	109/16	85/16	221/64	17/32	313/13	17/32	43/64	3,814	1	126350	99750	UKX20+HA2330		

Manguitos HA; HE; HS con rosca en pulgadas
Inch dimension adapter sleeves HA; HE; HS

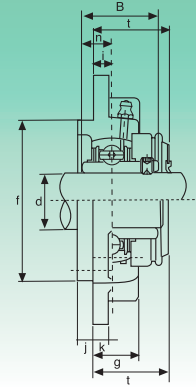
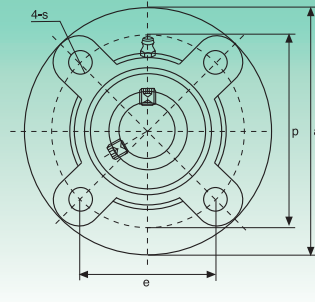
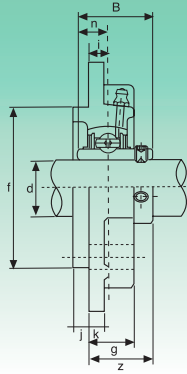

Tipo Type	Dimensiones - Dimensions													Bul. fij. Bolt Size	Coeficientes de carga (N) Load ratings (N)		Rodamiento Bearing	Soporte Housing	Peso Weight		
	d	a	p	e	i	s	j	k	g	f	z	t	B		n	Dinámica C Dynamic C				Estática C ₀ Static C ₀	kg
	mm/inch														mm/inch						
UCFC201 UCFC201-8	12 ¾	100 315/16	78 35/64	55,1 211/64	10 25/64	12 15/32	5 13/64	7 9/32	20,5 13/16	62 2,4409	28,3 11/8	32,5 19/32	31 1,2205	12,7 0,500	M10 3/8	12160	6318	UC201 UC201-8	FC204	0,73 0,72	
UCFC202 UCFC202-9 UCFC202-10	15 9/16 5/8	100 315/16	78 35/64	55,1 211/64	10 25/64	12 15/32	5 13/64	7 9/32	20,5 13/16	62 2,4409	28,3 11/8	32,5 19/32	31 1,2205	12,7 0,500	M10 3/8	12160	6318	UC202 UC202-9 UC202-10	FC204	0,72 0,72 0,72	
UCFC203 UCFC203-11	17 11/16	100 315/16	78 35/64	55,1 211/64	10 25/64	12 15/32	5 13/64	7 9/32	20,5 13/16	62 2,4409	28,3 11/8	32,5 19/32	31 1,2205	12,7 0,500	M10 3/8	12160	6318	UC203 UC203-11	FC204	0,71 0,70	
UCFC204 UCFC204-12	20 ¾	100 315/16	78 35/64	55,1 211/64	10 25/64	12 15/32	5 13/64	7 9/32	20,5 13/16	62 2,4409	28,3 11/8	32,5 19/32	31 1,2205	12,7 0,500	M10 3/8	12160	6318	UC204 UC204-12	FC204	0,69 0,69	
UCFC205 UCFC205-13 UCFC205-14 UCFC205-15 UCFC205-16	25 13/16 7/8 15/16 1	115 417/32	90 335/64	63,6 2 ½	10 25/64	12 15/32	8 15/64	8 9/32	23 53/64	80 2,7559	32,2 111/64	36,5 111/32	15,9 1,3425	14,3 0,563	M10 3/8	13300	7457	UC205 UC205-13 UC205-14 UC205-15 UC205-16	FC205	1,00 1,04 1,03 1,01 1,00	
UCFC206 UCFC206-17 UCFC206-18 UCFC206-19 UCFC206-20	30 11/16 1 1/8 13/16 1 ¼	125 459/64	100 315/16	70,7 225/32	10 25/64	12 15/32	8 5/16	8 5/16	23 29/32	80 3,1496	32,2 117/64	36,5 17/16	15,9 1,5000	14,3 0,626	M10 3/8	18525	10735	UC206 UC206-17 UC206-18 UC206-19 UC206-20	FC206	1,30 1,31 1,32 1,30 1,29	
UCFC207 UCFC207-20 UCFC207-21 UCFC207-22 UCFC207-23	35 1 ¼ 15/16 13/8 17/16	135 55/16	110 421/64	77,8 31/16	11 7/16	14 35/64	8 5/16	9 23/64	26 11/32	100 3,5433	41,2 17/16	45,5 15/8	19 1,6890	17,5 0,689	M12 7/16	24415	14630	UC207 UC207-20 UC207-21 UC207-22 UC207-23	FC207	1,81 1,87 1,84 1,81 1,78	
UCFC208 UCFC208-24 UCFC208-25	40 1 ½ 19/6	145 545/64	120 423/32	84,8 321/16	11 7/16	14 35/64	10 25/64	9 23/84	26 11/32	100 3,9370	41,2 15/8	45,5 151/64	19 1,9370	17,5 0,748	M12 7/16	27645	16910	UC208 UC208-24 UC208-25	FC208	2,14 2,18 2,15	
UCFC209 UCFC209-26 UCFC209-27 UCFC209-28	45 15/8 111/64 1 ¾	160 619/64	132 513/64	93,3 343/64	10 25/64	16 5/8	12 15/32	14 35/64	26 11/32	105 4,1339	40,2 137/64	44,5 1 ¾	19 1,9370	17,5 0,748	M14 ½	32395	20235	UC209 UC209-26 UC209-27 UC209-28	FC209	2,68 2,78 2,74 2,70	
UCFC210 UCFC210-29 UCFC210-30 UCFC210-31 UCFC210-32	50 113/16 17/8 115/16 2	165 57/16	138 327/32	97,6 25/64	10 5/8	16 15/32	12 35/64	14 17/64	28 4,3307	110 11/16	42,6 17/8	47,5 2,0315	19 0,748	M14 ½	33345	22135	UC210 UC210-29 UC210-30 UC210-31 UC210-32	FC210	2,90 3,02 2,97 2,92 2,88		
UCFC211 UCFC211-32 UCFC211-33 UCFC211-34 UCFC211-35	55 2 21/16 21/8 23/16	185 79/32	150 529/32	106,1 43/16	13 33/64	19 ¾	12 15/32	15 19/32	31 17/32	125 4,9213	46,4 153/64	51 21/64	22,2 2,1890	17,5 0,874	M16 5/8	41230	27930	UC211 UC211-32 UC211-33 UC211-34 UC211-35	FC211	4,01 4,16 4,10 4,05 3,99	
UCFC212 UCFC212-36 UCFC212-37 UCFC212-38 UCFC212-39	60 2 ¼ 25/16 23/8 27/16	195 711/64	160 619/64	113,1 442/64	17 43/64	19 ¾	12 15/32	15 19/32	36 127/64	135 5,3150	56,7 215/64	61,5 227/64	25,4 2,5630	17,5 1,000	M16 5/8	49780	34390	UC212 UC212-36 UC212-37 UC212-38 UC212-39	FC212	4,94 5,07 4,99 4,92 4,85	
UCFC213 UCFC213-40 UCFC213-41	65 2 ½ 29/16	205 85/64	170 611/64	120,2 447/64	16 5/8	19 ¾	14 35/64	15 19/32	36 127/64	145 5,5118	55,7 13/16	60,5 225/64	25,4 2,5630	17,5 1,000	M16 5/8	54340	38095	UC213 UC213-40 UC213-41	FC213	5,65 5,74 5,65	
UCFC214 UCFC214-42 UCFC214-43 UCFC214-44	70 25/8 211/64 2 ¾	215 815/64	177 632/32	125,1 459/64	17 43/64	19 ¾	14 35/64	18 23/32	40 137/64	150 5,9055	61,4 113/32	- 2,9370	30,2 1,189	M16 5/8	59090	41895	UC214 UC214-42 UC214-43 UC214-44	FC214	6,95 7,16 7,06 6,96		
UCFC215 UCFC215-45 UCFC215-46 UCFC215-47 UCFC215-48	75 213/16 27/8 215/16 3	220 831/32	184 7 ¼	130,1 51/8	18 23/32	19 ¾	16 5/8	18 23/32	40 137/64	160 6,2992	62,5 215/32	- 3,0630	33,3 1,311	M16 5/8	64030	45885	UC215 UC215-45 UC215-46 UC215-47 UC215-48	FC215	7,56 7,81 7,70 7,59 7,47		
UCFC216 UCFC216-49 UCFC216-50 UCFC216-51	80 31/16 31/8 33/16	240 929/64	200 77/8	141,4 59/16	18 23/32	23 29/32	16 5/8	18 23/32	42 121/32	170 6,6929	67,3 221/32	- 3,2520	33,3 1,311	M20 ¾	69065	50350	UC216 UC216-49 UC216-50 UC216-51	FC216	9,15 9,28 9,20 9,07		
UCFC217 UCFC217-52 UCFC217-53 UCFC217-55	85 ¾ 35/16 37/16	250 927/32	208 83/16	147,1 551/64	18 23/32	23 29/32	18 23/32	20 25/32	45 125/32	180 7,0866	69,6 2 ¾	- 3,3740	34,1 1,343	M20 ¾	79800	58805	UC217 UC217-52 UC217-53 UC217-55	FC217	10,81 11,03 10,89 10,60		
UCFC218 UCFC218-56	90 ¾	265 107/16	220 821/32	155,5 61/8	22 55/64	23 29/32	18 23/32	20 25/32	50 131/32	190 7,4803	78,3 33/32	- 3,7795	39,7 1,5630	M20 ¾	91295	67925	UC218 UC218-56	FC218	12,96 13,07		

Disponible en acero inox. Soporte: AISI 304 - Rodamiento: AISI 440C - Available stainless steel Housing: AISI 304 - Bearing: AISI 440C
 Disponible bajo demanda con rodamiento SA (SAFC.) - Available under request with SA bearing (SAFC.)

HCFC2 Serie normal - Standard duty

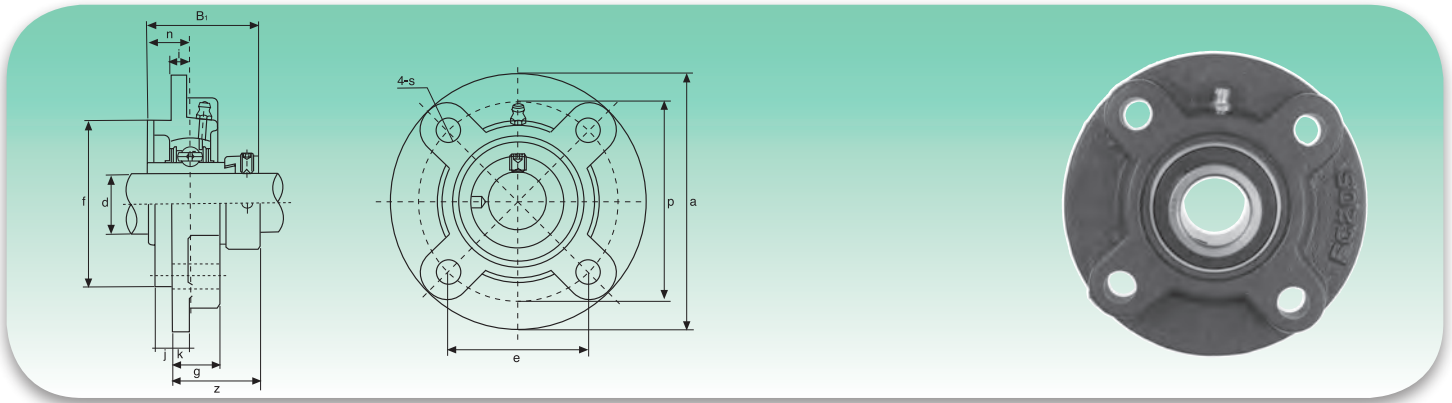

Tipo Type	Dimensiones - Dimensions													Bul. fj. Bolt Size	Coeficientes de carga (N) Load ratings (N)		Rodamiento Bearing	Soporte Housing	Peso Weight	
	d	a	p	e	i	s	j	k	g	f	z	B ₁	n		Dinámica C Dynamic C	Estática C ₀ Static C ₀				kg
	mm/inch																			
HCFC204	12	100	78	55,1	10	12	5	7	20,5	62	36,6	43,7	17,1	M10	12160	6318	HC204	FC204	0,76	
HCFC204-12	¾	315/16	35/64	211/64	25/64	15/32	13/64	9/32	13/16	2,4409	17/16	1,720	0,673	3/8			0,76			
HCFC205	25	115	90	63,6	10	12	6	7	21	70	36,9	44,4	17,5	M10	13300	7457	HC205	FC205	1,07	
HCFC205-13	13/16																1,12			
HCFC205-14	7/8	417/32	335/64	2½	25/64	15/32	15/64	9/32	53/64	2,7559	129/64	1,748	0,689	3/8			1,11			
HCFC205-15	15/16																1,09			
HCFC205-16	1																1,07			
HCFC206	30	125	100	70,7	10	12	8	8	23	80	40,1	48,4	18,3	M10	18525	10735	HC206	FC206	1,43	
HCFC206-17	11/16																1,48			
HCFC206-18	11/8	459/64	315/16	225/32	25/64	15/32	5/16	5/16	29/32	3,1496	137/64	1,906	0,720	3/8			1,45			
HCFC206-19	13/16																1,43			
HCFC206-20	1¼																1,40			
HCFC207	35	135	110	77,8	11	14	8	9	26	90	43,3	51,1	18,8	M12	24415	14630	HC207	FC207	1,93	
HCFC207-20	1¼																2,00			
HCFC207-21	15/16	15/16	421/64	31/16	7/16	35/64	5/16	23/64	11/32	3,5433	145/64	2,012	0,740	7/16			1,96			
HCFC207-22	13/8																1,93			
HCFC207-23	17/16																1,87			
HCFC208	40	145	120	84,8	11	14	10	9	26	100	45,9	56,3	21,4	M12	27645	16910	HC208	FC208	2,29	
HCFC208-24	1½	545/64	423/32	311/32	7/16	35/64	25/64	23/64	11/32	3,9370	113/16	2,217	0,843	7/16			2,34			
HCFC208-25	19/16																2,30			
HCFC209	45	160	132	93,3	10	16	12	14	26	105	44,9	56,3	21,4	M14	32395	20235	HCF209	FC209	2,85	
HCFC209-26	15/8																2,96			
HCFC209-27	111/16	6619/64	513/64	343/64	25/64	5/8	15/32	35/64	11/32	4,1339	149/64	2,217	0,843	½			2,91			
HCFC209-28	1¾																2,87			
HCFC210	50	165	138	97,6	10	16	12	14	28	110	48,1	62,7	24,6	M14	33345	22135	HCF210	FC210	3,09	
HCFC210-29	113/16																3,24			
HCFC210-30	17/8	6½	57/16	327/32	25/64	5/8	15/32	35/94	17/64	4,3307	157/64	2,469	0,969	½			3,18			
HCFC210-31	115/16																3,12			
HCFC210-32	2														3,06					
HCFC211	55	185	150	106,1	13	19	12	15	31	125	56,6	71,4	27,8	M16	41230	27930	HCF211	FC211	4,22	
HCFC211-32	2																4,42			
HCFC211-33	22/16	79/32	529/32	43/16	33/64	¾	15/32	19/32	17/32	4,9213	215/64	2,811	1,094	5/8			4,34			
HCFC211-34	21/8																4,27			
HCFC211-35	23/16																4,19			
HCFC212	60	195	160	113,1	17	19	12	15	36	135	63,8	77,8	31	M16	49780	34390	HC212	FC212	5,28	
HCFC212-36	2¼																5,44			
HCFC212-37	25/16	711/16	619/64	429/64	43/64	¾	15/32	19/32	127/64	5,3150	233/64	3,063	1,220	5/8			5,35			
HCFC212-38	23/8																5,30			
HCFC212-39	27/16																5,17			
HCFC213	65	205	170	120,2	16	19	14	15	36	145	67,6	85,7	34,1	M16	54340	38095	HC213	FC213	6,21	
HCFC213-40	2½	85/64	611/16	447/64	5/8	¾	35/64	19/32	127/64	5,5118	221/32	3,374	1,343	5/8			6,31			
HCFC213-41	29/16																6,20			
HCFC214	70	215	177	125,1	17	19	14	18	40	150	68,6	85,7	34,1	M16	59090	41895	HC214	FC214	7,45	
HCFC214-42	23/8																7,69			
HCFC214-43	211/16	815/32	631/32	459/64	43/64	¾	35/64	23/32	137/64	5,9055	245/64	3,374	1,343	5/8			7,58			
HCFC214-44	2¾																7,46			
HCFC215	75	220	184	130,1	18	19	16	18	40	160	72,8	92,1	37,3	M16	64030	45885	HC215	FC215	8,19	
HCFC215-45	213/16																8,49			
HCFC215-46	27/8	821/32	7¼	51/8	23/32	¾	5/8	23/32	137/64	6,2992	27/8	3,626	1,469	5/8			8,36			
HCFC215-47	215/16																8,23			
HCFC215-48	3																8,09			

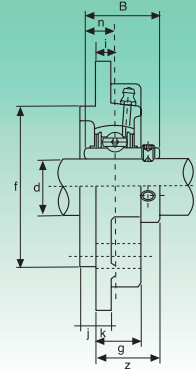
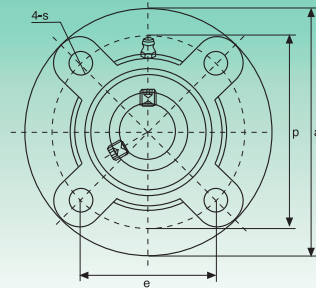

Tipo Type	Dimensiones - Dimensions													Bul. fij. Bolt Size	Coeficientes de carga (N) Load ratings (N)		Rodamiento Bearing	Soporte Housing	Peso Weight kg															
	d	a	p	e	i	s	j	k	g	f	z	B	n		Dinámica C Dynamic C	Estática C ₀ Static C ₀																		
	mm/inch														mm/inch																			
UCFCX05 UCFCX05-13 UCFCX05-14 UCFCX05-15 UCFCX05-16	25 13/16 7/8 15/16 1	111	92	65	10	9,5	6	9,5	24	76	32,2	38,1	15,9	M8	18525	10735	UCX05 UCX05-13 UCX05-14 UCX05-15 UCX05-16	FCX05	1,2															
UCFCX06 UCFCX06-17 UCFCX06-18 UCFCX06-19 UCFCX06-20	30 11/16 11/8 13/16 1 1/4	127	105	74,2	8	12	9,5	9,5	22,5	85	33,4	42,9	17,5	M10						24415	14630	UCX06 UCX06-17 UCX06-18 UCX06-19 UCX06-20	FCX06	1,5										
UCFCX07 UCFCX07-21 UCFCX07-22 UCFCX07-23	35 15/16 13/8 17/16	133	111	78,5	9	12	11	11	26	92	39,2	49,2	19	M10											27645	16910	UCX07 UCX07-21 UCX07-22 UCX07-23	FCX07	1,9					
UCFCX08 UCFCX08-24 UCFCX08-25	40 1 1/2 19/16	133	111	78,5	9	12	11	11	26	92	39,2	49,2	19	M10																32395	20235	UCX08 UCX08-24 UCX08-25	FCX08	2,0
UCFCX09 UCFCX09-26 UCFCX09-27 UCFCX09-28 UCFCX09-29	45 15/8 111/16 1 3/4 113/16	155	130	91,9	8	14	12	11	25	108	40,6	51,6	19	M12																				
UCFCX10 UCFCX10-30 UCFCX10-31 UCFCX10-32	50 17/8 115/16 2	162	136	96,2	7	14	16	11	25	118	40,4	55,6	22,2	M12	41230	27930	UCX10 UCX10-30 UCX10-31 UCX10-32	FCX10	3,2															
UCFCX11 UCFCX11-33 UCFCX11-34 UCFCX11-35 UCFCX11-36 UCFCX11-37	55 21/16 21/8 23/16 2 1/4 25/16	180	152	107,5	4	16	22	13	26	127	43,7	65,1	25,4	M14						49780	34390	UCX11 UCX11-33 UCX11-34 UCX11-35 UCX11-36 UCX11-37	FCX11	4,3										
UCFCX12 UCFCX12-38 UCFCX12-39	60 23/8 27/16	194	165	116,7	11	16	20	14	33	140	50,7	65,1	25,4	M14											54340	38095	UCX12 UCX12-38 UCX12-39	FCX12	5,3					
UCFCX13 UCFCX13-40 UCFCX13-41	65 2 1/2 29/16	194	165	116,7	11	16	20	14	33	140	55,4	74,6	30,2	M14																59090	41895	UCX13 UCX13-40 UCX13-41	FCX13	5,7
UCFCX14 UCFCX14-42 UCFCX14-43 UCFCX14-44	70 25/8 21/16 2 3/4	222	190	134,3	14	19	20	14	36	164	58,5	77,8	33,3	M16																				
UCFCX15 UCFCX15-45 UCFCX15-46 UCFCX15-47 UCFCX15-48	75 213/16 27/8 215/16 3	222	190	134,3	12	19	22	16	35	164	61,3	82,6	33,3	M16	69065	50350	UCX15 UCX15-45 UCX15-46 UCX15-47 UCX15-48	FCX15	8															
UCFCX16 UCFCX16-49 UCFCX16-50 UCFCX16-51 UCFCX16-52	80 31/16 31/8 33/16 3 1/4	260	219	154,8	10	23	25	19	36	186	61,6	85,7	34,1	M20						79800	58805	UCX16 UCX16-49 UCX16-50 UCX16-51 UCX16-52	FCX16	11,3										
UCFCX17 UCFCX17-53 UCFCX17-55	85 35/16 37/16	260	219	154,8	10	23	25	19	36	186	66,3	96	39,7	M20											91295	67925	UCX17 UCX17-53 UCX17-55	FCX17	12,9					
UCFCX18 UCFCX18-56 UCFCX18-57	90 37/16 3 1/2	260	219	154,8	12	23	28	-	43	186	73,1	104	42,9	M20																103550	77805	UCX18 UCX18-56 UCX18-57	FCX18	12
UCFCX20 UCFCX20-58 UCFCX20-59 UCFCX20-60 UCFCX20-61	100 313/16 37/8 315/16 4	276	238	168,3	22	23	28	-	66	206	90,3	117,5	49,2	M20																				

UKFC2 Serie normal - Standard duty

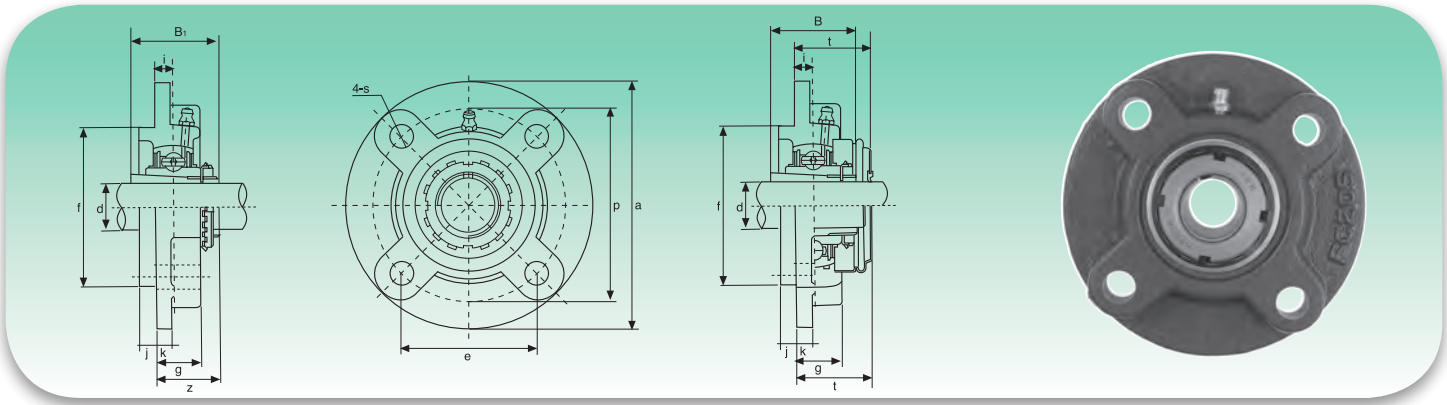

Tipo Type	Dimensiones - Dimensions													Bul. fij. Bolt Size	Coeficientes de carga (N) Load ratings (N)		Rodamiento Bearing	Soporte Housing	Peso Weight	
	d	a	p	e	i	s	j	k	g	f	z	t	B ₁		Dinámica C Dynamic C	Estática C ₀ Static C ₀				kg
	mm/inch														mm/inch					
UKFC205+H2305	20	115	90	63,6	10	12	6	7	21	70	29,5	34	35	M10	13300	7457	UK205+H2305	FC205	1,05	
UKFC205+HE2305	¾	417/32	335/64	2½	15/64	15/32	15/64	9/32	53/64	2,7559	15/32	111/32	1,378	3/8			UK205+HE2305			
UKFC206+H2306	25	125	100	70,7	10	12	8	8	23	80	31	36,5	38	M10	18525	10735	UK206+H2306	FC206	1,34	
UKFC206+HS2306	7/8	459/64	315/16	225/32	25/64	15/32	5/16	5/16	29/32	3,1496	17/32	17/16	1,496	3/8			UK206+HS2306			UK206+HE2306
UKFC206+HE2306	1																			
UKFC207+H2307	30	135	110	77,8	11	14	8	9	26	90	33,5	41	43	M12	24415	14630	UK207+H2307	FC207	1,90	
UKFC207+HS2307	11/8	55/6	421/64	31/16	7/16	35/64	5/16	23/64	11/32	3,5433	15/16	15/8	1,693	7/16			UK207+HS2307			
UKFC208+H2308	35	145	120	84,8	11	14	10	9	26	100	35,5	45,5	46	M12	27645	16910	UK208+H2308	FC208	2,24	
UKFC208+HE2308	1¼	545/64	423/32	311/32	7/16	35/64	25/64	23/64	11/32	3,9370	125/64	151/64	1,811	7/16			UK208+HE2308			UK208+HS2308
UKFC208+HS2308	13/8																			
UKFC209+H2309	40	160	132	93,3	10	16	12	14	26	105	36	44,5	50	M14	32395	20235	UK209+H2309	PFC209	2,83	
UKFC209+HA2309	17/16																UK209+HA2309			UK209+HE2309
UKFC209+HE2309	1½	619/64	513/64	343/64	25/64	5/8	15/32	35/64	11/32	4,1339	127/64	1¾	1,969	½						
UKFC209+HS2309	15/8																			
UKFC210+H2310	45	165	138	97,6	10	16	12	14	28	110	37,5	47,5	55	M14	33345	22135	UK210+H2310	FC210	3,07	
UKFC210+HS2310	15/8																UK210+HS2310			UK210+HA2310
UKFC210+HA2310	111/16	6½	57/16	327/32	25/64	5/8	15/32	35/64	17/64	4,3307	115/32	17/8	2,165	½						
UKFC210+HE2310	1¾																			
UKFC211+H2311	50	185	150	106,1	13	19	12	15	31	125	41,5	51	59	M16	41230	27930	UK211+H2311	FC211	4,16	
UKFC211+HS2311	17/8																UK211+HS2311			UK211+HA2311
UKFC211+HA2311	115/16	79/32	529/32	43/16	33/64	¾	15/32	19/32	17/32	4,9213	141/64	21/64	2,323	5/8						
UKFC211+HE2311	2																			
UKFC212+H2312	55	195	160	113,1	17	19	12	15	36	135	48	61,5	62	M16	49780	34390	UK212+H2312	FC212	4,99	
UKFC212+HS2312	21/8	711/16	619/64	429/64	43/64	¾	15/32	19/32	127/64	5,3150	157/64	227/64	2,441	5/8			UK212+HS2312			
UKFC213+H2313	60	205	170	120,2	16	19	14	15	36	145	49	60,5	65	M16	54340	38095	UK213+H2313	FC213	5,56	
UKFC213+HA2313	23/16																UK213+HA2313			UK213+HE2313
UKFC213+HE2313	2¼	85/64	611/16	447/64	5/8	¾	35/64	19/32	127/64	5,5118	115/16	225/64	2,559	5/8						
UKFC213+HS2313	23/8																			
UKFC215+H2315	65	220	184	130,1	18	19	16	18	40	160	53,5	-	73	M16	64030	45885	UK215+H2315	FC215	7,67	
UKFC215+HA2315	27/16																UK215+HA2315			UK215+HE2315
UKFC215+HE2315	2½	821/32	7¼	51/8	23/32	¾	5/8	23/32	137/64	6,2992	27/64	-	2,874	5/8						
UKFC216+H2316	70	240	200	141,4	18	23	16	18	42	170	57	-	78	M20	69065	50350	UK216+H2316	FC216	9,41	
UKFC216+HA2316	211/16																UK216+HA2316			UK216+HE2316
UKFC216+HE2316	2¾	929/64	77/8	59/16	23/32	29/32	5/8	23/32	121/32	6,6929	2¼	-	3,071	¾						
UKFC217+H2317	75	250	208	147,1	18	23	18	20	45	180	59	-	82	M20	79800	58805	UK217+H2317	FC217	11,23	
UKFC217+HA2317	215/16																UK217+HA2317			UK217+HE2317
UKFC217+HE2317	3	927/32	83/16	551/64	23/32	29/32	23/32	25/32	125/32	7,0866	221/64	-	3,228	¾						
UKFC218+H2318	80	265	220	155,5	22	23	18	20	50	190	64,5	-	86	M20	91295	67925	UK218+H2318	FC218	13,34	
UKFC218+HA2318	33/16	107/16	821/32	61/8	55/64	29/32	23/32	25/32	131/32	7,4803	335/64	-	3,386	¾			UK218+HA2318			

Manguitos HA; HE; HS con rosca en pulgadas
Inch dimension adapter sleeves HA; HE; HS

HCFL2 Serie normal - Standard duty

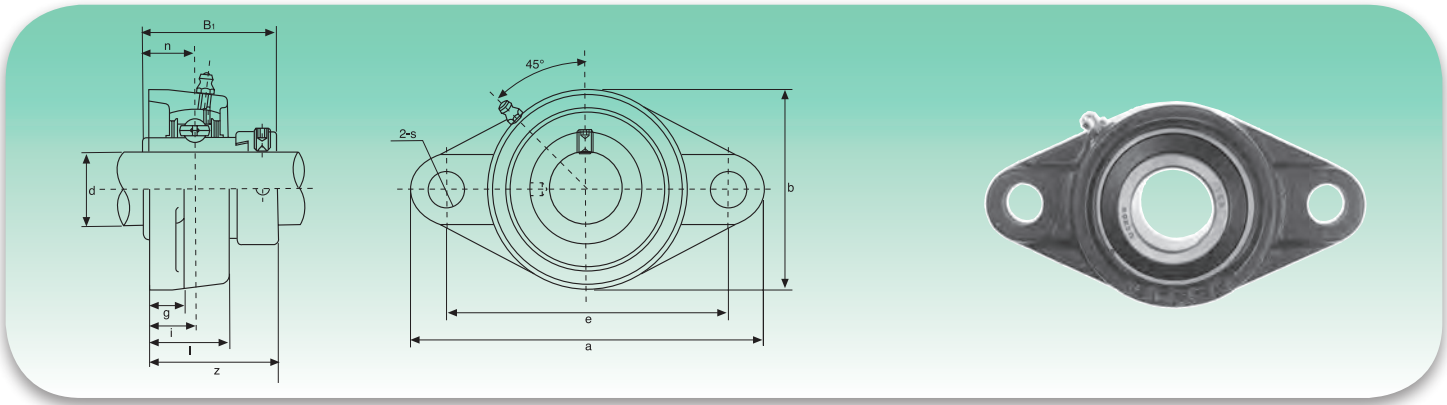

Tipo Type	Dimensiones - Dimensions											Bul. fj. Bolt Size	Coeficientes de carga (N) Load ratings (N)		Rodamiento Bearing	Soporte Housing	Peso Weight	
	d	a	e	i	g	l	s	b	z	B ₁	n		Dinámica C Dynamic C	Estática C ₀ Static C ₀				kg
	mm/inch												mm/inch					
HCFL204 HCFL204-12	20 ¾	113 47/16	90 335/64	15 19/32	11 7/16	25,5 1	12 15/32	60 23/8	41,6 141/64	43,7 1,720	17,1 0,673	M10 3/8	12160	6318	HC204 HC204-12	FL204	0,48 0,48	
HCFL205 HCFL205-13 HCFL205-14 HCFL205-15 HCFL205-16	25 13/16 7/8 15/16 1	130 51/8	99 357/64	16 5/8	13 ½	27 11/16	16 5/8	68 211/16	42,9 111/16	44,4 1,748	17,5 0,689	M14 ½	13300	7457	HC205 HC205-13 HC205-14 HC205-15 HC205-16	FL205	0,65 0,70 0,69 0,67 0,65	
HCFL206 HCFL206-17 HCFL206-18 HCFL206-19 HCFL206-20	30 11/16 11/8 13/16 1¼	148 513/16	117 439/64	18 45/64	13 ½	31 17/32	16 5/8	80 35/32	48,1 157/64	48,4 1,906	18,3 0,720	M14 ½	18525	10735	HC206 HC206-17 HC206-18 HC206-19 HC206-20	FL206	0,99 1,04 1,01 0,99 0,96	
HCFL207 HCFL207-20 HCFL207-21 HCFL207-22 HCFL207-23	35 1¼ 15/16 13/8 17/16	161 611/32	130 51/8	19 ¾	14 35/64	34 111/32	16 5/8	90 335/64	51,3 21/64	51,1 2,012	18,8 0,740	M14 ½	24415	14630	HC207 HC207-20 HC207-21 HC207-22 HC207-23	FL207	1,20 1,27 1,23 1,20 1,17	
HCFL208 HCFL208-24 HCFL208-25	40 1½ 19/16	175 67/8	144 543/64	21 53/64	14 35/64	36 113/32	16 5/8	100 315/16	55,9 213/64	56,3 2,217	21,4 0,843	M14 ½	27645	16910	HC208 HC208-24 HC208-25	FL208	1,59 1,64 1,60	
HCFL209 HCFL209-26 HCFL209-27 HCFL209-28	45 15/8 111/16 1¾	188 713/32	148 553/64	22 55/64	15 19/32	38 1½	19 ¾	108 4¼	56,9 215/64	56,3 2,217	21,4 0,843	M14 ½	32395	20235	HCF209 HC209-26 HC209-27 HC209-28	FL209	1,91 2,02 1,97 1,93	
HCFL210 HCFL210-29 HCFL210-30 HCFL210-31 HCFL210-32	50 113/16 17/8 115/16 2	197 7¾	157 63/16	22 55/64	15 19/32	40 137/64	19 ¾	115 417/32	60,1 223/64	62,7 2,469	24,6 0,969	M16 5/8	33345	22135	HCF210 HC210-29 HC210-30 HC210-31 HC210-32	FL210	2,29 2,44 2,38 2,32 2,26	
HCFL211 HCFL211-32 HCFL211-33 HCFL211-34 HCFL211-35	55 2 22/16 21/8 23/16	224 813/16	184 7¼	25 63/64	18 23/32	43 111/16	19 ¾	130 51/8	68,6 245/64	71,4 2,811	27,8 1,094	M16 5/8	41230	27930	HCF211 HC211-32 HC211-33 HC211-34 HC211-35	FL211	3,12 3,32 3,24 3,17 3,09	
HCFL212 HCFL212-36 HCFL212-37 HCFL212-38 HCFL212-39	60 2¼ 25/16 23/8 27/16	250 927/32	202 761/64	29 19/64	18 23/32	48 17/8	23 29/32	140 5½	75,8 263/64	77,8 3,063	31 1,220	M20 ¾	49780	34390	HC212 HC212-36 HC212-37 HC212-38 HC212-39	FL212	4,08 4,24 4,15 4,10 3,97	
HCFL213 HCFL213-40 HCFL213-41	65 2½ 29/16	258 105/32	210 817/64	30 13/16	22 7/8	50 131/32	23 29/32	155 63/32	81,6 37/32	85,7 3,374	34,1 1,343	M20 ¾	54340	38095	HC213 HC213-40 HC213-41	FL213	5,13 5,23 5,12	
HCFL214 HCFL214-42 HCFL214-43 HCFL214-44	70 23/8 211/16 2¾	265 107/16	216 8½	31 17/32	22 7/8	54 21/8	23 29/32	160 65/16	82,6 3¼	85,7 3,374	34,1 1,343	M20 ¾	59090	41895	HC214 HC214-42 HC214-43 HC214-44	FL214	5,61 5,85 5,74 5,62	
HCFL215 HCFL215-45 HCFL215-46 HCFL215-47 HCFL215-48	75 213/16 27/8 215/16 3	275 1013/16	225 855/64	34 111/32	22 7/8	56 27/32	23 29/32	165 6½	88,8 3½	92,1 3,626	37,3 1,426	M20 ¾	64030	45885	HC215 HC215-45 HC215-46 HC215-47 HC215-48	FL215	6,00 6,30 6,17 6,04 5,90	

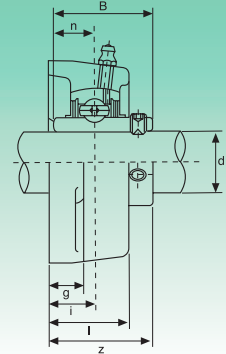
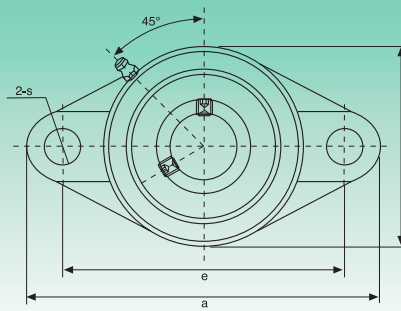

Tipo Type	Dimensiones - Dimensions											Bul. fj. Bolt Size	Coeficientes de carga (N) Load ratings (N)		Rodamiento Bearing	Soporte Housing	Peso Weight kg
	d	a	e	i	g	l	s	b	z	B	n		Dinámica C Dynamic C	Estática C ₀ Static C ₀			
	mm/inch												mm/inch				
UCFL305 UCFL305-13 UCFL305-14 UCFL305-15 UCFL305-16	25 13/16 7/8 15/16 1	150	113	16	13	29	19	80	39	38	15	M16			UC305 UC305-13 UC305-14 UC305-15 UC305-16	FL305	1,1
UCFL306 UCFL306-17 UCFL306-18 UCFL306-19	30 11/16 11/8 13/16	180	134	18	15	32	23	90	44	43	17	M20			UC306 UC306-17 UC306-18 UC306-19	FL306	1,5
UCFL307 UCFL307-20 UCFL307-21 UCFL307-22 UCFL307-23	35 1 1/4 15/16 13/8 17/16	185	141	20	16	36	23	100	49	48	19	M20			UC307 UC307-20 UC307-21 UC307-22 UC307-23	FL307	1,9
UCFL308 UCFL308-24 UCFL308-25	40 1 1/2 19/16	200	158	23	17	40	23	112	56	52	19	M20			UC308 UC308-24 UC308-25	FL308	2,5
UCFL309 UCFL309-26 UCFL309-27 UCFL309-28	45 15/8 111/16 1 3/4	230	177	25	18	44	25	125	60	57	22	M22			UC309 UC309-26 UC309-27 UC309-28	FL309	3,4
UCFL310 UCFL310-29 UCFL310-30 UCFL310-31	50 113/16 17/8 115/16	240	187	28	19	48	25	140	67	61	22	M22			UC310 UC310-29 UC310-30 UC310-31	FL310	4,4
UCFL311 UCFL311-32 UCFL311-33 UCFL311-34 UCFL311-35	55 2 21/16 21/8 23/16	250	198	30	20	52	25	150	71	66	25	M22			UC311 UC311-32 UC311-33 UC311-34 UC311-35	FL311	5,1
UCFL312 UCFL312-36 UCFL312-37 UCFL312-38 UCFL312-39	60 2 1/4 25/16 23/8 27/16	270	212	33	22	56	31	160	78	71	26	M27			UC312 UC312-36 UC312-37 UC312-38 UC312-39	FL312	6,1
UCFL313 UCFL313-40 UCFL313-41	65 2 1/2 29/16	295	240	33	25	58	31	175	78	75	30	M27			UC313 UC313-40 UC313-41	FL313	7,8
UCFL314 UCFL314-42 UCFL314-43 UCFL314-44	70 25/8 211/16 2 3/4	315	250	36	28	61	35	185	81	78	33	M30			UC314 UC314-42 UC314-43 UC314-44	FL314	9,0
UCFL315 UCFL315-45 UCFL315-46 UCFL315-47 UCFL315-48	75 213/16 27/8 215/16 3	320	260	39	30	66	35	195	89	82	32	M30			UC315 UC315-45 UC315-46 UC315-47 UC315-48	FL315	10
UCFL316 UCFL316-49 UCFL316-50 UCFL316-51	80 31/16 31/8 33/16	355	285	38	32	68	38	210	90	86	34	M33			UC316 UC316-49 UC316-50 UC316-51	FL316	13
UCFL317 UCFL317-52 UCFL317-53 UCFL317-55	85 3 1/4 35/16 37/16	370	300	44	32	74	38	220	100	96	40	M33			UC317 UC317-52 UC317-53 UC317-55	FL317	15
UCFL318 UCFL318-55 UCFL318-56	90 37/16 3 1/2	385	315	44	36	76	38	235	100	96	40	M33			UC318 UC318-55 UC318-56	FL318	18
UCFL319 UCFL319-58 UCFL319-59 UCFL319-60	95 35/8 311/16 3 3/4	405	330	59	40	94	41	250	121	103	41	M36			UC319 UC319-58 UC319-59 UC319-60	FL319	22
UCFL320 UCFL320-61 UCFL320-62 UCFL320-63 UCFL320-64	100 313/16 37/8 315/16 4	440	360	59	40	94	44	270	125	108	42	M39			UC320 UC320-61 UC320-62 UC320-63 UC320-64	FL320	27
UCFL322	110 - 18 1/2	470	390	60	42	96	44	300	131	117	46	M39			UC322	FL322	33
UCFL324	120 - 2015/32	520	430	65	48	110	47	330	140	126	51	M42			UC324	FL324	48
UCFL326	130 - 2121/32	550	460	65	50	115	47	360	146	135	54	M42			UC326	FL326	58
UCFL328	140 - 235/8	600	500	75	60	125	51	400	161	145	59	M45			UC328	FL328	81

UCFLX Serie media - Medium duty

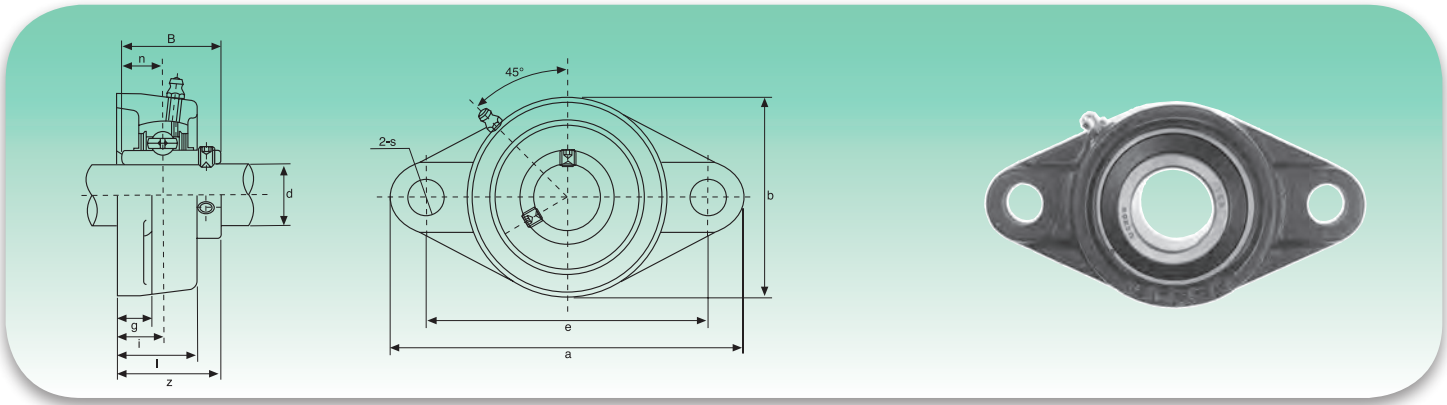

Tipo Type	Dimensiones - Dimensions											Bul. fj. Bolt Size	Coeficientes de carga (N) Load ratings (N)		Rodamiento Bearing	Soporte Housing	Peso Weight kg
	d	a	e	i	g	l	s	b	z	B	n		Dinámica C Dynamic C	Estática C ₀ Static C ₀			
	mm/inch																
UCFLX05	25	141	117	18	13	30	12	83	40,2	38,1	15,9	M10	18525	10735	UCX05	FLX05	1,0
UCFLX05-13	13/16																
UCFLX05-14	7/8																
UCFLX05-15	15/16	59/16	439/64	45/64	½	13/16	15/32	39/32	137/64	1,5000	0,626						
UCFLX05-16	1																
UCFLX06	30	156	130	19	15	34	16	95	44,4	42,9	17,5	M14	24415	14630	UCX06	FLX06	1,5
UCFLX06-17	11/16																
UCFLX06-18	11/8																
UCFLX06-19	13/16	65/32	51/8	¾	19/32	111/32	5/8	3¾	1¾	1,6890	0,689						
UCFLX06-20	1¼																
UCFLX07	35	171	144	21	16	38	16	105	51,2	49,2	19	M14	27645	16910	UCX07	FLX07	2,0
UCFLX07-21	15/16																
UCFLX07-22	13/8	623/32	543/64	53/64	5/8	1½	5/8	41/8	21/64	1,9370	0,748						
UCFLX07-23	17/16																
UCFLX08	40	179	148	22	16	40	16	111	52,2	49,2	19	M14	32395	20235	UCX08	FLX08	2,2
UCFLX08-24	1½	71/16	553/64	55/64	5/8	137/64	5/8	43/8	21/16	1,9370	0,748						
UCFLX08-25	19/16																
UCFLX09	45	189	157	23	16	40	16	116	55,6	51,6	19	M14	33345	22135	UCX09	FLX09	2,4
UCFLX09-26	15/8																
UCFLX09-27	111/16																
UCFLX09-28	1¾	77/16	63/16	29/32	5/8	137/64	5/8	49/18	23/16	2,0315	0,748						
UCFLX09-29	113/16																
UCFLX10	50	216	184	26	18	44	19	133	59,4	55,6	22,2	M16	41230	27930	UCX10	FLX10	3,4
UCFLX10-30	17/8																
UCFLX10-31	115/16	8½	7¼	11/32	23/32	123/32	¾	5¼	211/32	2,1890	0,874						
UCFLX10-32	2																

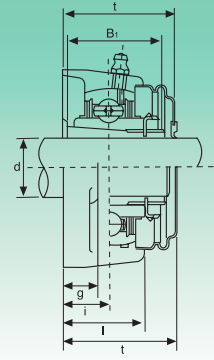
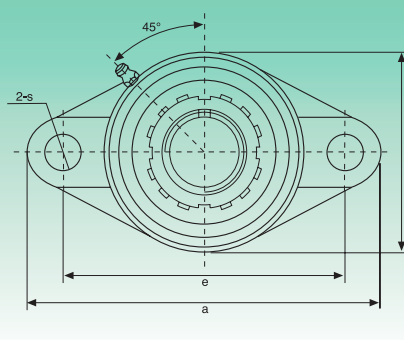
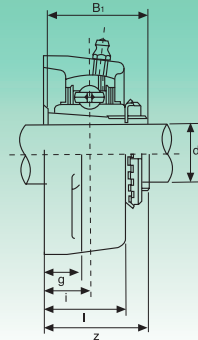
UKFL2 Serie normal - Standard duty

Tipo Type	Dimensiones - Dimensions											Bul. fij. Bolt Size	Coeficientes de carga (N) Load ratings (N)		Rodamiento Bearing	Soporte Housing	Peso Weight	
	d	a	e	i	g	l	s	b	z	t	B ₁		Dinámica C Dynamic C	Estática C ₀ Static C ₀				kg
	mm/inch												mm/inch					
UKFL205+H2305	20	130	99	16	13	27	16	68	35,5	40	35	M14	13300	7457	UK205+H2305	FL205	0,63	
UKFL205+HE2305	¾	51/8	357/64	5/8	½	11/16	5/8	211/16	125/64	19/16	1,378	½						
UKFL206+H2306	25	148	117	18	13	31	16	80	39	44,5	38	M14	18525	10735	UK206+H2306	FL206	0,90	
UKFL206+HS2306	7/8	513/16	439/64	45/64	½	17/32	5/8	35/32	117/32	1¾	1,496	½						
UKFL206+HE2306	1																	
UKFL207+H2307	30	161	130	19	14	34	16	90	42,5	48,5	43	M14	24415	14630	UK207+H2307	FL207	1,17	
UKFL207+HS2307	11/8	611/32	51/8	¾	35/64	111/32	5/8	335/64	143/64	129/32	1,693	½						
UKFL208+H2308	35	175	144	21	14	36	16	100	46,5	55,5	46	M14	27645	16910	UK208+H2308	FL208	1,54	
UKFL208+HE2308	1¼	67/8	543/64	53/64	35/64	113/32	5/8	315/16	153/64	23/16	1,811	½						
UKFL208+HS2308	13/8																	
UKFL209+H2309	40	188	148	22	15	38	19	108	48,5	56,5	50	M16	32395	20235	UK209+H2309	FL209	1,89	
UKFL209+HA2309	17/16	713/32	553/64	55/64	19/32	1½	¾	4¾	129/32	27/32	1,969	5/8						
UKFL209+HE2309	1½																	
UKFL209+HS2309	15/8																	
UKFL210+H2310	45	197	157	22	15	40	19	115	50	59,5	55	M16	33345	22135	UK210+H2310	FL210	2,27	
UKFL210+HS2310	15/8	7¾	63/16	55/64	19/32	137/64	¾	417/32	131/32	211/32	2,165	5/8						
UKFL210+HA2310	111/16																	
UKFL210+HE2310	1¾																	
UKFL211+H2311	50	224	184	25	18	43	19	130	54,5	63	59	M16	41230	27930	UK211+H2311	FL211	3,06	
UKFL211+HS2311	17/8	813/16	7¼	63/64	23/32	111/16	¾	51/8	29/64	215/32	2,323	5/8						
UKFL211+HA2311	115/16																	
UKFL211+HE2311	2																	
UKFL212+H2312	55	250	202	29	18	48	23	140	61	73,5	62	M20	49780	34390	UK212+H2312	FL212	3,79	
UKFL212+HS2312	21/8	927/32	761/64	19/64	23/32	17/8	29/32	5½	213/32	257/64	2,441	¾						
UKFL213+H2313	60	258	210	30	22	50	23	155	64	74,5	65	M20	54340	38095	UK213+H2313	FL213	4,48	
UKFL213+HA2313	23/16	105/32	817/64	13/16	7/8	131/32	29/32	63/62	233/64	215/16	2,559	¾						
UKFL213+HE2313	2¼																	
UKFL213+HS2313	23/8																	
UKFL215+H2315	65	275	225	34	22	56	23	165	71	-	73	M20	64030	45885	UK215+H2315	FL215	5,48	
UKFL215+HA2315	27/16	1013/16	855/64	111/32	7/8	27/32	29/32	6½	251/64	-	2,874	¾						
UKFL215+HE2315	2½																	
UKFL216+H2316	70	290	233	34	22	58	25	180	73,5	-	78	M22	69065	50350	UK216+H2316	FL216	7,46	
UKFL216+HA2316	211/16	1113/32	911/64	111/32	7/8	29/32	63/64	73/32	257/64	-	3,071	7/8						
UKFL216+HE2316	2¾																	
UKFL217+H2317	75	305	248	36	24	63	25	190	77	-	82	M22	79800	58805	UK217+H2317	FL217	9,03	
UKFL217+HA2317	215/16	12	949/64	127/64	15/16	215/32	63/64	715/32	31/32	-	3,228	7/8						
UKFL217+HE2317	3																	
UKFL218+H2318	80	320	265	40	24	68	25	205	81,5	-	86	M22	91295	67925	UK218+H2318	FL218	10,89	
UKFL218+HA2318	33/16	1219/32	107/16	137/64	15/16	211/16	63/64	81/16	313/64	-	3,386	7/8						

Manguitos HA; HE; HS con rosca en pulgadas
Inch dimension adapter sleeves HA; HE; HS

UKFLX Serie media - Medium duty

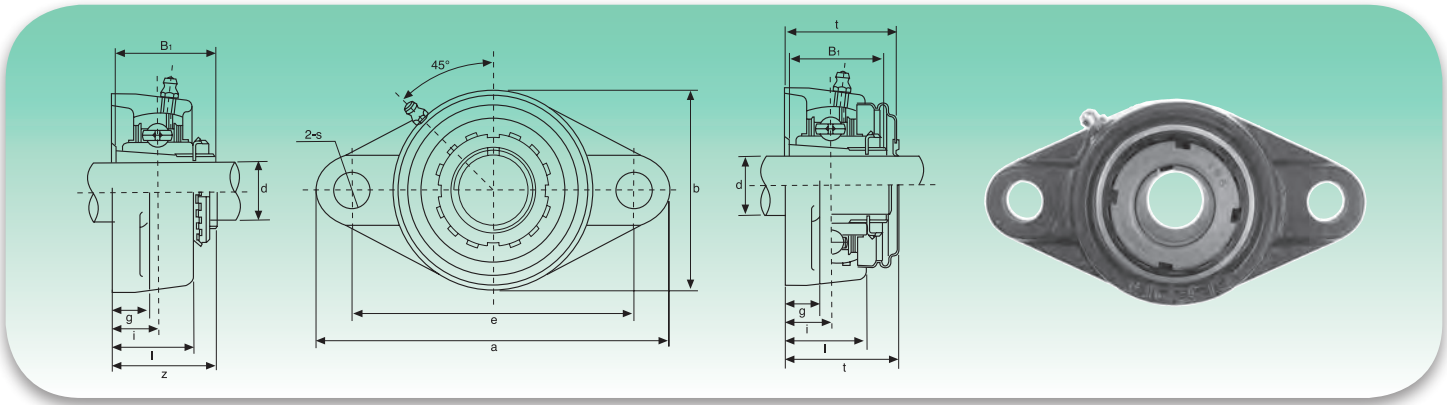

Tipo Type	Dimensiones - Dimensions										Bul. fij. Bolt Size	Coeficientes de carga (N) Load ratings (N)		Rodamiento Bearing	Soporte Housing	Peso Weight kg
	d	a	e	i	g	l	s	b	z	B ₁		Dinámica C Dynamic C	Estática C ₀ Static C ₀			
	mm/inch											mm/inch				
UKFLX05+H2305	20	141	117	18	13	30	12	83	39	35	M10	18525	10735	UKX05+H2305	FLX05	1,0
UKFLX05+HE2305	¾	59/16	439/64	45/64	½	13/16	15/32	39/32	117/32	1,378	3/8			UKX05+HE2305		
UKFLX06+H2306	25	156	130	19	15	34	16	95	41,5	38	M14	24415	14630	UKX06+H2306	FLX06	1,5
UKFLX06+HS2306	7/8	65/32	51/8	¾	19/32	111/32	5/8	3¾	141/64	1,496	½			UKX06+HS2306		
UKFLX06+HE2306	1													UKX06+HE2306		
UKFLX07+H2307	30	171	144	21	16	38	16	105	45,5	43	M14	27645	16910	UKX07+H2307	FLX07	1,8
UKFLX07+HS2307	11/8	623/32	543/64	53/64	5/8	1½	5/8	41/8	151/64	1,693	½			UKX07+HS2307		
UKFLX08+H2308	35	179	148	22	16	40	16	111	47,5	46	M14	32395	20235	UKX08+H2308	FLX08	2,1
UKFLX08+HE2308	1¾	71/16	553/64	55/64	5/8	19/16	5/8	43/8	17/8	1,811	½			UKX08+HE2308		
UKFLX08+HS2308	13/8													UKX08+HS2308		
UKFLX09+H2309	40	189	157	23	16	40	16	116	50	50	M14	33345	22135	UKX09+H2309	FLX09	2,5
UKFLX09+HA2309	17/16	77/16	63/16	29/32	5/8	137/64	5/8	49/16	131/32	1,969	½			UKX09+HA2309		
UKFLX09+HE2309	1½													UKX09+HE2309		
UKFLX09+HS2309	15/8													UKX09+HS2309		
UKFLX10+H2310	45	216	184	26	18	44	19	133	55,5	55	M16	41230	27930	UKX10+H2310	FLX10	3,7
UKFLX10+HS2310	15/8	111/16	7¼	11/32	23/32	123/32	¾	5¼	23/16	2,165	5/8			UKX10+HS2310		
UKFLX10+HA2310	8½													UKX10+HA2310		
UKFLX10+HE2310	1¾													UKX10+HE2310		

Manguitos HA; HE; HS con rosca en pulgadas
Inch dimension adapter sleeves HA; HE; HS

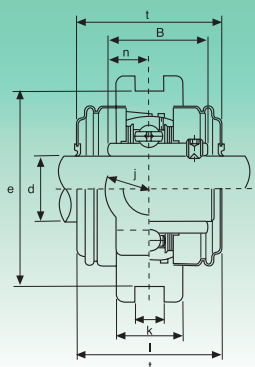
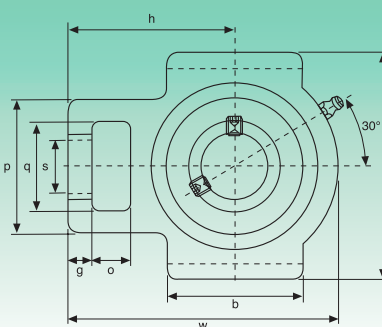
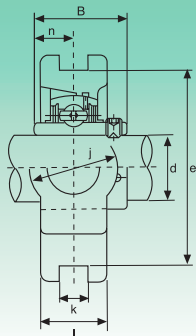
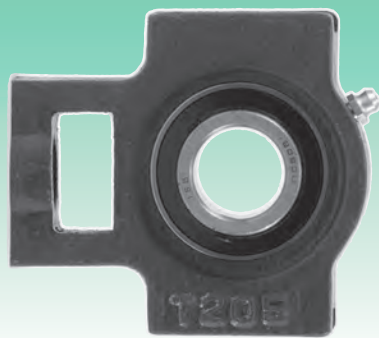

Tipo Type	Dimensiones - Dimensions																	Coeficientes de carga (N) Load ratings (N)		Rodamiento Bearing	Soporte Housing	Peso Weight					
	d	o	g	p	q	s	b	k	e	a	w	j	l	h	t	B	N	Dinámica C Dynamic C	Estática Co Static Co				kg				
UCT201	12	16	10	51	32	19	51	12	76	89	94	32	24	61	44,5	31	12,7	12160	6318	UC201 UC201-8	T204	0,80 0,79					
UCT201-8	3/4	5/8	25/64	11/64	1 1/4	3/4	21/64	15/32	263/64	3 1/2	311/16	1 1/4	15/16	213/32	1 3/4	1,2205	0,500										
UCT202	15	16	10	51	32	19	51	12	76	89	94	32	24	61	44,5	31	12,7	12160	6318	UC202 UC202-9 UC202-10	T204	0,79 0,79 0,79					
UCT202-9 UCT202-10	9/16 5/8	5/8	25/64	11/64	1 1/4	3/4	21/64	15/32	263/64	3 1/2	311/16	1 1/4	15/16	213/32	1 3/4	1,2205	0,500										
UCT203	17	16	10	51	32	19	51	12	76	89	94	32	24	61	44,5	31	12,7	12160	6318	UC203 UC203-11	T204	0,78 0,77					
UCT203-11	11/16	5/8	25/64	11/64	1 1/4	3/4	21/64	15/32	263/64	3 1/2	311/16	1 1/4	15/16	213/32	1 3/4	1,2205	0,500										
UCT204	20	16	10	51	32	19	51	12	76	89	94	32	24	61	44,5	31	12,7	12160	6318	UC204 UC204-12	T204	0,76 0,76					
UCT204-12	3/4	5/8	25/64	11/64	1 1/4	3/4	21/64	15/32	263/64	3 1/2	311/16	1 1/4	15/16	213/32	1 3/4	1,2205	0,500										
UCT205	25	16	10	51	32	19	51	12	76	89	97	32	24	62	48	34,1	14,3	13300	7457	UC205 UC205-13 UC205-14 UC205-15 UC205-16	T205	0,81 0,85 0,84 0,82 0,81					
UCT205-13 UCT205-14 UCT205-15 UCT205-16	13/16 7/8 15/16 1	5/8	25/64	11/64	1 1/4	3/4	21/64	15/32	263/64	3 1/2	313/16	1 1/4	15/16	27/16	17/8	1,3425	0,563										
UCT206	30	16	10	56	37	22	57	12	89	102	113	37	28	70	53	38,1	15,9						18525	10735	UC206 UC206-17 UC206-18 UC206-19 UC206-20	T206	1,22 1,23 1,24 1,22 1,21
UCT206-17 UCT206-18 UCT206-19 UCT206-20	11/16 11/8 13/16 1 1/4	5/8	25/64	27/32	129/64	55/64	2 1/4	15/32	3 1/2	41/64	429/64	129/64	13/32	2 3/4	23/32	1,5000	0,626										
UCT207	35	16	13	64	37	22	64	12	89	102	129	37	30	78	59,5	42,9	17,5	24415	14630	UC207 UC207-20 UC207-21 UC207-22 UC207-23	T207	1,44 1,50 1,48 1,44 1,41					
UCT207-20 UCT207-21 UCT207-22 UCT207-23	1 1/4 15/16 13/8 17/16	5/8	33/64	233/64	129/64	55/64	233/64	15/32	3 1/2	41/64	55/64	129/64	13/16	35/64	211/32	1,6890	0,689										
UCT208	40	19	16	83	49	29	83	16	102	114	144	49	35	89	69	49,2	19						27645	16910	UC208 UC208-24 UC208-25	T208	2,40 2,44 2,41
UCT208-24 UCT208-25	1 1/2 19/16	3/4	5/8	317/64	115/16	19/64	317/64	5/8	41/64	431/64	543/64	115/16	13/8	3 1/2	223/32	1,9370	0,748										
UCT209	45	19	16	83	49	29	83	16	102	117	144	49	35	87	69	49,2	19	32395	20235	UC209 UC209-26 UC209-27 UC209-28	T209	2,36 2,46 2,42 2,38					
UCT209-26 UCT209-27 UCT209-28	15/8 11/16 1 3/4	3/4	5/8	317/64	115/16	19/64	317/64	5/8	41/64	439/64	543/64	115/16	13/8	327/64	223/32	1,9370	0,748										
UCT210	50	19	16	83	49	29	86	16	102	117	149	49	35	90	74,5	51,6	19						33345	22135	UC210 UC210-29 UC210-30 UC210-31 UC210-32	T210	2,43 2,55 2,50 2,45 2,41
UCT210-29 UCT210-30 UCT210-31 UCT210-32	113/16 17/8 115/16 2	3/4	5/8	317/64	115/16	19/64	317/64	5/8	41/64	439/64	555/64	115/16	13/8	335/64	215/16	2,0315	0,748										
UCT211	55	25	19	102	64	35	95	22	130	146	171	64	41	106	76	55,6	22,2	41230	27930	UC211 UC211-32 UC211-33 UC211-34 UC211-35	T211	4,11 4,26 4,20 4,15 4,09					
UCT211-32 UCT211-33 UCT211-34 UCT211-35	2 21/16 21/8 23/16	63/64	3/4	41/64	21/32	13/8	3 3/4	55/64	51/8	5 3/4	647/64	233/64	15/8	411/64	3	2,1890	0,874										
UCT212	60	32	19	102	64	35	102	22	130	146	194	64	46	119	89	65,1	25,4						49780	34390	UC212 UC212-36 UC212-37 UC212-38 UC212-39	T212	4,97 5,10 5,02 4,95 4,88
UCT212-36 UCT212-37 UCT212-38 UCT212-39	2 1/4 25/16 23/8 27/16	117/64	3/4	41/64	21/32	13/8	41/64	55/64	51/8	5 3/4	741/64	233/64	113/16	411/16	3 1/2	2,5630	1,000										
UCT213	65	32	21	111	70	41	121	26	151	167	224	70	51	137	89	65,1	25,4	54340	38095	UC213 UC213-40 UC213-41	T213	6,65 6,74 6,65					
UCT213-40 UCT213-41	2 1/2 29/16	117/64	53/64	43/8	2 3/4	139/64	449/64	11/32	515/16	637/64	813/16	2 3/4	2	525/64	3 1/2	2,5630	1,000										
UCT214	70	32	21	111	70	41	121	26	151	167	224	70	46	137	-	74,6	30,2						59090	41895	UC214 UC214-42 UC214-43 UC214-44	T214	7,05 7,26 7,16 7,06
UCT214-42 UCT214-43 UCT214-44	25/8 21/16	117/64	53/64	43/8	2 3/4	139/64	449/64	11/32	515/16	637/64	813/16	2 3/4	113/16	525/64	-	2,9370	1,189										
UCT215	75	32	21	111	70	41	121	26	151	167	232	70	48	140	-	77,8	33,3	64030	45885	UC215 UC215-45 UC215-46 UC215-47 UC215-48	T215	7,41 7,66 7,55 7,44 7,32					
UCT215-45 UCT215-46 UCT215-47 UCT215-48	213/16 27/8 215/16 3	117/64	53/64	43/8	2 3/4	139/64	449/64	11/32	515/16	637/64	99/64	2 3/4	157/64	533/64	-	3,0630	1,311										
UCT216	80	32	21	111	70	41	121	26	165	184	235	70	51	140	-	82,6	33,3						69065	50350	UC216 UC216-49 UC216-50 UC216-51	T216	8,30 8,48 8,35 8,22
UCT216-49 UCT216-50 UCT216-51	31/16 31/8 33/16	117/64	53/64	43/8	2 3/4	139/64	449/64	11/32	6 1/2	7 1/4	9 1/4	2 3/4	2	533/64	-	3,2520	1,311										
UCT217	85	38	29	124	73	48	157	30	173	189	260	73	54	162	-	85,7	34,1	79800	58805	UC217 UC217-52 UC217-53 UC217-55	T217	11,00 11,22 11,09 10,80					
UCT217-52 UCT217-53 UCT217-55	3 3/4 35/16 37/16	1 1/2	19/64	47/8	27/8	157/64	63/16	13/16	613/16	751/64	1015/64	27/8	21/8	63/8	-	3,3740	1,343										
UCT218	90	41	31	132	81	48	151	30	189	216	280	80	55	173	-	96	39,7						91295	67925	UC218 UC218-56	T218	12,75 10,62
UCT218-56	35/64	15/8	1,2205	513/64	36/32	157/64	561/64	13/16	751/64	8 1/2	1113/32	35/32	2,165	613/16	-	3,7795	118/32										

Disponibile en acero inox. Soporte: AISI 304 - Rodamiento: AISI 440C - Available stainless steel Housing: AISI 304 - Bearing: AISI 440C
 Disponible bajo demanda con rodamiento SA (SAT...) - Available under request with SA bearing (SAT...)

HCT2 Serie normal - Normal duty

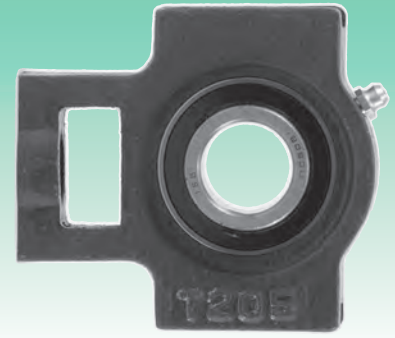
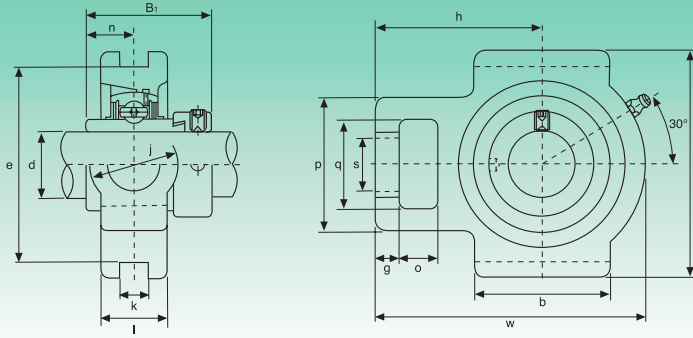

Tipo Type	Dimensiones - Dimensions																Coeficientes de carga (N) Load ratings (N)		Rodamiento Bearing	Soporte Housing	Peso Weight
	d	o	g	p	q	s	b	k	e	a	w	j	i	h	B ₁	n	Dinámica C Dynamic C	Estática C ₀ Static C ₀			
	mm/inch																				
HCT204	20	16	10	51	32	19	51	12	76	89	94	32	24	61	43,7	17,1	12160	6318	HC204	T204	0,83
HCT204-12	¾	5/8	25/64	11/16	1¼	¾	21/64	15/32	263/64	3½	311/16	1¼	15/16	213/32	1,720	0,673			HC204-12		0,83
HCT205	25	16	10	51	32	19	51	12	76	89	97	32	24	62	44,4	17,5	13300	7457	HC205	T205	0,88
HCT205-13	13/16																		HC205-13		0,93
HCT205-14	7/8																		HC205-14		0,92
HCT205-15	15/16	5/8	25/64	11/16	1¼	¾	21/64	15/32	263/64	3½	313/16	1¼	15/16	27/16	1,748	0,689			HC205-15		0,90
HCT205-16	1																		HC205-16		0,88
HCT206	30	16	10	56	37	22	57	12	89	102	113	37	28	70	48,4	18,3	18525	10735	HC206	T206	1,35
HCT206-17	11/16																		HC206-17		1,40
HCT206-18	11/8																		HC206-18		1,37
HCT206-19	13/16	5/8	25/64	27/32	129/64	55/64	2¼	15/32	3½	41/64	429/64	129/64	13/32	2¾	1,906	0,720			HC206-19		1,35
HCT206-20	1¼																		HC206-20		1,32
HCT207	35	16	13	64	37	22	64	12	89	102	129	37	30	78	51,1	18,8	24415	14630	HC207	T207	1,56
HCT207-20	1¼																		HC207-20		1,63
HCT207-21	15/16																		HC207-21		1,59
HCT207-22	13/8	5/8	33/64	233/64	129/64	55/64	233/64	15/32	3½	41/64	55/64	129/64	13/16	35/64	2,012	0,740			HC207-22		1,56
HCT207-23	17/16																		HC207-23		1,53
HCT208	40	19	16	83	49	29	83	16	102	114	144	49	35	89	56,3	21,4	27645	16910	HC208	T208	2,55
HCT208-24	1½																		HC208-24		2,60
HCT208-25	19/16	¾	5/8	317/64	115/16	19/64	317/64	5/8	41/64	431/64	543/64	115/16	13/8	3½	2,217	0,843			HC208-25		2,56
HCT209	45	19	16	83	49	29	83	16	102	117	144	49	35	87	56,3	21,4	32395	20235	HCF209	T209	2,53
HCT209-26	15/8																		HC209-26		2,64
HCT209-27	111/16	¾	5/8	317/64	115/16	19/64	317/64	5/8	41/64	439/64	543/64	115/16	13/8	327/64	2,217	0,843			HC209-27		2,59
HCT209-28	1¾																		HC209-28		2,55
HCT210	50	19	16	83	49	29	86	16	102	117	149	49	35	90	6,7	24,6	33345	22135	HCF210	T210	2,62
HCT210-29	113/16																		HC210-29		2,77
HCT210-30	17/8																		HC210-30		2,71
HCT210-31	115/16	¾	5/8	317/64	115/16	19/64	325/64	5/8	41/64	439/64	555/64	115/16	13/8	335/64	2,469	0,969			HC210-31		2,65
HCT210-32	2																		HC210-32		2,59
HCT211	55	25	19	102	64	35	95	22	130	146	171	64	41	106	71,4	27,8	41230	27930	HCF211	T211	4,32
HCT211-32	2																		HC211-32		4,52
HCT211-33	22/16																		HC211-33		4,44
HCT211-34	21/8	63/64	¾	41/64	21/32	13/8	3¾	55/64	51/8	5¾	647/64	233/64	15/8	411/64	2,811	1,094			HC211-34		4,37
HCT211-35	23/16																		HC211-35		4,29
HCT212	60	32	19	102	64	35	102	22	130	146	194	64	46	119	77,8	31	49780	34390	HC212	T212	5,31
HCT212-36	2¼																		HC212-36		5,47
HCT212-37	25/16																		HC212-37		5,38
HCT212-38	23/8	117/64	¾	41/64	21/32	13/8	41/64	55/64	51/8	5¾	741/64	233/64	113/16	411/16	3,063	1,220			HC212-38		5,33
HCT212-39	27/16																		HC212-39		5,20
HCT213	65	32	21	111	70	41	121	26	151	167	224	70	51	137	85,7	34,1	54340	38095	HC213	T213	7,21
HCT213-40	2½																		HC213-40		7,31
HCT213-41	29/16	117/64	53/64	43/8	2¾	139/64	449/64	11/32	515/16	6637/64	8183/16	2¾	2	525/64	3,374	1,343			HC213-41		7,20
HCT214	70	32	21	111	70	41	121	26	151	167	224	70	46	137	85,7	34,1	59090	41895	HC214	T214	7,55
HCT214-42	23/8																		HC214-42		7,79
HCT214-43	211/16	117/64	53/64	43/8	2¾	139/64	449/64	11/32	515/16	6637/64	8183/16	2¾	113/16	525/64	3,374	1,343			HC214-43		7,68
HCT214-44	2¾																		HC214-44		7,56
HCT215	75	32	21	111	70	41	121	26	151	167	232	70	48	140	92,1	37,3	64030	45885	HC215	T215	8,04
HCT215-45	213/16																		HC215-45		8,34
HCT215-46	27/8																		HC215-46		8,21
HCT215-47	215/16	117/64	53/64	43/8	2¾	139/64	449/64	11/32	515/16	6637/64	99/64	2¾	157/64	533/64	3,626	1,426			HC215-47		8,08
HCT215-48	3																		HC215-48		7,94

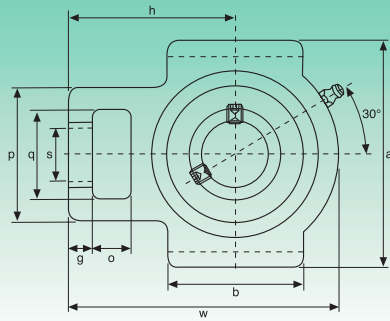
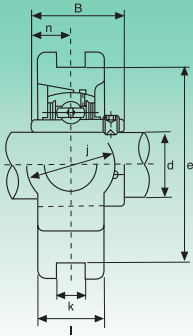

Tipo Type	Dimensiones - Dimensions															Coeficientes de carga (N) Load ratings (N)		Rodamiento Bearing	Soporte Housing	Peso Weight kg		
	d	o	g	p	q	s	b	k	e	a	w	j	l	h	B	n	Dinámica C Dynamic C				Estática C _o Static C _o	
	mm/inch																					
UCTX05	25	16	12	56	37	22	57	12	89	102	113	28	37	70	38,1	15,9	18525	10735	UCTX05	TX05	1,4	
UCTX05-13	13/16																					UCTX05-13
UCTX05-14	7/8	5/8	15/32	27/32	129/64	55/64	2 1/4	0,472	3 1/2	41/64	429/64	13/32	129/64	2 3/4	1,5000	0,626						UCTX05-14
UCTX05-15	15/16																					UCTX05-15
UCTX05-16	1																					UCTX05-16
UCTX06	30	16	15	64	37	22	64	12	89	102	129	30	37	78	42,9	17,5	24415	14630	UCTX06	TX06	1,8	
UCTX06-17	11/16																					UCTX06-17
UCTX06-18	11/8	5/8	19/32	233/64	129/64	55/64	233/64	0,472	3 1/2	41/64	55/64	13/16	129/64	35/64	1,6890	0,689						UCTX06-18
UCTX06-19	13/16																					UCTX06-19
UCTX06-20	1 1/4																					UCTX06-20
UCTX07	35	19	17	83	49	29	83	16	102	114	144	36	49	88	49,2	19	27645	16910	UCTX07	TX07	2,6	
UCTX07-21	15/16																					UCTX07-21
UCTX07-22	13/8	3/4	21/32	317/64	115/16	19/64	317/64	0,630	41/64	431/64	543/64	113/32	115/16	315/32	1,9370	0,748						UCTX07-22
UCTX07-23	17/16																					UCTX07-23
UCTX08	40	19	17	83	49	29	83	16	102	117	144	36	49	87	49,2	19	32395	20235	UCTX08	TX08	2,6	
UCTX08-24	1 1/2	3/4	21/32	317/64	115/16	19/64	317/64	0,630	41/64	439/64	543/64	113/32	115/16	327/64	1,9370	0,748						UCTX08-24
UCTX08-25	19/16																					UCTX08-25
UCTX09	45	19	18	83	49	29	86	16	102	117	151	38	49	92	51,6	19	33345	22135	UCTX09	TX09	2,8	
UCTX09-26	15/8																					UCTX09-26
UCTX09-27	111/16	3/4	23/32	317/64	115/16	19/64	325/64	0,630	41/64	439/64	515/16	1 1/2	115/16	35/8	2,0315	0,748						UCTX09-27
UCTX09-28	1 3/4																					UCTX09-28
UCTX09-29	113/16																					UCTX09-29
UCTX10	50	25	21	102	64	35	95	22	130	146	171	42	64	106	55,6	22,2	41230	27930	UCTX10	TX10	4,3	
UCTX10-30	17/8																					UCTX10-30
UCTX10-31	115/16	63/64	13/16	41/64	21/32	13/8	3 3/4	0,866	51/8	5 3/4	647/64	121/32	233/64	411/64	2,1890	0,874						UCTX10-31
UCTX10-32	2																	UCTX10-32				
UCTX11	55	32	21	102	64	35	102	22	130	146	194	44	64	119	65,1	25,4	49780	34390	UCTX11	TX11	5,2	
UCTX11-33	21/16																					UCTX11-33
UCTX11-34	21/8																					UCTX11-34
UCTX11-35	23/16	117/64	13/16	41/64	21/32	13/8	41/64	0,866	51/8	5 3/4	741/64	123/32	233/64	411/16	2,5630	1,000						UCTX11-35
UCTX11-36	2 1/4																					UCTX11-36
UCTX11-37	25/16																	UCTX11-37				
UCTX12	60	32	23	111	70	41	121	26	151	167	224	48	70	137	65,1	25,4	54340	38095	UCTX12	TX12	7,6	
UCTX12-38	23/8																					UCTX12-38
UCTX12-39	27/16	117/64	29/32	43/8	2 3/4	139/64	449/64	1,024	515/16	637/64	813/16	157/64	2 3/4	525/64	2,5630	1,000						UCTX12-39
UCTX13	65	32	23	111	70	41	121	26	151	167	224	48	70	137	74,6	30,2	59090	41895	UCTX13	TX13	7,6	
UCTX13-40	2 1/2																					UCTX13-40
UCTX13-41	29/16	117/64	29/32	43/8	2 3/4	139/64	449/64	1,024	515/16	637/64	813/16	157/64	2 3/4	525/64	2,9370	1,189						UCTX13-41
UCTX14	70	32	23	111	70	41	121	26	151	167	232	48	70	140	77,8	33,3	64030	45885	UCTX14	TX14	7,7	
UCTX14-42	25/8																					UCTX14-42
UCTX14-43	211/16	117/64	29/32	43/8	2 3/4	139/64	449/64	1,024	515/16	637/64	99/64	157/64	2 3/4	533/64	3,0630	1,311						UCTX14-43
UCTX14-44	2 3/4																	UCTX14-44				
UCTX15	75	32	23	111	70	41	121	28	165	184	235	48	70	140	82,6	33,3	69065	50350	UCTX15	TX15	7,55	
UCTX15-45	213/16																					UCTX15-45
UCTX15-46	27/8																					UCTX15-46
UCTX15-47	215/16	117/64	29/32	43/8	2 3/4	139/64	449/64	1,102	6 1/2	7 1/4	9 1/4	157/64	2 3/4	533/64	3,2520	1,311						UCTX15-47
UCTX15-48	3																					UCTX15-48
UCTX16	80	38	30	124	73	48	157	28	173	198	260	54	73	162	85,7	34,1	79800	58805	UCTX16	TX16	11	
UCTX16-49	31/16																					UCTX16-49
UCTX16-50	31/8	1 1/2	13/16	47/8	27/8	157/64	63/16	1,102	613/16	751/64	1015/64	21/8	27/8	63/8	3,3740	1,343						UCTX16-50
UCTX16-51	33/16																					UCTX16-51
UCTX16-52	3 1/4																					UCTX16-52
UCTX17	85	38	30	124	73	48	157	28	173	198	260	54	73	162	96	39,7	91295	67925	UCTX17	TX17	12	
UCTX17-53	35/16	1 1/2	13/16	47/8	27/8	157/64	63/16	1,102	613/16	751/64	1015/64	21/8	27/8	63/8	3,7795	1,5630						UCTX17-53
UCTX17-54	37/16																					UCTX17-54

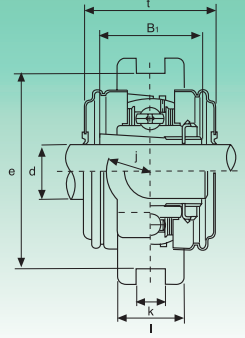
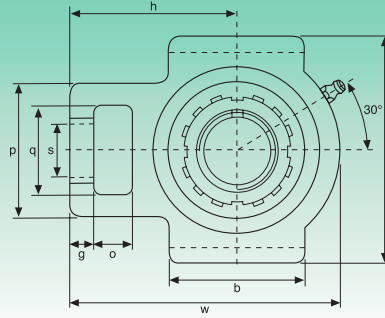
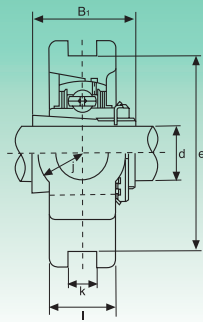
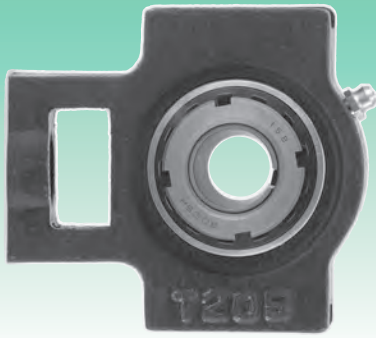
UKT2 Serie normal - Standard duty

Tipo Type	Dimensiones - Dimensions																Coeficientes de carga (N) Load ratings (N)		Rodamiento Bearing	Soporte Housing	Peso Weight
	d	o	g	p	q	s	b	k	e	a	w	j	l	h	t	B ₁	Dinámica C Dynamic C	Estática C ₀ Static C ₀			
	mm/inch																				
UKT205+H2305	20	16	10	51	32	19	51	12	76	89	97	32	24	62	48	35	13300	7457	UK205+H2305	T205	0,86
UKT205+HE2305	¾	5/8	25/64	11/64	1¼	¾	21/64	15/32	263/64	3½	313/16	1¼	15/16	27/16	17/8	1,378			UK205+HE2305		
UKT206+H2306	25	16	10	56	37	22	57	12	89	102	113	37	28	70	53	38	18525	10735	UK206+H2306	T206	1,26
UKT206+HS2306	7/8	5/8	25/64	27/32	115/32	55/64	2¼	15/32	3½	41/64	429/64	129/64	13/32	2¾	23/32	1,496			UK206+HS2306		
UKT206+HE2306	1																				
UKT207+H2307	30	16	13	64	37	22	64	12	89	102	129	37	30	78	59,5	43	24415	14630	UK207+H2307	T207	2,50
UKT207+HS2307	11/8	5/8	33/64	233/64	115/32	55/64	233/64	15/32	3½	41/64	55/64	129/64	13/16	35/64	211/32	1,693			UK207+HS2307		
UKT208+H2308	35	19	16	83	49	29	83	16	102	114	144	49	35	89	69	46	27645	16910	UK208+H2308	T208	2,50
UKT208+HE2308	1¼	¾	5/8	317/64	115/16	19/64	317/64	5/8	41/64	431/64	543/64	115/16	13/8	3½	223/32	1,811			UK208+HE2308		
UKT208+HS2308	13/8																				
UKT209+H2309	40	19	16	83	49	29	83	16	102	117	144	49	35	87	69	50	32395	20235	UK209+H2309	T209	2,51
UKT209+HA2309	17/16	¾	5/8	317/64	115/16	19/64	317/64	5/8	41/64	439/64	543/64	115/16	13/8	327/64	223/32	1,969			UK209+HA2309		
UKT209+HE2309	1½																				
UKT209+HS2309	15/8																				
UKT210+H2310	45	19	16	83	49	29	86	16	102	117	149	49	35	90	74,5	55	33345	22135	UK210+H2310	T210	2,60
UKT210+HS2310	15/8	¾	5/8	317/64	115/16	19/64	325/64	5/8	41/64	439/64	555/64	115/16	13/8	335/64	215/16	2,165			UK210+HS2310		
UKT210+HA2310	111/16																				
UKT210+HE2310	1¾																				
UKT211+H2311	50	25	19	102	64	35	95	22	130	146	171	64	41	106	76	59	41230	27930	UK211+H2311	T211	4,26
UKT211+HS2311	17/8	115/16	63/64	¾	41/64	21/32	13/8	3¾	55/64	51/8	5¾	647/64	233/64	15/8	411/64	3			2,323		
UKT211+HA2311	2																				
UKT211+HE2311	2																				
UKT212+H2312	55	32	19	102	64	35	102	22	130	146	194	64	46	119	89	62	49780	34390	UK212+H2312	T212	5,02
UKT212+HS2312	21/8	117/64	¾	41/64	21/32	13/8	41/64	55/64	51/8	5¾	741/64	233/64	113/16	411/16	3½	2,441			UK212+HS2312		
UKT213+H2313	60	32	21	111	70	41	121	26	151	167	224	70	51	137	89	65	54340	38095	UK213+H2313	T213	6,56
UKT213+HA2313	23/16	117/64	53/64	43/8	2¾	139/64	449/64	11/32	515/16	637/64	813/16	2¾	2	525/64	3½	2,559			UK213+HA2313		
UKT213+HE2313	2¼																				
UKT213+HS2313	23/8																				
UKT215+H2315	65	32	21	111	70	41	121	26	151	167	232	70	48	140	-	73	64030	45885	UK215+H2315	T215	7,52
UKT215+HA2315	27/16	117/64	53/64	43/8	2¾	139/64	449/64	11/32	515/16	637/64	99/64	2¾	157/64	533/64	-	2,874			UK215+HA2315		
UKT215+HE2315	2½																				
UKT216+H2316	70	32	21	111	70	41	121	26	165	184	235	70	51	140	-	78	69065	50350	UK216+H2316	T216	8,56
UKT216+HA2316	211/16	117/64	53/64	43/8	2¾	139/64	449/64	11/32	6½	7¼	9¼	2¾	2	533/64	-	3,071			UK216+HA2316		
UKT216+HE2316	2¾																				
UKT217+H2317	75	38	29	124	73	48	157	30	173	198	260	73	54	162	-	82	79800	58805	UK217+H2317	T217	11,38
UKT217+HA2317	215/16	1½	19/64	47/8	27/8	157/64	63/16	13/16	613/16	751/64	1015/64	27/8	21/8	63/8	-	3,228			UK217+HA2317		
UKT217+HE2317	3																				

Manguitos HA; HE; HS con rosca en pulgadas
Inch dimension adapter sleeves HA; HE; HS

UKTX Serie media - Medium duty

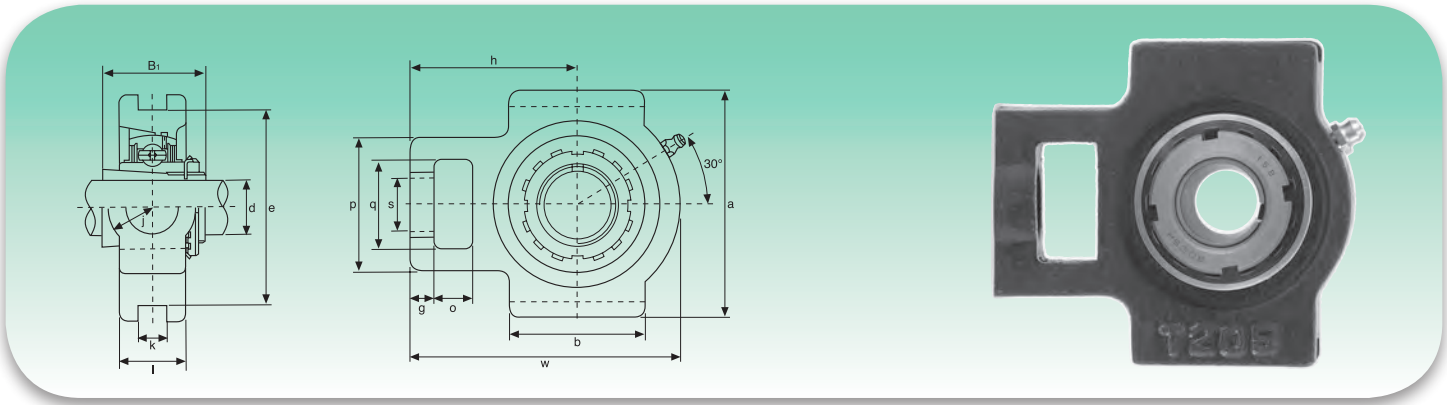

Tipo Type	Dimensiones - Dimensions															Coeficientes de carga (N) Load ratings (N)		Rodamiento Bearing	Soporte Housing	Peso Weight
	d	o	g	p	q	s	b	k	e	a	w	l	j	h	B1	Dinámica C Dynamic C	Estática Co Static Co			
	mm/inch																			
UKTX05+H2305	20	16	12	56	37	22	57	12	89	102	113	28	37	70	35	18525	10735	UKX05+H2305	TX05	1,3
UCTX05+HE2305	¾	5/8	15/32	27/32	129/64	55/64	2¼	0,472	3½	41/64	429/64	13/32	129/64	2¾	1,378			UKX05+HE2305		
UKTX06+H2306	25	16	15	64	37	22	64	12	89	102	129	30	37	78	38	24415	14630	UKX06+H2306	TX06	1,7
UKTX06+HS2306	7/8	5/8	19/32	233/64	129/64	55/64	233/64	0,472	3½	41/64	55/64	13/16	129/64	35/64	1,496			UKX06+HS2306		
UKTX06+HE2306	1																			
UKTX07+H2307	30	19	17	83	49	29	83	16	102	114	144	36	49	88	43	27645	16910	UKX07+H2307	TX07	2,6
UKTX07+HS2307	11/8	¾	21/32	317/64	115/16	19/64	317/64	0,630	41/64	431/64	543/64	113/32	115/16	315/32	1,811			UKX07+HS2307		
UKTX08+H2308	35	19	17	83	49	29	83	16	102	117	144	36	49	87	46	32395	20235	UKX08+H2308	TX08	2,6
UKTX08+HE2308	1¼	¾	21/32	317/64	115/16	19/64	317/64	0,630	41/64	439/64	543/64	113/32	115/16	327/64	1,811			UKX08+HE2308		
UKTX08+HS2308	13/8																			
UKTX09+H2309	40	19	18	83	49	29	86	16	102	117	151	38	49	92	50	33345	22135	UKX09+H2309	TX09	2,9
UKTX09+HA2309	17/16	¾	23/32	317/64	115/16	19/64	325/64	0,630	41/64	439/64	515/16	1½	115/16	35/8	1,969			UKX09+HA2309		
UKTX09+HE2309	1½																			
UKTX09+HS2309	15/8																			
UKTX10+H2310	45	25	21	102	64	35	95	22	130	146	171	42	64	106	55	41230	27930	UKX10+H2310	TX10	4,4
UKTX10+HS2310	15/8	111/16	63/64	13/16	41/64	21/32	13/8	¾	0,866	51/8	5¾	647/64	121/32	233/64	411/64			2,165		
UKTX10+HA2310	111/16																			
UKTX10+HE2310	1¾																			
UKTX11+H2311	50	32	21	102	64	35	102	22	130	146	194	44	64	119	59	49780	34390	UKX11+H2311	TX11	5,1
UKTX11+HS2311	17/8	115/16	117/64	13/16	41/64	21/32	13/8	41/64	0,866	51/8	5¾	741/64	123/32	233/64	441/16			2,323		
UKTX11+HA2311	115/16																			
UKTX11+HE2311	2																			
UKTX12+H2312	55	32	23	111	70	41	121	26	151	167	224	48	70	137	62	54340	38095	UKX12+H2312	TX12	7,3
UKTX12+HS2312	21/8	117/64	29/32	43/8	2¾	139/64	449/64	1,024	515/16	637/64	813/16	157/64	2¾	525/64	2,441			UKX12+HS2312		
UKTX13+H2313	60	32	23	111	70	41	121	26	151	167	224	48	70	137	65	59090	41895	UKX13+H2313	TX13	7,2
UKTX13+HA2313	23/16	117/64	29/32	43/8	2¾	139/64	449/64	1,024	515/16	637/64	813/16	157/64	2¾	525/64	2,559			UKX13+HA2313		
UKTX13+HE2313	2¼																			
UKTX13+HS2313	23/8																			
UKTX15+H2315	65	32	23	111	70	41	121	26	151	167	232	48	70	140	73	69065	50350	UKX15+H2315	TX15	8,4
UKTX15+HA2315	27/16	117/64	29/32	43/8	2¾	139/64	449/64	1,024	515/16	637/64	99/64	157/64	2¾	533/64	3,559			UKX15+HA2315		
UKTX15+HS2315	23/8																			
UKTX16+H2316	70	38	30	124	73	48	157	28	173	198	260	54	73	162	78	79800	58805	UKX16+H2316	TX16	11,8
UKTX16+HA2316	211/16	1½	13/16	47/8	27/8	157/64	63/16	1,102	613/16	751/64	1015/64	21/8	27/8	63/8	3,071			UKX16+HA2316		
UKTX16+HE2316	2¾																			
UKTX17+H2317	75	38	30	124	73	48	157	28	173	198	260	54	73	162	82	91295	67925	UKX17+H2317	TX17	11,4
UKTX17+HA2317	215/16	1½	13/16	47/8	27/8	157/64	63/16	1,102	613/16	751/64	1015/64	21/8	27/8	63/8	3,228			UKX17+HA2317		
UKTX17+HS2317	3																			

Manguitos HA; HE; HS con rosca en pulgadas
Inch dimension adapter sleeves HA; HE; HS

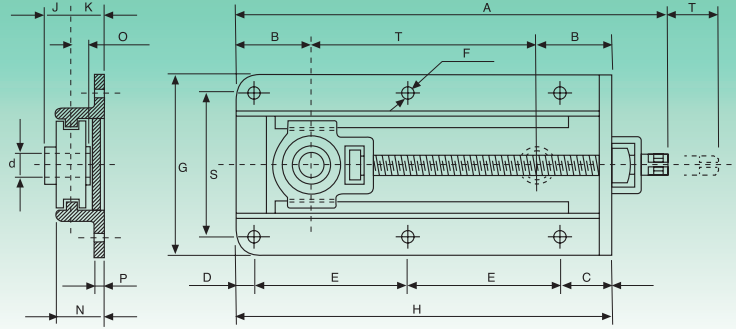
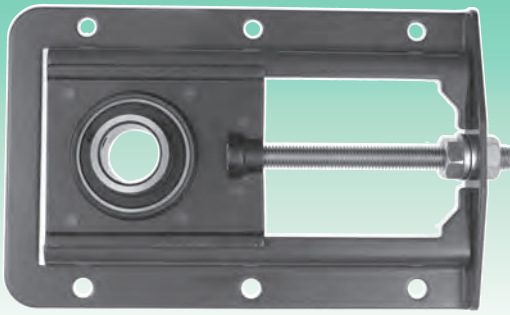
UCT2 Serie normal - Standard duty

Tipo Type	Dimensiones - Dimensions																Peso Weight kg
	d	A	B	C	D	E	F	G	H	J	K	N	O	P	S	T	
	mm/inch																
UCT204	20	380	80	60	20	120	11	194	320	18,3	28	45	12,7	5	154	160	4,4
UCT205	25	380	80	60	20	120	11	194	320	19,7	28	45	14,3	5	154	160	4,4
UCT206	30	480	95	64	20	158	11	206	400	22,2	32	45	15,9	5	166	210	6,2
UCT207	35	480	95	64	20	158	11	206	400	25,4	32	45	17,5	5	166	210	6,5
UCT208	40	600	105	58	22	220	13	234	520	30,2	32	50	19	5	190	310	10,9
UCT209	45	600	105	58	22	220	13	234	520	30,2	32	50	19	5	190	310	10,8
UCT210	50	600	105	58	22	220	13	234	520	32,6	32	50	19	5	190	310	11
UCT211	55	680	125	55	25	250	15	284	580	33,4	45	70	22,2	6	240	330	20,4
UCT212	60	680	125	55	25	250	15	284	580	39,7	45	70	25,4	6	240	330	21,3
UCT213	65	790	155	66	22	306	18	303	700	39,7	51	75	25,4	6	258	390	28,3
UCT214	70	790	155	66	22	306	18	303	700	44,4	51	75	30,2	6	258	390	28,1
UCT215	75	790	155	66	22	306	18	303	700	44,5	51	75	33,3	6	258	390	28,7
UCT216	80	890	165	75	25	230*	18	336	790	49,3	62	90	33,3	10	286	460	38,2
UCT217	85	920	180	75	25	240*	18	361	820	51,6	62	100	34,1	10	311	460	44

* Placas con cuatro agujeros de fijación
Stretch skid with four fixing hole

PLACA CON TENSOR PARA UCT - STRETCH SKID FOR UCT
UCTX2 Serie media - Medium duty

Tipo Type	Dimensiones - Dimensions																Peso Weight kg
	d	A	B	C	D	E	F	G	H	J	K	N	O	P	S	T	
	mm/inch																
UCTX-05	25	480	95	64	20	158	11	206	400	22,2	32	45	15,9	5	166	210	6,8
UCTX-06	30	480	95	64	20	158	11	206	400	25,4	32	45	17,5	5	166	210	7,0
UCTX-07	35	600	105	58	22	220	13	234	520	30,2	32	50	19,0	5	190	310	11,1
UCTX-08	40	600	105	58	22	220	13	234	520	30,2	32	50	19,0	5	190	310	11,1
UCTX-09	45	600	105	58	22	220	13	234	520	32,6	32	50	19,0	5	190	310	11,3
UCTX-10	50	680	125	55	25	250	15	284	580	33,4	45	70	22,2	6	240	330	20,1
UCTX-11	55	680	125	55	25	250	15	284	580	39,7	45	70	25,4	6	240	330	20,9
UCTX-12	60	790	155	66	22	306	18	303	700	39,7	51	75	25,4	6	258	390	28,1
UCTX-13	65	790	155	66	22	306	18	303	700	44,4	51	75	30,2	6	258	390	28,3
UCTX-14	70	790	155	66	22	306	18	303	700	44,5	51	75	33,3	6	258	390	28,6
UCTX-15	75	890	165	75	25	230*	18	336	790	49,3	62	90	33,3	10	286	460	38,1
UCTX-16	80	920	180	75	25	240*	18	365	820	51,6	62	100	34,1	10	315	460	49,5
UCTX-17	85	920	180	75	25	240*	18	365	820	56,3	62	100	39,7	10	315	460	49,4

* Placas con cuatro agujeros de fijación
Stretch skid with four fixing hole

UCC2 Serie normal - Standard duty

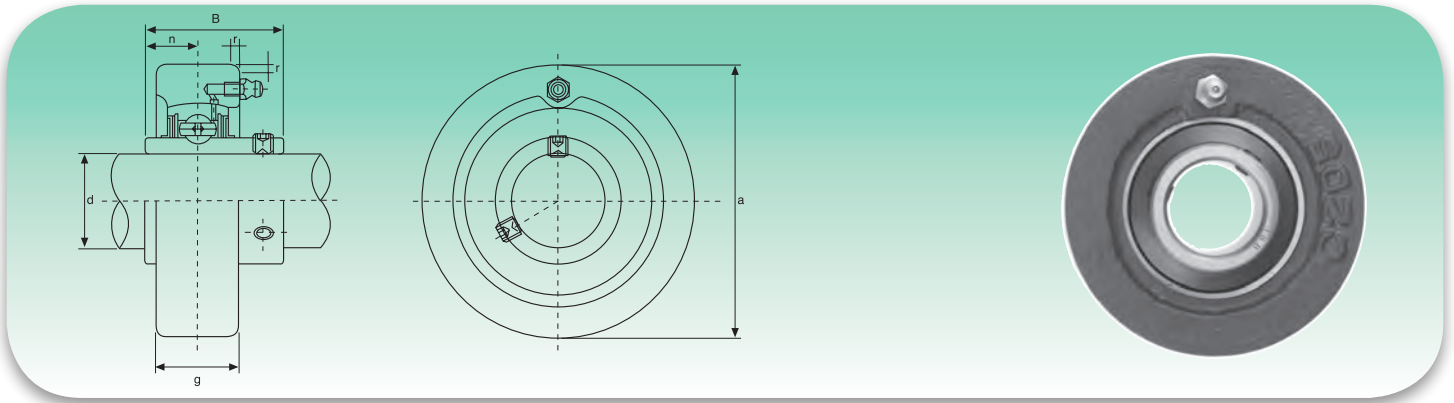

Tipo Type	Dimensiones - Dimensions						Coeficientes de carga (N) Load ratings (N)		Rodamiento Bearing	Soporte Housing	Peso Weight
	d	a	g	r	B	n	Dinámica C Dynamic C	Estática C _o Static C _o			
	mm/inch										kg
UCC201	12	72	20	2	31	12,7	12160	6318	UC201	C204	0,52
UCC201-8	3/7	2,8346	25/32	0,079	1,2205	0,500			UC201-8		0,51
UCC202	15	72	20	2	31	12,7	12160	6318	UC202	C204	0,51
UCC202-9	9/16	2,8346	25/32	0,079	1,2205	0,500			UC202-9		0,51
UCC202-10	5/8						UC202-10	0,51			
UCC203	17	72	20	2	31	12,7	12160	6318	UC203	C204	0,50
UCC203-11	11/16	2,8346	25/32	0,079	1,2205	0,500			UC203-11		0,49
UCC204	20	72	20	2	31	12,7	12160	6318	UC204	C204	0,48
UCC204-12	3/4	2,8346	25/32	0,079	1,2205	0,500			UC204-12		0,48
UCC205	25	80	22	2	34,1	14,3	13300	7457	UC205	C205	0,63
UCC205-13	13/16	3,1496	55/64	0,079	1,3425	0,563			UC205-13		0,67
UCC205-14	7/8								UC205-14		0,66
UCC205-15	15/16								UC205-15		0,64
UCC205-16	1								UC205-16		0,63
UCC206	30						85	27	2	38,1	15,9
UCC206-17	11/16	3,3465	11/16	0,079	1,5000	0,626	UC206-17	0,83			
UCC206-18	11/8						UC206-18	0,82			
UCC206-19	13/16						UC206-19	0,80			
UCC206-20	1 1/4						UC206-20	0,79			
UCC207	35						90	28	2	42,9	17,5
UCC207-20	1 1/4	3,5433	17/64	0,079	1,6890	0,689	UC207-20	0,99			
UCC207-21	15/16						UC207-21	0,96			
UCC207-22	13/8						UC207-22	0,93			
UCC207-23	17/16						UC207-23	0,90			
UCC208	40						100	30	2,5	49,2	19
UCC208-24	1 1/2	3,9370	13/16	0,098	1,9370	0,748	UC208-24	1,26			
UCC208-25	19/16						UC208-25	1,23			
UCC209	45						110	31	2,5	49,2	19
UCC209-26	15/8	4,3307	17/32	0,098	1,9370	0,748	UC209-26	1,59			
UCC209-27	111/16						UC209-27	1,55			
UCC209-28	1 3/4						UC209-28	1,51			
UCC210	50						120	33	2,5	51,6	19
UCC210-29	113/16	4,7244	119/64	0,098	2,0315	0,748	UC210-29	2,02			
UCC210-30	17/8						UC210-30	1,97			
UCC210-31	115/16						UC210-31	1,92			
UCC210-32	2						UC210-32	1,88			
UCC211	55						125	35	2,5	55,6	22,2
UCC211-32	2	4,9213	13/8	0,098	2,1890	0,874	UC211-32	2,33			
UCC211-33	21/16						UC211-33	2,27			
UCC211-34	21/8						UC211-34	2,22			
UCC211-35	23/16						UC211-35	2,16			
UCC212	60						130	38	2,5	65,1	25,4
UCC212-36	2 1/4	5,1181	1 1/2	0,098	2,5630	1,000	UC212-36	2,65			
UCC212-37	25/16						UC212-37	2,57			
UCC212-38	23/8						UC212-38	2,50			
UCC212-39	27/16						UC212-39	2,43			
UCC213	65						140	40	3	65,1	25,4
UCC213-40	2 1/2	5,5118	137/64	0,118	2,5630	1,000	UC213-40	3,07			
UCC213-41	29/16						UC213-41	2,98			

Disponibile en acero inox. Soporte: AISI 304 - Rodamiento: AISI 440C - Available stainless steel Housing: AISI 304 - Bearing: AISI 440C
 Disponibile a petición con rodamiento SA (SACC) - Available under request with SA bearing (SACC)

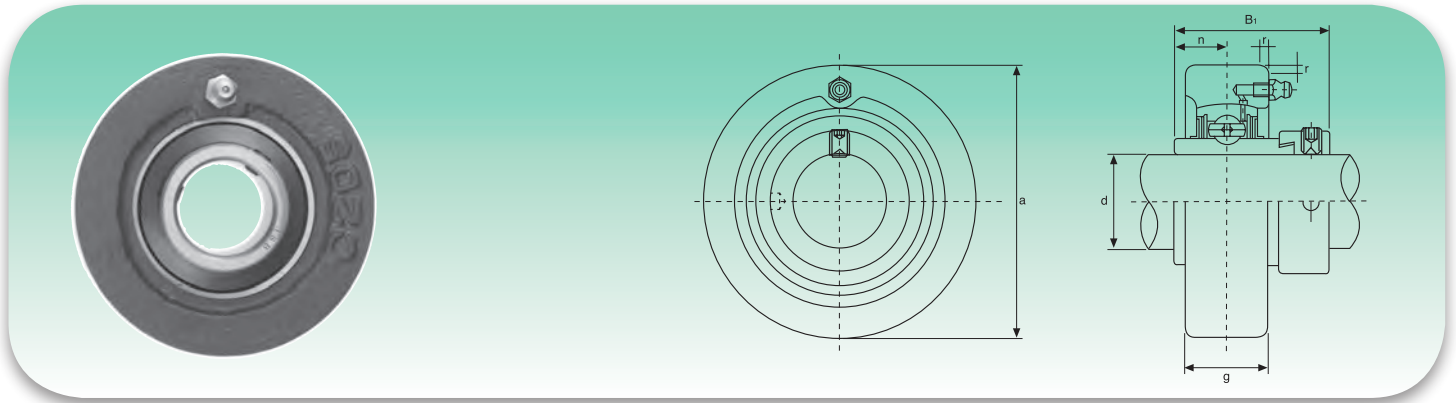
HCC2 Serie normal - Normal duty

Tipo Type	Dimensiones - Dimensions						Coeficientes de carga (N) Load ratings (N)		Rodamiento Bearing	Soporte Housing	Peso Weight
	d	a	g	r	B ₁	n	Dinámica C Dynamic C	Estática C ₀ Static C ₀			
	mm/inch										
HCC204	20	72	20	2	43,7	17,1	12160	6318	HC204	C204	0,55
HCC204-12	¾	2,8346	25/32	0,079	1,720	0,673			0,55		
HCC205	25	80	22	2	44,4	17,5	13300	7457	HC205	C205	0,70
HCC205-13	13/16	3,1496	55/64	0,079	1,748	0,689			0,75		
HCC205-14	7/8								0,74		
HCC205-15	15/16								0,72		
HCC205-16	1								0,70		
HCC206	30						85	27	2	48,4	18,3
HCC206-17	11/16	3,3465	11/16	0,079	1,906	0,720	0,98				
HCC206-18	11/8						0,95				
HCC206-19	13/16						0,93				
HCC206-20	1¼						0,90				
HCC207	35						90	28	2	51,1	18,8
HCC207-20	1¼	3,5433	17/64	0,079	2,012	0,740	1,12				
HCC207-21	15/16						1,08				
HCC207-22	13/8						1,05				
HCC207-23	17/16						1,02				
HCC208	40						100	30	2,5	56,3	21,4
HCC208-24	1½	3,9370	13/16	0,098	2,217	0,843	1,42				
HCC208-25	19/16						1,38				
HCC209	45						110	31	2,5	56,3	21,4
HCC209-26	15/8	4,3307	17/32	0,098	2,217	0,843	1,77				
HCC209-27	111/16						1,72				
HCC209-28	1¾						1,68				
HCC210	50						120	33	2,5	62,7	24,6
HCC210-29	113/16	4,7244	119/64	0,098	2,469	0,969	2,24				
HCC210-30	17/8						2,18				
HCC210-31	115/16						2,12				
HCC210-32	2						2,06				
HCC211	55						125	35	2,5	71,4	27,8
HCC211-32	2	4,9213	13/8	0,098	2,811	1,094	2,59				
HCC211-33	22/16						2,51				
HCC211-34	21/8						2,44				
HCC211-35	23/16						2,36				
HCC212	60						130	38	2,5	77,8	31
HCC212-36	2¼	5,1181	1½	0,098	3,063	1,220	3,02				
HCC212-37	25/16						2,93				
HCC212-38	23/8						2,88				
HCC212-39	27/16						2,75				

UCC3 Serie media - Medium duty

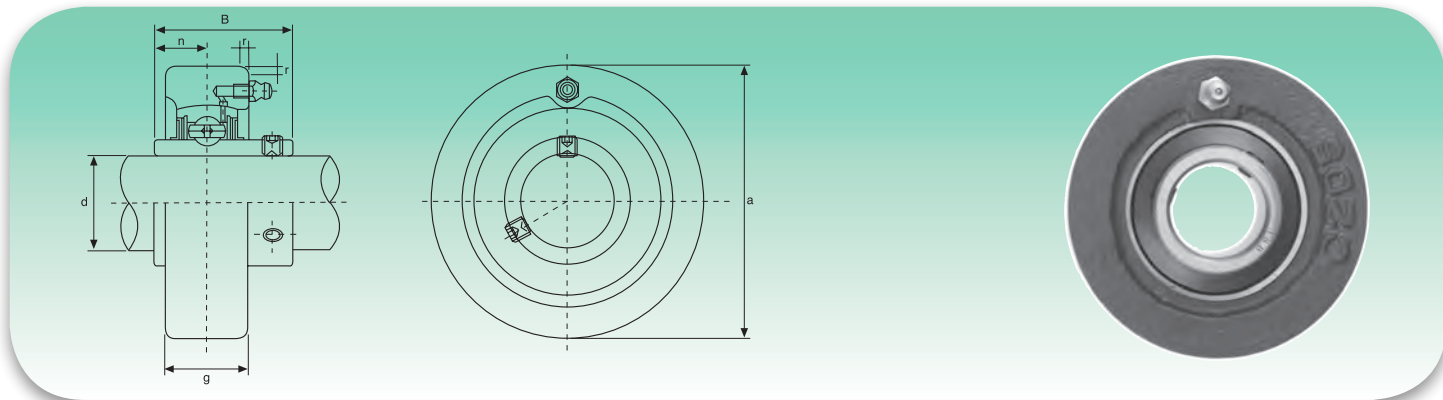

Tipo Type	Dimensiones - Dimensions						Coeficientes de carga (N) Load ratings (N)		Rodamiento Bearing	Soporte Housing	Peso Weight
	d	a	g	r	B	n	Dinámica C Dynamic C	Estática C ₀ Static C ₀			
	mm/inch										kg
UCC305	25	90	26	2,5	38	15			UC305		1,10
UCC305-13	13/16								UC305-13		1,15
UCC305-14	7/8	3,5433	11/32	0,098	1,4961	0,591	20140	10355	UC305-14	C305	1,13
UCC305-15	15/16								UC305-15		1,11
UCC305-16	1								UC305-16		1,10
UCC306	30	100	28	2,5	43	17			UC306		1,40
UCC306-17	11/16								UC306-17		1,45
UCC306-18	11/8	3,9370	17/64	0,098	1,6929	0,669	25365	14250	UC306-18	C306	1,42
UCC306-19	13/16								UC306-19		1,40
UCC307	35	110	32	3	48	19			UC307		1,80
UCC307-20	1 1/4								UC307-20		1,86
UCC307-21	15/16								UC307-21	C307	1,83
UCC307-22	13/8	4,3307	11/64	0,118	1,8897	0,748	31730	18335	UC307-22		1,80
UCC307-23	17/16								UC307-23		1,78
UCC308	40	120	34	3	52	19			UC308		2,20
UCC308-24	1 1/2								UC308-24		2,25
UCC308-25	19/16	4,7244	111/32	0,118	2,0472	0,748	38665	22800	UC308-25	C308	2,21
UCC309	45	130	38	3,5	57	22			UC309		2,70
UCC309-26	15/8								UC309-26		2,81
UCC309-27	111/16	2,1181	1 1/2	0,138	2,441	0,866	46455	28025	UC309-27	C309	2,77
UCC309-28	1 3/4								UC309-28		2,72
UCC310	50	140	40	3,5	61	22			UC310		3,30
UCC310-29	113/16								UC310-29		3,62
UCC310-30	17/8	5,118	137/64	0,138	2,4015	0,866	58900	36385	UC310-30	C310	3,39
UCC310-31	115/16								UC310-31		3,33
UCC311	55	150	44	3,5	66	25			UC311		3,90
UCC311-32	2								UC311-32		1,08
UCC311-33	21/16								UC311-33	C311	4,01
UCC311-34	21/8	5,9055	147/64	0,138	2,5984	0,984	68020	42750	UC311-34		3,95
UCC311-35	23/16								UC311-35		3,87
UCC312	60	160	46	3,5	71	26			UC312		4,80
UCC312-36	2 1/4								UC312-36		4,95
UCC312-37	25/16								UC312-37	C312	4,87
UCC312-38	23/8	6,2992	113/16	0,138	2,7953	1,024	77805	49590	UC312-38		4,78
UCC312-39	27/16								UC312-39		4,70
UCC313	65	170	50	3,5	75	30			UC313		5,80
UCC313-40	2 1/2								UC313-40		5,89
UCC313-41	29/16	6,6929	131/32	0,138	2,9528	1,181	88065	56905	UC313-41	C313	5,89
UCC314	70	180	52	4	78	33			UC314		6,60
UCC314-42	25/8								UC314-42		6,82
UCC314-43	211/16	7,0866	23/64	0,157	3,0709	1,299	98800	64790	UC314-43	C314	6,71
UCC314-44	2 3/4								UC314-44		6,61
UCC315	75	190	55	4	82	32			UC315		7,80
UCC315-45	213/16								UC315-45		8,07
UCC315-46	27/8	7,4803	211/64	0,157	3,2288	1,260	107350	73340	UC315-46	C315	7,93
UCC315-47	215/16								UC315-47		7,84
UCC315-48	3								UC315-48		7,71
UCC316	80	200	60	4	86	34			UC316		9,05
UCC316-49	31/16								UC316-49		9,22
UCC316-50	31/8	7,8740	223/64	0,157	3,3858	1,339	116850	82365	UC316-50	C316	9,08
UCC316-51	33/16								UC316-51		8,99
UCC317	85	215	64	4	96	40			UC317		10,97
UCC317-52	3 1/4								UC317-52		11,19
UCC317-53	35/16	8,4646	234/64	0,157	3,7795	1,575	126350	91960	UC317-53	C317	11,06
UCC317-54	37/16								UC317-54		10,74
UCC318	90	225	66	4	96	40			UC318		11,96
UCC318-55	37/16								UC318-55		12,25
UCC318-56	3 1/2	8,8583	216/32	0,157	3,7795	1,575	135850	101650	UC318-56	C318	12,07
UCC319	95	240	66	4	103	41			UC319		15,00
UCC319-58	35/8								UC319-58		15,33
UCC319-59	311/16	9,4488	253/64	0,157	4,0551	1,614	145350	113050	UC319-59	C319	15,15
UCC319-60	3 3/4								UC319-60		14,96
UCC320	100	260	75	4	108	42			UC320		19,6
UCC320-64	4	10,2362	261/64	0,157	4,2519	1,645	164350	133950	UC320-64	C320	19,4
UCC322	110	320	90	5	126	46			UC322		29,2
		11,8110	32/32	0,197	4,6063	1,811	194750	171000		C322	
UCC324	120	370	290	5	40	51			UC324		35,9
		12,5984	335/64	0,197	4,9606	2,008	196650	175750		C324	
UCC326	130	340	100	5	135	54			UC326		43,0
		13,3858	315/16	0,197	5,3150	2,126	217550	203300		C326	
UCC328	140	360	100	5	145	59			UC328		52,9
		14,1732	315/16	0,197	5,7086	3,323	240350	233700		C328	

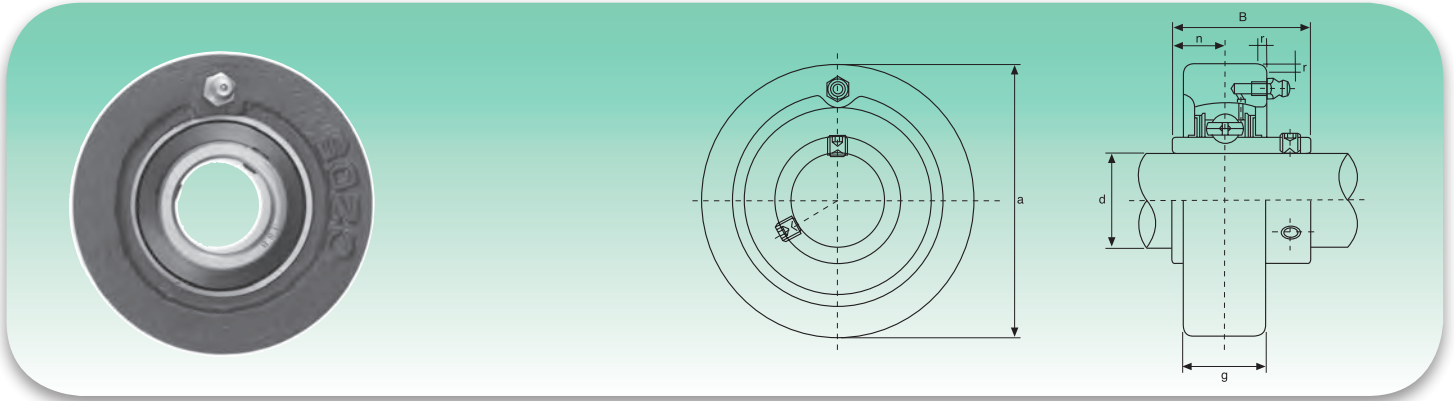
UCCX Serie media - Medium duty

Tipo Type	Dimensiones - Dimensions						Coeficientes de carga (N) Load ratings (N)		Rodamiento Bearing	Soporte Housing	Peso Weight kg
	d	a	g	r	B	n	Dinámica C Dynamic C	Estática C _o Static C _o			
	mm/inch										
UCCX05	25	90	27	2	38,1	15,9	18525	10735	UCX05	CX05	1,1
UCCX05-13	13/16										
UCCX05-14	7/8	3,5433	11/16	0,079	1,5000	0,626					
UCCX05-15	15/16										
UCCX05-16	1										
UCCX06	30	100	30	2,5	42,9	17,5	24415	14630	UCX06	CX06	1,6
UCCX06-17	11/16										
UCCX06-18	11/8	3,9370	13/16	0,098	1,6890	0,689					
UCCX06-19	13/16										
UCCX06-20	1¼										
UCCX07	35	110	34	2,5	49,2	19	27645	16910	UCX07	CX07	2,0
UCCX07-21	15/16										
UCCX07-22	13/8	4,3307	111/32	0,098	1,9370	0,748					
UCCX07-23	17/16										
UCCX08	40	120	38	2,5	49,2	19	32395	20235	UCX08	CX08	2,5
UCCX08-24	1½	4,7244	1½	0,098	1,9370	0,748					
UCCX08-25	19/16										
UCCX09	45	120	38	2,5	51,6	19	33345	22135	UCX09	CX09	2,4
UCCX09-26	15/8										
UCCX09-27	111/16	4,7244	1½	0,098	2,0315	0,748					
UCCX09-28	1¾										
UCCX09-29	113/16										
UCCX10	50	130	40	2,5	55,6	22,2	41230	27930	UCX10	CX10	3,0
UCCX10-30	17/8										
UCCX10-31	115/16	5,1181	137/64	0,098	2,1890	0,874					
UCCX10-32	2										
UCCX11	55	150	42	3	65,1	25,4	49780	34390	UCX11	CX11	4,4
UCCX11-33	21/16										
UCCX11-34	21/8										
UCCX11-35	23/16	5,9055	121/32	0,118	2,5630	1,000					
UCCX11-36	2¼										
UCCX11-37	25/16										
UCCX12	60	160	44	3	65,1	25,4	54340	38095	UCX12	CX12	5,0
UCCX12-38	23/8	6,2992	147/64	0,118	2,5630	1,000					
UCCX12-39	27/16										

UKC2 Serie normal - Standard duty

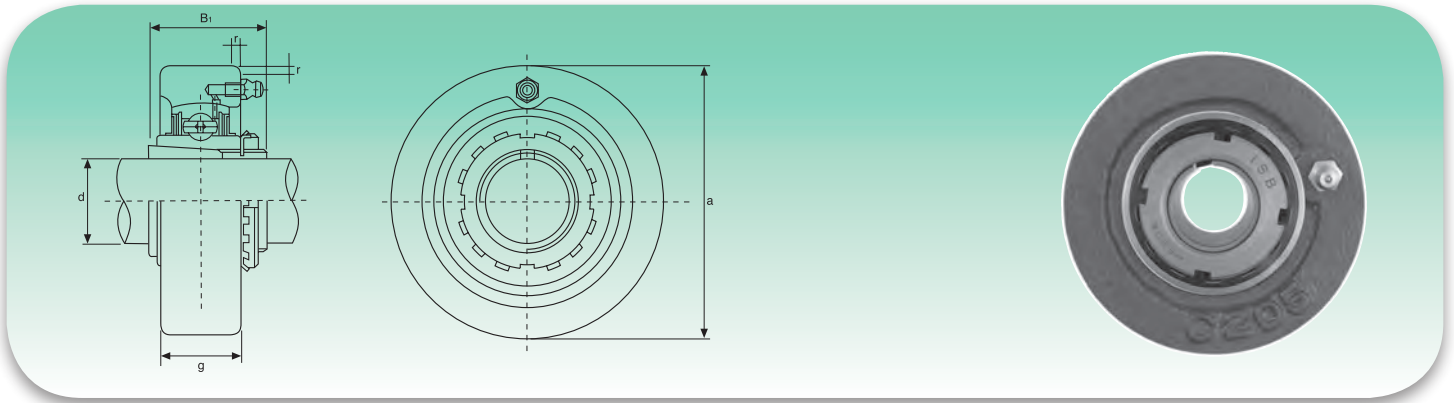

Tipo Type	Dimensiones - Dimensions					Coeficientes de carga (N) Load ratings (N)		Rodamiento Bearing	Soporte Housing	Peso Weight
	d	a	g	r	B ₁	Dinámica C Dynamic C	Estática C ₀ Static C ₀			
	mm/inch									kg
UKC205+H2305	20	80	22	2	35	13300	7457	UK205+H2305	C205	0,68
UKC205+HE2305	¾	3,1496	55/64	0,079	1,378			UK205+HE2305		
UKC206+H2306	25	85	27	2	38	18525	10735	UK206+H2306	C206	0,84
UKC206+HS2306	7/8	3,3465	11/16	0,079	1,496			UK206+HS2306		
UKC206+HE2306	1							UK206+HE2306		
UKC207+H2307	30	90	28	2	43	24415	14630	UK207+H2307	C207	1,02
UKC207+HS2307	11/8	3,5433	17/64	0,079	1,693			UK207+HS2307		
UKC208+H2308	35	100	30	2,5	46	27645	16910	UK208+H2308	C208	1,32
UKC208+HE2308	1¼	3,9370	13/16	0,098	1,811			UK208+HE2308		
UKC208+HS2308	13/8							UK208+HS2308		
UKC209+H2309	40	110	31	2,5	50	32395	20235	UK209+H2309	C209	1,64
UKC209+HA2309	17/16	4,3307	17/32	0,098	1,969			UK209+HA2309		
UKC209+HE2309	1½							UK209+HE2309		
UKC209+HS2309	15/8							UK209+HS2309		
UKC210+H2310	45	120	33	2,5	55	33345	22135	UK210+H2310	C210	2,07
UKC210+HS2310	15/8	4,7244	119/64	0,098	2,165			UK210+HS2310		
UKC210+HA2310	111/16							UK210+HA2310		
UKC210+HE2310	1¾							UK210+HE2310		
UKC211+H2311	50	125	35	2,5	59	41230	27930	UK211+H2311	C211	2,33
UKC211+HS2311	17/8	4,9213	13/6	0,098	2,323			UK211+HS2311		
UKC211+HA2311	115/16							UK211+HA2311		
UKC211+HE2311	2							UK211+HE2311		
UKC212+H2312	55	130	38	2,5	62	49780	34390	UK212+H2312	C212	2,57
UKC212+HS2312	21/8	5,1181	1½	0,098	2,441			UK212+HS2312		
UKC213+H2313	60	140	40	3	65	54340	38095	UK213+H2313	C213	2,89
UKC213+HA2313	23/16	5,5118	137/64	0,118	2,559			UK213+HA2313		
UKC213+HE2313	2¼							UK213+HE2313		
UKC213+HS2313	23/8							UK213+HS2313		

Manguitos HA; HE; HS con rosca en pulgadas
Inch dimension adapter sleeves HA; HE; HS

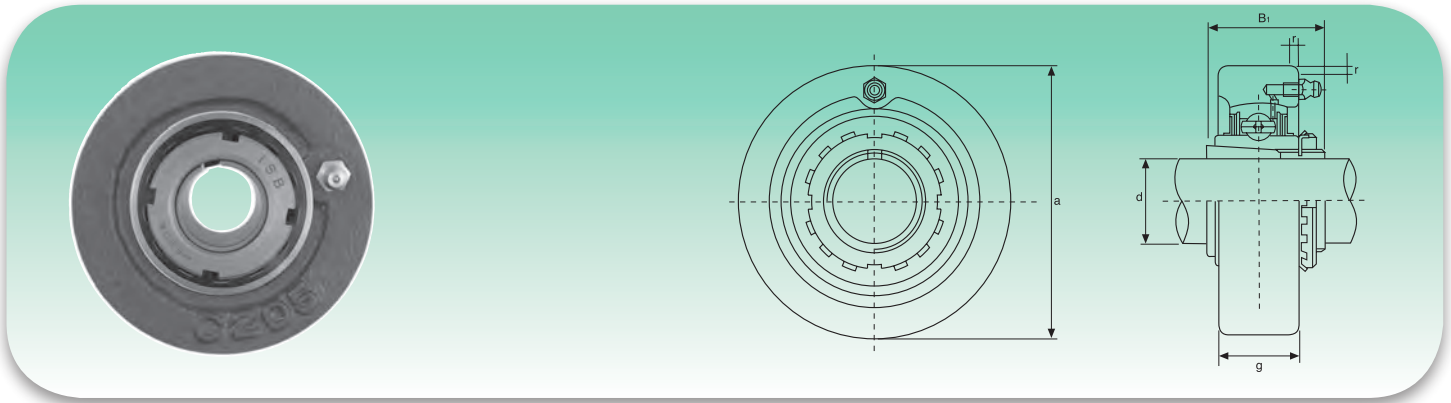
UKCX Serie media - Medium duty

Tipo Type	Dimensiones - Dimensions					Coeficientes de carga (N) Load ratings (N)		Rodamiento Bearing	Soporte Housing	Peso Weight kg
	d	a	g	r	B ₁	Dinámica C Dynamic C	Estática C ₀ Static C ₀			
	mm/inch									
UKCX05+H2305	20	90	27	2	35	18525	10735	UKX05+H2305	CX05	0,99
UKCX05+HE2305	¾	3,5433	11/16	0,079	1,378			UKX05+HE2305		
UKCX06+H2306	25	100	30	2,5	38	24415	14630	UKX06+H2306	CX06	1,3
UKCX06+HS2306	7/8	3,9370	13/16	0,098	1,496			UKX06+HS2306		
UKCX06+HE2306	1							UKX06+HE2306		
UKCX07+H2307	30	110	34	2,5	43	27645	16910	UKX07+H2307	CX07	1,7
UKCX07+HS2307	11/8	4,3307	111/32	0,098	1,693			UKX07+HS2307		
UKCX08+H2308	35	120	38	2,5	46	32395	20235	UKX08+H2308	CX08	2,3
UKCX08+HE2308	1¼	4,7244	1½	0,098	1,811			UKX08+HE2308		
UKCX08+HS2308	13/8							UKX08+HS2308		
UKCX09+H2309	40	120	38	2,5	50	33345	22135	UKX09+H2309	CX09	2,3
UKCX09+HA2309	17/16	4,7244	1½	0,098	1,969			UKX09+HA2309		
UKCX09+HE2309	1½							UKX09+HE2309		
UKCX09+HS2309	15/8							UKX09+HS2309		
UKCX10+H2310	45	130	40	2,5	55	41230	27930	UKX10+H2310	CX10	2,8
UKCX10+HS2310	15/8	5,1181	137/64	0,098	2,165			UKX10+HS2310		
UKCX10+HA2310	111/16							UKX10+HA2310		
UKCX10+HE2310	1¾							UKX10+HE2310		
UKCX11+H2311	50	150	42	3	59	49780	34390	UKX11+H2311	CX11	3,8
UKCX11+HS2311	117/8	5,9055	121/32	0,118	2,323			UKX11+HS2311		
UKCX11+HA2311	115/16							UKX11+HA2311		
UKCX11+HE2311	2							UKX11+HE2311		
UKCX12+H2312	55	130	38	2,5	62	54340	38095	UKX12+H2312	CX12	4,4
UKCX12+HS2312	21/8	6,2992	123/32	0,118	2,441			UKX12+HS2312		

Manguitos HA; HE; HS con rosca en pulgadas
Inch dimension adapter sleeves HA; HE; HS

UCPH2 Serie normal - Standard duty

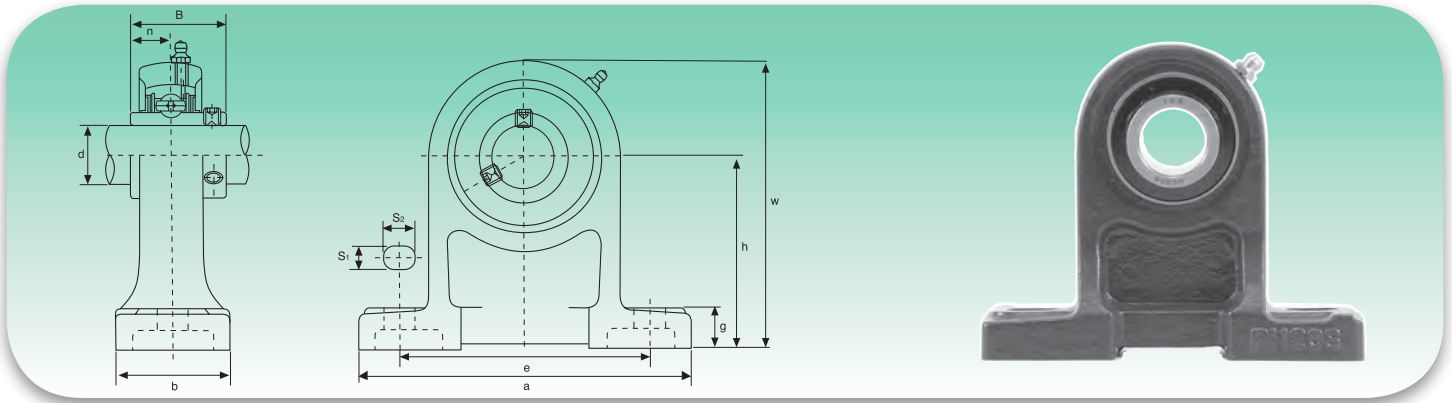

Tipo Type	Dimensiones - Dimensions											Bul. fij. Bolt Size	Coeficientes de carga (N) Load ratings (N)		Rodamiento Bearing	Soporte Housing	Peso Weight	
	d	h	a	e	b	S ₁	S ₂	g	w	B	n		Dinámica C Dynamic C	Estática C ₀ Static C ₀				kg
	mm/inch												mm/inch					
UCPH201	12	70	127	95	40	13	19	15	101	31	12,7	M10	12160	6318	UC201 UC201-8	PH203	0,81	
UCPH201-8	3/4	2 3/4	5	3 3/4	1 9/16	1/2	3/4	19/32	363/64	1,2205	0,500	3/8					0,80	
UCPH202	15	70	127	95	40	13	19	15	101	31	12,7	M10	12160	6318	UC202 UC202-9 UC202-10	PH203	0,80	
UCPH202-9	9/16	2 3/4	5	3 3/4	1 9/16	1/2	3/4	19/32	363/64	1,2205	0,500	3/8					0,80	
UCPH202-10	5/8																0,80	
UCPH203	17	70	127	95	40	13	19	15	101	31	12,7	M10	12160	6318	UC203 UC203-11	PH203	0,79	
UCPH203-11	1 1/16	2 3/4	5	3 3/4	1 9/16	1/2	3/4	19/32	363/64	1,2205	0,500	3/8					0,78	
UCPH204	20	70	127	95	40	13	19	15	101	31	12,7	M10	12160	6318	UC204 UC204-12	PH204	0,77	
UCPH204-12	3/4	2 3/4	5	3 3/4	1 9/16	1/2	3/4	19/32	363/64	1,2205	0,500	3/8					0,77	
UCPH205	25	80	140	105	50	13	19	16	114	34,1	14,3	M10	13300	7457	UC205 UC205-13 UC205-14 UC205-15 UC205-16	PH205	1,01	
UCPH205-13	13/16																1,05	
UCPH205-14	7/8																1,04	
UCPH205-15	15/16	35/32	5 1/2	41/8	131/32	1/2	3/4	5/8	431/64	1,3425	0,563	3/8					1,02	
UCPH205-16	1																1,01	
UCPH206	30	90	161	121	50	17	21	17	130	38,1	15,9	M14					18525	10735
UCPH206-17	1 1/16												1,50					
UCPH206-18	1 1/8												1,49					
UCPH206-19	13/16	335/64	611/32	4 3/4	131/32	43/64	53/64	43/64	51/8	1,5000	0,626	1/2	1,47					
UCPH206-20	1 1/4												1,46					
UCPH207	35	95	166	127	60	17	21	18	140	42,9	17,5	M14	24415	14630	UC207 UC207-20 UC207-21 UC207-22 UC207-23	PH207	1,91	
UCPH207-20	1 1/4																1,97	
UCPH207-21	15/16																1,94	
UCPH207-22	13/8	347/64	617/32	5	223/64	43/64	53/64	45/64	533/64	1,6890	0,689	1/2					1,91	
UCPH207-23	17/16																1,88	
UCPH208	40	100	178	137	70	17	21	19	150	49,2	19	M14	27645	16910	UC208 UC208-24 UC208-25	PH208	2,52	
UCPH208-24	1 1/2																2,56	
UCPH208-25	19/16	315/16	71/64	513/32	2 3/4	43/64	53/64	3/4	529/32	1,9370	0,748	1/2					2,53	
UCPH209	45	105	189	146	70	17	21	20	158	49,2	19	M14	32395	20235	UC209 UC209-26 UC209-27 UC209-28	PH209	2,72	
UCPH209-26	15/8																2,82	
UCPH209-27	111/16	49/64	77/16	5 3/4	2 3/4	43/64	53/64	25/32	67/32	1,9370	0,748	1/2					2,78	
UCPH209-28	1 3/4																2,74	
UCPH210	50	110	205	159	70	20	23	21	165	51,6	19	M16	33345	22135	UC210 UC210-29 UC210-30 UC210-31 UC210-32	PH210	3,10	
UCPH210-29	113/16																3,22	
UCPH210-30	17/8																3,17	
UCPH210-31	115/16	421/64	85/64	6 1/4	2 3/4	25/32	29/32	53/64	6 1/2	2,0315	0,748	5/8					3,12	
UCPH210-32	2																3,08	
UCPH211	55	120	219	171	75	20	23	22	181	55,6	22,2	M16	41230	27930	UC211 UC211-32 UC211-33 UC211-34 UC211-35	PH211	-	
UCPH211-32	2																-	
UCPH211-33	21/16																-	
UCPH211-34	21/8	423/32	85/8	647/64	261/64	25/32	29/32	55/64	71/8	2,1890	0,874	5/8					-	
UCPH211-35	23/16																-	
UCPH212	60	130	241	184	85	20	23	25	197	65,1	25,4	M16	49780	34390	UC212 UC212-36 UC212-37 UC212-38 UC212-39	PH212	-	
UCPH212-36	2 1/4																-	
UCPH212-37	25/16																-	
UCPH212-38	23/8	51/8	9 1/2	7 1/4	311/32	25/32	29/32	63/64	7 3/4	2,5630	1,000	5/8					-	
UCPH212-39	27/16																-	
UCPH213	65	140	265	203	95	25	28	27	212	65,1	25,4	M20	54340	38095	UC213 UC213-40 UC213-41	PH213	-	
UCPH213-40	2 1/2																-	
UCPH213-41	29/16	533/64	107/16	8	3 3/4	63/64	13/32	11/16	811/32	2,5630	1,000	3/4					-	
UCPH214	70	150	266	210	105	25	28	28	225	74,6	30,2	M20	59090	41895	UC214 UC214-42 UC214-43 UC214-44	PH214	-	
UCPH214-42	25/8																-	
UCPH214-43	211/16	529/32	1015/32	817/64	59/64	63/64	13/32	17/64	855/64	2,9370	1,189	3/4					-	
UCPH214-44	2 3/4																-	
UCPH215	75	160	275	217	115	25	28	29	238	77,8	33,3	M20	64030	45885	UC215 UC215-45 UC215-46 UC215-47 UC215-48	PH215	-	
UCPH215-45	213/16																-	
UCPH215-46	27/8																-	
UCPH215-47	215/16	519/64	1053/64	835/64	417/32	63/64	13/32	19/64	93/8	3,0630	1,311	3/4					-	
UCPH215-48	3																-	
UCPH216	80	170	292	232	125	25	28	30	253	82,6	33,3	M20	69065	50350	UC216 UC216-49 UC216-50 UC216-51	PH216	-	
UCPH216-49	31/16																-	
UCPH216-50	31/8	611/16	11 1/2	91/8	459/64	63/64	13/32	13/16	961/64	3,2520	1,311	3/4					-	
UCPH216-51	33/16																-	

Disponibile en acero inox. Soporte: AISI 304 - Rodamiento: AISI 440C - Available stainless steel Housing: AISI 304 - Bearing: AISI 440C
 Disponible a petición con rodamiento SA (SAPH) - Available under request with SA bearing (SAPH)

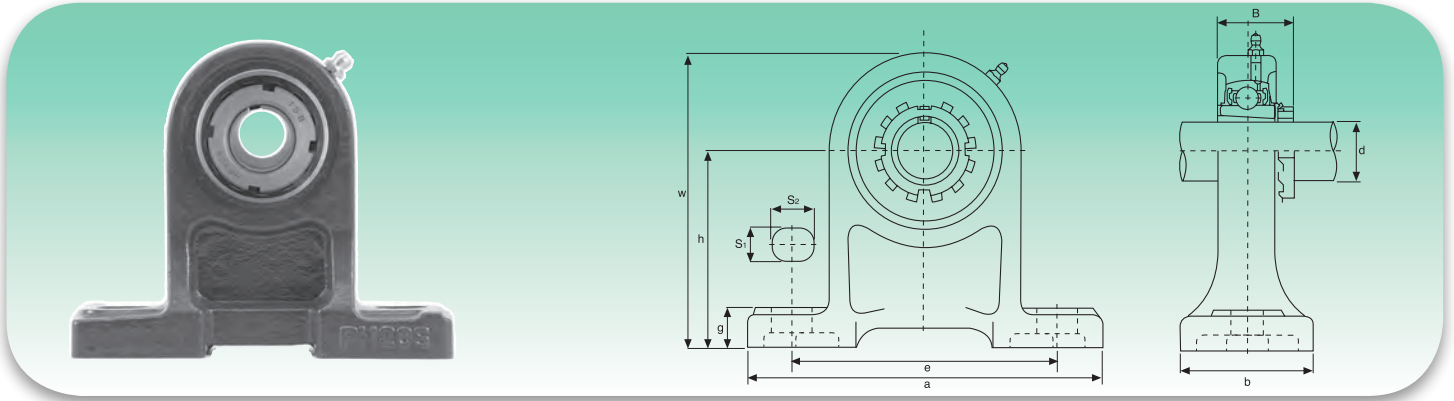
UKPH2 Serie normale - Standard duty

Tipo Type	Dimensiones - Dimensions										Bul. fij. Bolt Size	Coeficientes de carga (N) Load ratings (N)		Rodamiento Bearing	Soporte Housing	Peso Weight	
	d	h	a	e	b	S ₁	S ₂	g	w	B ₁		Dinámica C Dynamic C	Estática C ₀ Static C ₀				kg
	mm/inch											mm/inch					
UKPH205+H2305	20	80	140	105	50	13	19	16	114	34,1	M10	13300	7457	UK205+H2305	PH205	1,24	
UKPH205+HE2305	¾	35/32	5½	41/8	131/32	½	¾	5/8	431/64	1,3425	3/8			UK205+HE2305			
UKPH206+H2306	25	90	161	121	50	17	21	17	130	38,1	M14	18525	10735	UK206+H2306	PH206	1,64	
UKPH206+HS2306	7/8	335/64	611/32	4¾	131/32	43/64	53/64	43/64	51/8	1,5000	½			UK206+HS2306			
UKPH206+HE2306	1													UK206+HE2306			
UKPH207+H2307	30	95	166	127	60	17	21	18	140	42,9	M14	24415	14630	UK207+H2307	PH207	2,03	
UKPH207+HS2307	11/8	347/64	617/32	5	223/64	43/64	53/64	45/64	533/64	1,6890	½			UK207+HS2307			
UKPH208+H2308	35	100	178	137	70	17	21	19	150	49,2	M14	27645	16910	UK208+H2308	PH208	2,72	
UKPH208+HE2308	1¼	315/16	71/64	512/32	2¾	43/64	53/64	¾	529/32	1,9370	½			UK208+HE2308			
UKPH208+HS2308	13/8													UK208+HS2308			
UKPH209+H2309	40	105	189	146	70	17	21	20	158	49,2	M14	32395	20235	UK209+H2309	PH209	3,09	
UKPH209+HA2309	17/16	49/64	77/16	5¾	2¾	43/64	53/64	25/32	67/32	1,9370	½			UK209+HA2309			
UKPH209+HE2309	1½													UK209+HE2309			
UKPH209+HS2309	15/8													UK209+HS2309			
UKPH210+H2310	45	110	205	159	70	20	23	21	165	51,6	M16	33345	22135	UK210+H2310	PH210	3,59	
UKPH210+HS2310	15/8	421/64	85/64	6¼	2¾	25/32	29/32	53/64	6½	2,0315	5/8			UK210+HS2310			
UKPH210+HA2310	111/16													UK210+HA2310			
UKPH210+HE2310	1¾													UK210+HE2310			

Manguitos HA; HE; HS con rosca en pulgadas
Inch dimension adapter sleeves HA; HE; HS

UCPA2 Serie normal - Standard duty

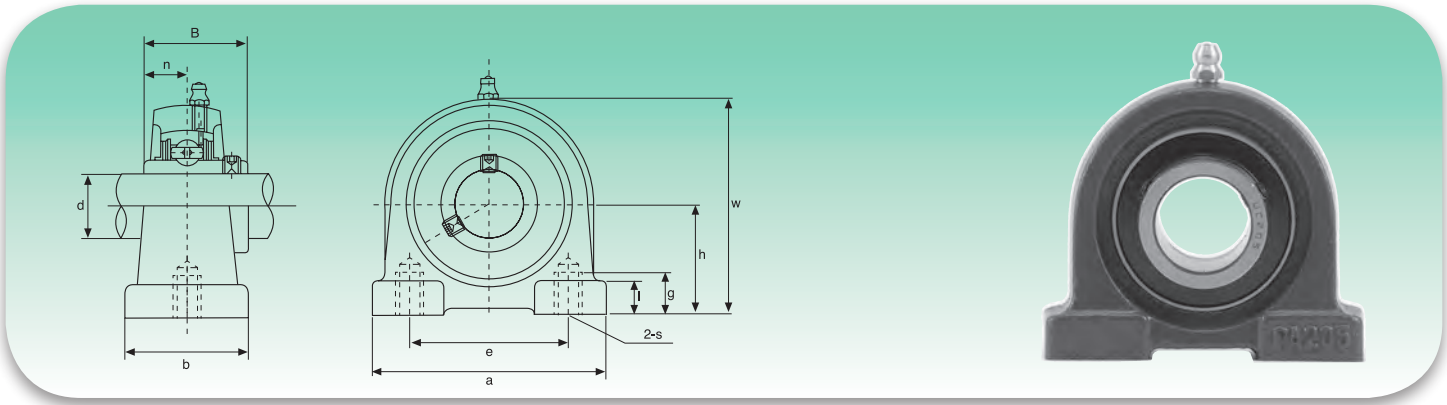

Tipo Type	Dimensiones - Dimensions										Bul. fj. Bolt Size	Coeficientes de carga (N) Load ratings (N)		Rodamiento Bearing	Soporte Housing	Peso Weight	
	d	h	a	e	b	g	l	w	B	n		Dinámica C Dynamic C	Estática C ₀ Static C ₀				kg
	mm/inch											mm/inch					
UCPA201 UCPA201-8	12 3/4	30,2 13/16	76 3	52 23/64	40 19/16	15 19/32	11 7/16	62 27/16	31 1,2205	12,7 0,500	M10 3/8	12160	6318	UC201 UC201-8	PA204	0,60 0,59	
UCPA202 UCPA202-9 UCPA202-10	15 9/16 5/8	30,2 13/16	76 3	52 23/64	40 19/16	15 19/32	11 7/16	62 27/16	31 1,2205	12,7 0,500	M10 3/8	12160	6318	UC202 UC202-9 UC202-10	PA204	0,59 0,59 0,59	
UCPA203 UCPA203-11	17 11/16	30,2 13/16	76 3	52 23/64	40 19/16	15 19/32	11 7/16	62 27/16	31 1,2205	12,7 0,500	M10 3/8	12160	6318	UC203 UC203-11	PA204	0,58 0,57	
UCPA204 UCPA204-12	20 3/4	30,2 13/16	76 3	52 23/64	40 19/16	15 19/32	11 7/16	62 27/16	31 1,2205	12,7 0,500	M10 3/8	12160	6318	UC204 UC204-12	PA204	0,56 0,56	
UCPA205 UCPA205-13 UCPA205-14 UCPA205-15 UCPA205-16	25 13/16 7/8 15/16 1	36,5 17/16	84 35/16	56 213/64	38 1 1/2	15 19/32	12 15/32	72 253/64	34,1 1,3425	14,3 0,563	M10 3/8	13300	7457	UC205 UC205-13 UC205-14 UC205-15 UC205-16	PA205	0,83 0,87 0,86 0,84 0,83	
UCPA206 UCPA206-17 UCPA206-18 UCPA206-19 UCPA206-20	30 11/16 11/8 13/16 1 1/4	42,9 111/16	94 345/64	66 219/32	50 131/32	18 45/64	12 15/32	84 35/16	38,1 1,5000	15,9 0,626	M14 1/2	18525	10735	UC206 UC206-17 UC206-18 UC206-19 UC206-20	PA206	1,12 1,15 1,14 1,12 1,11	
UCPA207 UCPA207-20 UCPA207-21 UCPA207-22 UCPA207-23	35 1 1/4 15/16 13/8 17/16	47,6 17/8	110 421/64	80 35/32	55 211/64	20 25/32	13 33/64	95 347/64	42,9 1,6890	17,5 0,689	M14 1/2	24415	14630	UC207 UC207-20 UC207-21 UC207-22 UC207-23	PA207	1,48 1,54 1,51 1,48 1,45	
UCPA208 UCPA208-24 UCPA208-25	40 1 1/2 19/16	49,2 115/16	116 49/16	84 35/16	58 29/32	20 25/32	13 33/64	100 315/16	49,2 1,9370	19 0,748	M14 1/2	27645	16910	UC208 UC208-24 UC208-25	PA208	1,89 1,93 1,90	
UCPA209 UCPA209-26 UCPA209-27 UCPA209-28	45 15/8 111/16 1 3/4	54,2 29/64	120 423/32	90 335/64	60 223/64	25 63/64	13 33/64	108 4 1/4	49,2 1,9370	19 0,748	M14 1/2	32395	20235	UC209 UC209-26 UC209-27 UC209-28	PA209	1,98 2,08 2,04 2,00	
UCPA210 UCPA210-29 UCPA210-30 UCPA210-31 UCPA210-32	50 113/16 17/8 115/16 2	57,2 2 1/4	130 51/8	94 345/64	64 233/64	25 63/64	14 35/64	116 49/16	51,6 2,0315	19 0,748	M16 5/8	33345	22135	UC210 UC210-29 UC210-30 UC210-31 UC210-32	PA210	2,16 2,28 2,23 2,18 2,14	
UCPA211 UCPA211-32 UCPA211-33 UCPA211-34 UCPA211-35	55 2 21/16 21/8 23/16	63,5 2 1/2	140 533/64	104 43/32	66 219/32	25 63/64	14 35/64	125 459/64	55,6 2,1890	22,2 0,874	M16 5/8	41230	27930	UC211 UC211-32 UC211-33 UC211-34 UC211-35	PA211	3,26 3,41 3,35 3,30 3,24	
UCPA212 UCPA212-36 UCPA212-37 UCPA212-38 UCPA212-39	60 2 1/4 25/16 23/8 27/16	69,9 2 3/4	150 529/32	114 431/64	68 243/64	25 63/64	15 19/32	138 57/16	65,1 2,5630	25,4 1,000	M16 5/8	49780	34390	UC212 UC212-36 UC212-37 UC212-38 UC212-39	PA212	4,19 4,32 4,24 4,17 4,10	
UCPA213 UCPA213-40 UCPA213-41	65 2 1/2 29/16	76,2 3	160 619/64	124 47/8	70 2 3/4	25 63/64	15 19/32	150 529/32	65,1 2,5630	25,4 1,000	M16 5/8	54340	38095	UC213 UC213-40 UC213-41	PA213	- - -	

Disponibile en acero inox. Soporte: AISI 304 - Rodamiento: AISI 440C - Available stainless steel Housing: AISI 304 - Bearing: AISI 440C
 Disponibile a petizione con rodamiento SA (SAPA) - Available under request with SA bearing (SAPA)

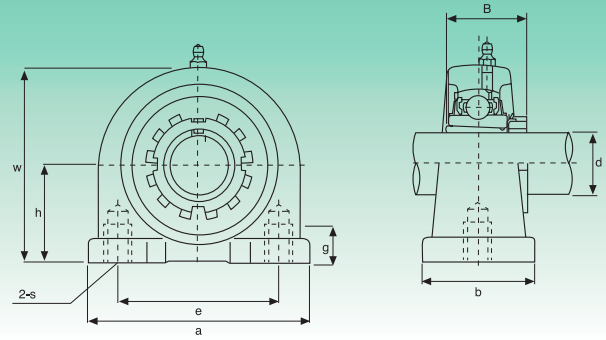
UKPA2 Serie normal - Standard duty

Tipo Type	Dimensiones - Dimensions								Bul. fij. Bolt Size	Coeficientes de carga (N) Load ratings (N)		Rodamiento Bearing	Soporte Housing	Peso Weight kg
	d	h	a	e	b	g	W	B		Dinámica C Dynamic C	Estática C ₀ Static C ₀			
	mm/inch									mm/inch				
UKPA205+H2305	20	36,5	84	56	38	15	72	34,1	M10	13300	7457	UK205+H2305	PA205	0,87
UKPA205+HE2305	¾	17/16	35/16	213/64	1½	19/32	253/64	1,3425	3/8			UK205+HE2305		
UKPA206+H2306	25	42,9	94	66	50	18	84	38,1	M14	18525	10735	UK206+H2306	PA206	1,24
UKPA206+HS2306	7/8	111/16	345/64	219/32	131/32	45/64	35/16	1,5000	½			UK206+HS2306		
UKPA206+HE2306	1											UK206+HE2306		
UKPA207+H2307	30	47,6	110	80	55	20	95	42,9	M14	24415	14630	UK207+H2307	PA207	1,73
UKPA207+HS2307	11/8	17/8	421/64	35/32	211/64	25/32	347/64	1,6890	½			UK207+HS2307		
UKPA208+H2308	35	49,2	116	84	58	20	100	49,2	M14	27645	16910	UK208+H2308	PA208	2,02
UKPA208+HE2308	1¼	115/16	49/16	35/16	29/32	25/32	315/16	1,9370	½			UK208+HE2308		
UKPA208+HS2308	13/8											UK208+HS2308		
UKPA209+H2309	40	54,2	120	90	60	25	108	49,2	M14	32395	20235	UK209+H2309	PA209	2,29
UKPA209+HA2309	17/16	29/64	423/32	335/64	223/64	63/64	4¼	1,9370	½			UK209+HA2309		
UKPA209+HE2309	1½											UK209+HE2309		
UKPA209+HS2309	15/8											UK209+HS2309		
UKPA210+H2310	45	57,2	130	94	64	25	116	51,6	M16	33345	22135	UK210+H2310	PA210	2,89
UKPA210+HS2310	15/8	2½	51/8	345/64	233/64	63/64	49/16	2,0315	5/8			UK210+HS2310		
UKPA210+HA2310	111/16											UK210+HA2310		
UKPA210+HE2310	1¾											UK210+HE2310		

Manguitos HA; HE; HS con rosca en pulgadas
Inch dimension adapter sleeves HA; HE; HS

UCFA2 Serie normal - Standard duty

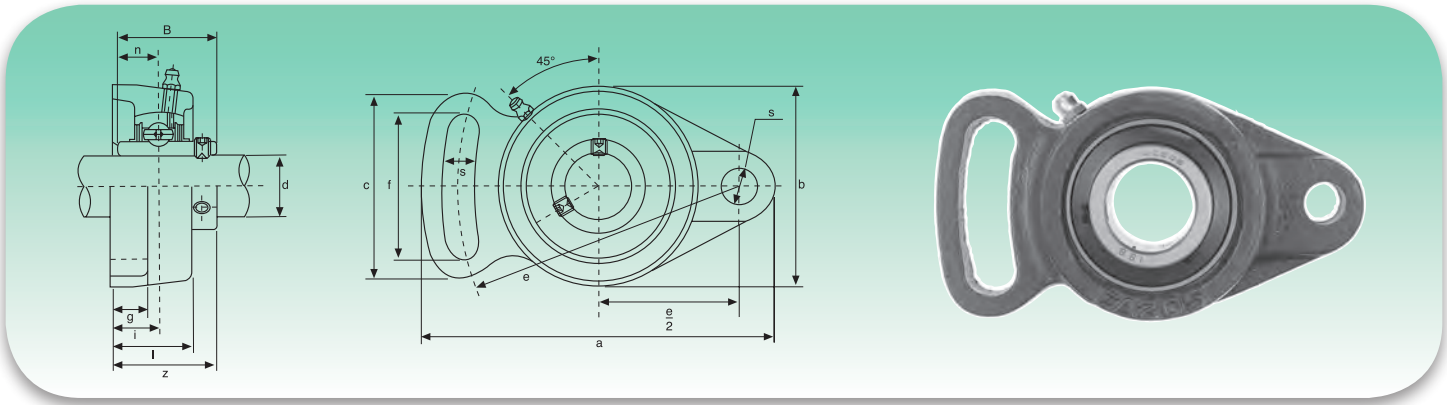

Tipo Type	Dimensiones - Dimensions													Bul. fij. Bolt Size	Coeficientes de carga (N) Load ratings (N)		Rodamiento Bearing	Soporte Housing	Peso Weight	
	d	a	e	i	g	l	s	b	z	f	c	B	n		Dinámica C Dynamic C	Estática C ₀ Static C ₀				kg
	mm/inch														mm/inch					
UCFA201	12	98	78	15	12	25,5	10	60	33,3	40	50	31	12,7	M8	12160	6318	UC201 UC201-8	FA204	0,50	
UCFA201-8	¾	355/64	35/64	19/32	15/32	1	25/64	23/8	15/16	137/64	131/32	1,2205	0,500	5/16					0,49	
UCFA202	15	98	78	15	12	25,5	10	60	33,3	40	50	31	12,7	M8	12160	6318	UC202 UC202-9 UC202-10	FA204	0,49	
UCFA202-9	9/16	355/64	35/64	19/32	15/32	1	25/64	23/8	15/16	137/64	131/32	1,2205	0,500	5/16					0,49	
UCFA202-10	5/8																			0,49
UCFA203	17	98	78	15	12	25,5	10	60	33,3	40	50	31	12,7	M8	12160	6318	UC203 UC203-11	FA204	0,48	
UCFA203-11	11/16	355/64	35/64	19/32	15/32	1	25/64	23/8	15/16	137/64	131/32	1,2205	0,500	5/16					0,47	
UCFA204	20	98	78	15	12	25,5	10	60	33,3	40	50	31	12,7	M8	12160	6318	UC204 UC204-12	FA204	0,46	
UCFA204-12	¾	355/64	35/64	19/32	15/32	1	25/64	23/8	15/16	137/64	131/32	1,2205	0,500	5/16					0,46	
UCFA205	25	124	98	16	14	27	13	70	35,8	51	65	34,1	14,3	M10	13300	7457	UC205 UC205-13 UC205-14 UC205-15 UC205-16	FA205	0,66	
UCFA205-13	13/16	47/8	355/64	5/8	35/64	11/6	33/64	2¾	113/32	21/64	29/16	1,3425	0,563	3/8					0,70	
UCFA205-14	7/8																			0,69
UCFA205-15	15/16																			0,67
UCFA205-16	1																			0,66
UCFA206	30	141	115	18	14	31	13	83	40,2	58	72	38,1	15,9	M10	18525	10735	UC206 UC206-17 UC206-18 UC206-19 UC206-20	FA206	0,93	
UCFA206-17	11/16	535/64	417/32	45/64	35/64	17/32	33/64	317/64	119/32	29/32	227/32	1,5000	0,626	3/8					0,96	
UCFA206-18	11/8																			0,95
UCFA206-19	13/16																			0,93
UCFA206-20	1¼																			0,92
UCFA207	35	155	128	19	16	34	15	96	44,4	66	82	42,9	17,5	M12	24415	14630	UC207 UC207-20 UC207-21 UC207-22 UC207-23	FA207	1,46	
UCFA207-20	1¼	67/64	53/64	¾	5/8	111/32	19/32	325/32	1¾	219/32	315/64	1,6890	0,689	7/16					1,52	
UCFA207-21	15/16																			1,49
UCFA207-22	13/8																			1,46
UCFA207-23	17/16																			1,43
UCFA208	40	171	142	21	16	38	15	105	51,2	71	87	49,2	19	M12	27645	16910	UC208 UC208-24 UC208-25	FA208	1,78	
UCFA208-24	1½	47/64	519/32	53/64	5/8	1½	19/32	49/64	21/64	251/64	327/64	1,9370	0,748	7/16					1,82	
UCFA208-25	19/16																			1,79
UCFA209	45	179	146	22	18	40	17	111	52,2	72	90	49,2	19	M14	32395	20235	UC209 UC209-26 UC209-27 UC209-28	FA209	2,03	
UCFA209-26	15/8	73/64	5¾	55/64	45/64	137/64	43/64	43/8	21/16	253/64	335/64	1,9370	0,748	½					2,13	
UCFA209-27	111/16																			2,09
UCFA209-28	1¾																			2,05
UCFA210	50	189	155	22	18	40	17	116	54,6	76	94	51,6	19	M14	33345	22135	UC210 UC210-29 UC210-30 UC210-31 UC210-32	FA210	2,23	
UCFA210-29	113/16	77/16	67/64	55/64	45/64	137/64	43/64	49/16	25/32	3	345/64	2,0315	0,748	½					2,35	
UCFA210-30	17/8																			2,30
UCFA210-31	115/16																			2,25
UCFA210-32	2	2,21																		
UCFA211	55	216	182	25	20	44	17	133	58,4	86	104	55,6	22,2	M14	41230	27930	UC211 UC211-32 UC211-33 UC211-34 UC211-35	FA211	3,2	
UCFA211-32	2	8½	711/64	63/64	25/32	147/64	43/64	551/64	25/16	325/64	43/32	2,1890	0,874	½					4,5	
UCFA211-33	21/16																			4,20
UCFA211-34	21/8																			4,10
UCFA211-35	23/16																			4,00
UCFA212	60	240	202	29	20	48	19	140	68,7	100	118	65,1	25,4	M16	49780	34390	UC212 UC212-36 UC212-37 UC212-38 UC212-39	FA212	-	
UCFA212-36	2¼	929/64	761/64	19/64	25/32	17/8	¾	5½	223/32	315/16	441/64	2,5630	1,000	5/8					-	
UCFA212-37	25/16																			-
UCFA212-38	23/8																			-
UCFA212-39	27/16																			-
UCFA213	65	250	210	30	20	50	19	155	69,7	102	122	65,1	25,4	M16	54340	38095	UC213 UC213-40 UC213-41	FA213	-	
UCFA213-40	2½	927/32	817/64	13/16	25/32	131/32	¾	63/32	2¾	41/64	451/64	2,5630	1,000	5/8					-	
UCFA213-41	29/16																			-

Disponibile in acciaio inox. Soporte: AISI 304 - Rodamiento: AISI 440C - Available stainless steel Housing: AISI 304 - Bearing: AISI 440C
 Disponibile a petizione con rodamento SA (SAFA) - Available under request with SA bearing (SAFA)

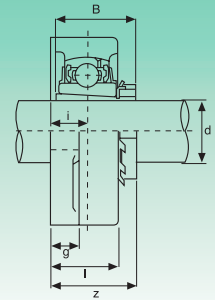
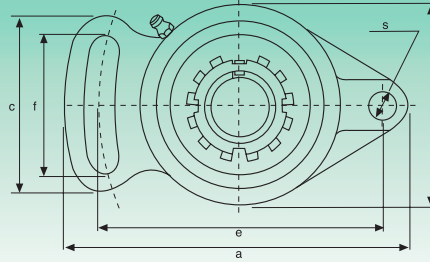
UKFA2 Serie normal - Standard duty

Tipo Type	Dimensiones - Dimensions												Bul. fij. Bolt Size	Coeficientes de carga (N) Load ratings (N)		Rodamiento Bearing	Soporte Housing	Peso Weight	
	d	a	e	i	g	l	s	b	z	f	c	B		Dinámica C Dynamic C	Estática C ₀ Static C ₀				kg
	mm/inch													mm/inch					
UKFA205+H2305	20	124	98	16	14	27	13	70	35,8	51	65	34,1	M10	13300	7457	UK205+H2305	FA205	0,71	
UKPA205+HE2305	¾	47/8	355/64	5/8	35/64	11/16	33/64	2¾	113/32	21/64	29/16	1,3425	3/8			UK205+HE2305			
UKFA206+H2306	25	141	115	18	14	31	13	83	40,2	58	72	38,1	M10	18525	10735	UK206+H2306	FA206	1,04	
UKPA206+HS2306	7/8	535/64	417/32	45/64	35/64	17/32	33/64	317/64	119/32	29/32	227/32	1,5000	3/8			UK206+HS2306			
UKPA206+HE2306	1															UK206+HE2306			
UKFA207+H2307	30	155	128	19	16	34	15	96	44,4	66	82	42,9	M12	24415	14630	UK207+H2307	FA207	1,5	
UKPA207+HS2307	11/8	67/64	53/64	¾	5/8	111/32	19/32	325/32	1¾	219/32	315/64	1,6890	7/16			UK207+HS2307			
UKFA208+H2308	35	171	142	21	16	38	15	105	51,2	71	87	49,2	M12	27645	16910	UK208+H2308	FA208	1,9	
UKPA208+HE2308	1¼	47/64	519/32	53/64	5/8	1½	19/32	49/64	21/64	251/64	327/64	1,9370	7/16			UK208+HE2308			
UKPA208+HS2308	13/8															UK208+HS2308			
UKFA209+H2309	40	179	146	22	18	40	17	111	52,2	72	90	49,2	M14	32395	20235	UK209+H2309	FA209	1,8	
UKPA209+HA2309	17/16	73/64	5¾	55/64	45/64	137/64	43/64	43/8	21/16	253/64	335/64	1,9370	½			UK209+HA2309			
UKPA209+HE2309	1½															UK209+HE2309			
UKPA209+HS2309	15/8															UK209+HS2309			
UKFA210+H2310	45	189	155	22	18	40	17	116	54,6	76	94	51,6	M14	33345	22135	UK210+H2310	FA210	2,1	
UKPA210+HS2310	15/8	111/16	71/16	67/64	55/64	45/64	137/64	43/64	49/16	25/32	3	345/64	2,0315			½			UK210+HS2310
UKPA210+HA2310	111/16																		UK210+HA2310
UKPA210+HE2310	1¾																		UK210+HE2310

Manguitos HA; HE; HS con rosca en pulgadas
Inch dimension adapter sleeves HA; HE; HS

UCFB2 Serie normal - Standard duty

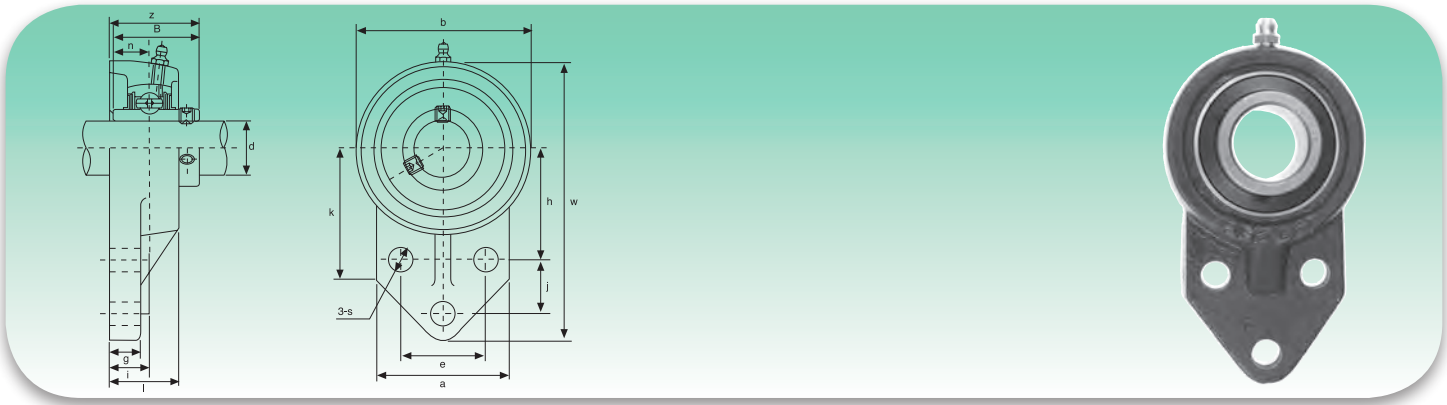

Tipo Type	Dimensiones - Dimensions														Bul. fj. Bolt Size	Coeficientes de carga (N) Load ratings (N)		Rodamiento Bearing	Soporte Housing	Peso Weight	
	d	w	b	k	a	l	s	g	h	j	e	i	z	B		n	Dinámica C Dynamic C				Estática C ₀ Static C ₀
	mm/inch															mm/inch					
UCFB201	12	110	62	52	52	25,5	10	13	42	27	32	15	33,3	31	12,7	M8	12160	6318	UC201	FB204	0,58
UCFB201-8	3/4	411/32	27/16	21/16	21/16	1	25/64	1/2	121/32	11/16	117/64	19/32	15/16	1,2205	0,500	5/16			UC201-8		0,57
UCFB202	15	110	62	52	52	25,5	10	13	42	27	32	15	33,3	31	12,7	M8	12160	6318	UC202	FB204	0,57
UCFB202-9	9/16	411/32	27/16	21/16	21/16	1	25/64	1/2	121/32	11/16	117/64	19/32	15/16	1,2205	0,500	5/16			UC202-9		0,57
UCFB202-10	5/8	411/32	27/16	21/16	21/16	1	25/64	1/2	121/32	11/16	117/64	19/32	15/16	1,2205	0,500	5/16			UC202-10		0,57
UCFB203	17	110	62	52	52	25,5	10	13	42	27	32	15	33,3	31	12,7	M8	12160	6318	UC203	FB204	0,56
UCFB203-11	11/16	411/32	27/16	21/16	21/16	1	25/64	1/2	121/32	11/16	117/64	19/32	15/16	1,2205	0,500	5/16			UC203-11		0,55
UCFB204	20	110	62	52	52	25,5	10	13	42	27	32	15	33,3	31	12,7	M8	12160	6318	UC204	FB204	0,54
UCFB204-12	3/4	411/32	27/16	21/16	21/16	1	25/64	1/2	121/32	11/16	117/64	19/32	15/16	1,2205	0,500	5/16			UC204-12		0,54
UCFB205	25	116	68	52	56	27	10	13	45	27	34	16	35,8	34,1	14,3	M8	13300	7457	UC205	FB205	0,79
UCFB205-13	13/16	49/16	211/16	21/16	27/32	11/16	25/64	1/2	149/64	11/16	111/32	5/8	113/32	1,3425	0,563	5/16			UC205-13		0,83
UCFB205-14	7/8	49/16	211/16	21/16	27/32	11/16	25/64	1/2	149/64	11/16	111/32	5/8	113/32	1,3425	0,563	5/16			UC205-14		0,82
UCFB205-15	15/16	49/16	211/16	21/16	27/32	11/16	25/64	1/2	149/64	11/16	111/32	5/8	113/32	1,3425	0,563	5/16			UC205-15		0,80
UCFB205-16	1	49/16	211/16	21/16	27/32	11/16	25/64	1/2	149/64	11/16	111/32	5/8	113/32	1,3425	0,563	5/16			UC205-16		0,79
UCFB206	30	130	78	55	65	31	10	13	50	29	40	18	40,2	38,1	15,9	M8	18525	10735	UC206	FB206	0,95
UCFB206-17	11/16	51/8	31/16	25/32	29/16	17/32	25/64	1/2	131/32	19/64	137/64	45/64	119/32	1,5000	0,626	5/16			UC206-17		0,98
UCFB206-18	11/8	51/8	31/16	25/32	29/16	17/32	25/64	1/2	131/32	19/64	137/64	45/64	119/32	1,5000	0,626	5/16			UC206-18		0,97
UCFB206-19	13/16	51/8	31/16	25/32	29/16	17/32	25/64	1/2	131/32	19/64	137/64	45/64	119/32	1,5000	0,626	5/16			UC206-19		0,95
UCFB206-20	1 1/4	51/8	31/16	25/32	29/16	17/32	25/64	1/2	131/32	19/64	137/64	45/64	119/32	1,5000	0,626	5/16			UC206-20		0,94
UCFB207	35	144	90	62	70	34	10	15	55	32	46	19	44,4	42,9	17,5	M8	24415	14630	UC207	FB207	1,29
UCFB207-20	1 1/4	521/32	335/64	27/16	2 3/4	111/32	25/64	19/32	211/64	117/64	113/16	3/4	1 3/4	1,6890	0,689	5/16			UC207-20		1,35
UCFB207-21	15/16	521/32	335/64	27/16	2 3/4	111/32	25/64	19/32	211/64	117/64	113/16	3/4	1 3/4	1,6890	0,689	5/16			UC207-21		1,32
UCFB207-22	13/8	521/32	335/64	27/16	2 3/4	111/32	25/64	19/32	211/64	117/64	113/16	3/4	1 3/4	1,6890	0,689	5/16			UC207-22		1,29
UCFB207-23	17/16	521/32	335/64	27/16	2 3/4	111/32	25/64	19/32	211/64	117/64	113/16	3/4	1 3/4	1,6890	0,689	5/16			UC207-23		1,26
UCFB208	40	164	100	72	78	36	12	16	60	41	50	21	51,2	49,2	19	M10	27645	16910	UC208	FB208	1,78
UCFB208-24	1 1/2	615/32	315/16	227/32	31/16	113/32	15/32	5/8	223/64	139/64	131/32	53/64	21/64	1,9370	0,748	3/8			UC208-24		1,82
UCFB208-25	19/16	615/32	315/16	227/32	31/16	113/32	15/32	5/8	223/64	139/64	131/32	53/64	21/64	1,9370	0,748	3/8			UC208-25		1,79
UCFB209	45	174	106	76	80	38	12	18	65	43	54	22	52,2	49,2	19	M10	32395	20235	UC209	FB209	1,91
UCFB209-26	15/8	627/32	43/16	3	35/32	1 1/2	15/32	23/32	29/16	111/16	21/8	55/64	21/16	1,9370	0,748	3/8			UC209-26		2,01
UCFB209-27	111/16	627/32	43/16	3	35/32	1 1/2	15/32	23/32	29/16	111/16	21/8	55/64	21/16	1,9370	0,748	3/8			UC209-27		1,97
UCFB209-28	1 3/4	627/32	43/16	3	35/32	1 1/2	15/32	23/32	29/16	111/16	21/8	55/64	21/16	1,9370	0,748	3/8			UC209-28		1,93
UCFB210	50	184	112	82	86	40	12	18	68	46	58	22	54,6	51,6	19	M10	33345	22135	UC210	FB210	2,36
UCFB210-29	113/16	71/14	413/32	37/32	33/8	137/64	15/32	23/32	243/64	113/16	29/32	55/64	25/32	2,0315	0,748	3/8			UC210-29		2,48
UCFB210-30	17/8	71/14	413/32	37/32	33/8	137/64	15/32	23/32	243/64	113/16	29/32	55/64	25/32	2,0315	0,748	3/8			UC210-30		2,43
UCFB210-31	115/16	71/14	413/32	37/32	33/8	137/64	15/32	23/32	243/64	113/16	29/32	55/64	25/32	2,0315	0,748	3/8			UC210-31		2,38
UCFA210-32	2	71/14	413/32	37/32	33/8	137/64	15/32	23/32	243/64	113/16	29/32	55/64	25/32	2,0315	0,748	3/8			UC210-32		2,34
UCFB211	55	207	130	86	90	43	14	18	78	50	62	25	58,4	55,6	22,2	M12	41230	27930	UC211	FB211	3,15
UCFB211-32	2	85/32	51/8	325/64	335/64	111/16	35/64	45/64	35/64	131/32	27/16	63/64	25/16	2,1890	0,874	7/16			UC211-32		3,31
UCFB211-33	21/16	85/32	51/8	325/64	335/64	111/16	35/64	45/64	35/64	131/32	27/16	63/64	25/16	2,1890	0,874	7/16			UC211-33		3,25
UCFB211-34	21/8	85/32	51/8	325/64	335/64	111/16	35/64	45/64	35/64	131/32	27/16	63/64	25/16	2,1890	0,874	7/16			UC211-34		3,20
UCFB211-35	23/16	85/32	51/8	325/64	335/64	111/16	35/64	45/64	35/64	131/32	27/16	63/64	25/16	2,1890	0,874	7/16			UC211-35		3,14
UCFB212	60	223	140	90	94	48	14	18	84	55	66	29	68,7	65,1	25,4	M12	49780	34390	UC212	FB212	3,99
UCFB212-36	2 1/4	825/32	5 1/2	335/64	345/64	17/8	35/64	45/64	35/16	211/64	219/32	19/64	223/32	2,5630	1,000	7/16			UC212-36		4,12
UCFB212-37	25/16	825/32	5 1/2	335/64	345/64	17/8	35/64	45/64	35/16	211/64	219/32	19/64	223/32	2,5630	1,000	7/16			UC212-37		4,04
UCFB212-38	23/8	825/32	5 1/2	335/64	345/64	17/8	35/64	45/64	35/16	211/64	219/32	19/64	223/32	2,5630	1,000	7/16			UC212-38		3,97
UCFB212-39	27/16	825/32	5 1/2	335/64	345/64	17/8	35/64	45/64	35/16	211/64	219/32	19/64	223/32	2,5630	1,000	7/16			UC212-39		3,90
UCFB213	65	244	155	94	100	50	14	20	92	60	70	30	69,7	65,1	25,4	M12	54340	38095	UC213	FB213	-
UCFB213-40	2 1/2	939/64	67/64	345/64	315/16	131/32	35/64	25/32	35/8	223/64	2 3/4	13/16	2 3/4	2,5630	1,000	7/16			UC213-40		-
UCFB213-41	29/16	939/64	67/64	345/64	315/16	131/32	35/64	25/32	35/8	223/64	2 3/4	13/16	2 3/4	2,5630	1,000	7/16			UC213-41		-

Disponibile in acciaio inox. Soporte: AISI 304 - Rodamiento: AISI 440C - Available stainless steel Housing: AISI 304 - Bearing: AISI 440C
 Disponibile a petizione con rodamento SA (SAFB) - Available under request with SA bearing (SAFB)

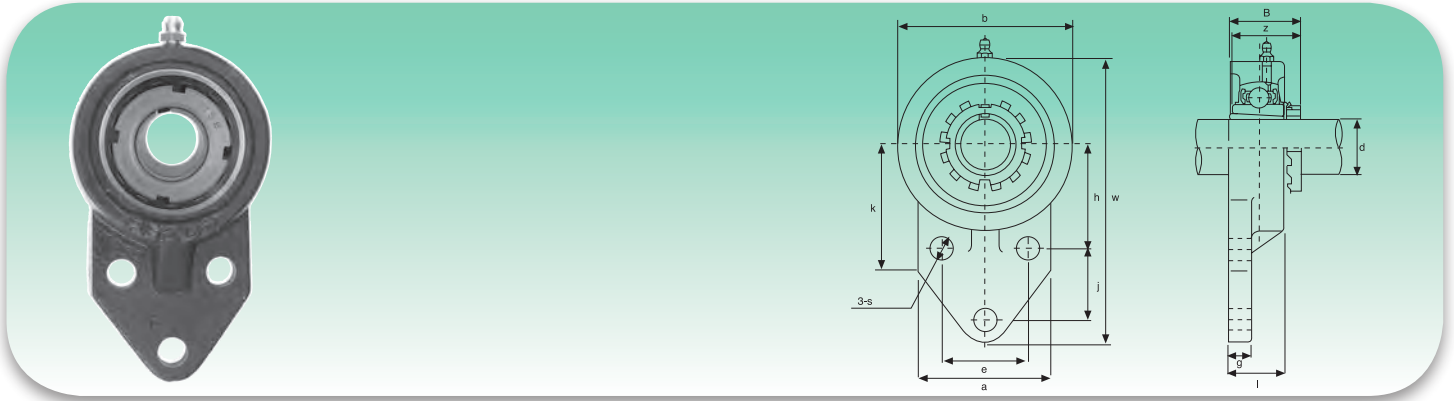
UKFB2 Serie normal - Standard duty

Tipo Type	Dimensiones - Dimensions														Bul. fij. Bolt Size	Coeficientes de carga (N) Load ratings (N)		Rodamiento Bearing	Soporte Housing	Peso Weight kg	
	d	w	b	k	a	l	s	g	h	j	e	i	z	B		Dinámica C Dynamic C	Estática C _o Static C _o				
	mm/inch															mm/inch					
UKFB205+H2305	20	116	68	52	56	27	10	13	45	27	34	16	35,8	34,1	M8	13300	7457	UK205+H2305	FB205	0,72	
UKPA205+HE2305	¾	49/16	211/16	21/16	27/32	11/16	25/64	½	149/64	11/16	111/32	5/8	113/32	1,3425	5/16			UK205+HE2305			
UKFB206+H2306	25	130	78	55	65	31	10	13	50	29	40	18	40,2	38,1	M8	18525	10735	UK206+H2306	FB206	0,96	
UKPA206+HS2306	7/8	51/8	31/16	25/32	29/16	17/32	25/64	½	131/32	19/64	137/64	45/64	119/32	1,5000	5/16			UK206+HS2306			
UKPA206+HE2306	1																	UK206+HE2306			
UKFB207+H2307	30	144	90	62	70	34	10	15	55	32	46	19	44,4	42,9	M8	24415	14630	UK207+H2307	FB207	1,33	
UKPA207+HS2307	11/8	521/32	335/64	27/16	2¾	111/32	25/64	19/32	211/64	117/64	113/16	¾	1¾	1,6890	5/16			UK207+HS2307			
UKFB208+H2308	35	164	100	72	78	36	12	16	60	41	50	21	51,2	49,2	M10	27645	16910	UK208+H2308	FB208	1,82	
UKPA208+HE2308	1¼	615/32	315/16	227/32	31/16	113/32	15/32	5/8	223/32	139/64	131/32	53/64	21/64	1,9370	3/8			UK208+HE2308			
UKPA208+HS2308	13/8																	UK208+HS2308			
UKFB209+H2309	40	174	106	76	80	38	12	18	65	43	54	22	52,2	49,2	M10	32395	20235	UK209+H2309	FB209	2,09	
UKPA209+HA2309	17/16	627/32	43/16	3	35/32	1½	15/32	23/32	29/16	111/16	21/8	55/64	21/16	1,9370	3/8			UK209+HA2309			
UKPA209+HE2309	1½																	UK209+HE2309			
UKPA209+HS2309	15/8																	UK209+HS2309			
UKFB210+H2310	45	184	112	82	86	40	12	18	68	46	58	22	54,6	51,6	M10	33345	22135	UK210+H2310	FB210	2,39	
UKPA210+HS2310	15/8	111/16	7¼	413/32	37/32	33/8	137/64	15/32	23/32	243/64	113/16	29/32	55/64	25/32	2,0315			3/8			UK210+HS2310
UKPA210+HA2310	111/16																				UK210+HA2310
UKPA210+HE2310	1¾																				UK210+HE2310

Manguitos HA; HE; HS con rosca en pulgadas
Inch dimension adapter sleeves HA; HE; HS

UCECH2 Serie normal - Standard duty

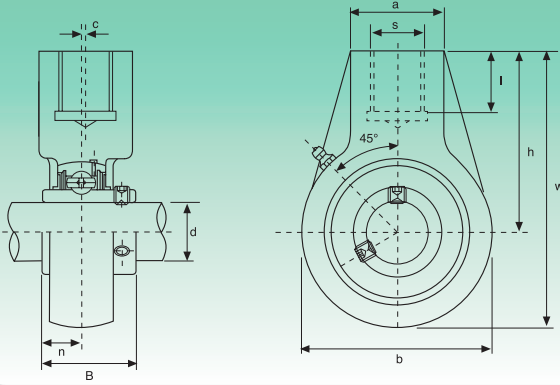

Tipo Type	Dimensiones - Dimensions										Coeficientes de carga (N) Load ratings (N)		Rodamiento Bearing	Soporte Housing	Peso Weight
	d	h	w	b	c	a	l	B	n	S	Dinámica C Dynamic C	Estática C _o Static C _o			
	mm/inch														
UCECH201	12	64	96	64	0	40	19	31	12,7	G $\frac{3}{4}$	12160	6318	UC201	ECH204	0,73
UCECH201-8	$\frac{3}{4}$	233/64	325/32	233/64	0	137/64	$\frac{3}{4}$	1,2205	0,500				UC201-8		0,72
UCECH202	15	64	96	64	0	40	19	31	12,7	G $\frac{3}{4}$	12160	6318	UC202	ECH204	0,72
UCECH202-9	9/16	233/64	325/32	233/64	0	137/64	$\frac{3}{4}$	1,2205	0,500				UC202-9		0,72
UCECH202-10	5/8												UC202-10		0,72
UCECH203	17	64	96	64	0	40	19	31	12,7	G $\frac{3}{4}$	12160	6318	UC203	ECH204	0,71
UCECH203-11	11/16	233/64	325/32	233/64	0	137/64	$\frac{3}{4}$	1,2205	0,500				UC203-11		0,70
UCECH204	20	64	96	64	0	40	19	31	12,7	G $\frac{3}{4}$	12160	6318	UC204	ECH204	0,69
UCECH204-12	$\frac{3}{4}$	233/64	325/32	233/64	0	137/64	$\frac{3}{4}$	1,2205	0,500				UC204-12		0,69
UCECH205	25	64	103	78	0	40	19	34,1	14,3				UC205		0,83
UCECH205-13	13/16												UC205-13		0,87
UCECH205-14	7/8	233/64	41/16	35/64	0	137/64	$\frac{3}{4}$	1,3425	0,563	G $\frac{3}{4}$	13300	7457	UC205-14	ECH205	0,86
UCECH205-15	15/16												UC205-15		0,84
UCECH205-16	1												UC205-16		0,83
UCECH206	30	64	103	78	0	40	19	38,1	15,9				UC206		0,83
UCECH206-17	11/16												UC206-17		0,86
UCECH206-18	11/8	233/64	41/16	35/64	0	137/64	$\frac{3}{4}$	1,5000	0,626	G $\frac{3}{4}$	18525	10735	UC206-18	ECH206	0,85
UCECH206-19	13/16												UC206-19		0,83
UCECH206-20	1 $\frac{1}{4}$												UC206-20		0,82
UCECH207	35	70	116	92	0	40	19	42,9	17,5				UC207		1,16
UCECH207-20	1 $\frac{1}{4}$												UC207-20		1,22
UCECH207-21	15/16	2 $\frac{3}{4}$	49/16	35/8	0	137/64	$\frac{3}{4}$	1,6890	0,689	G $\frac{3}{4}$	24415	14630	UC207-21	ECH207	1,19
UCECH207-22	13/8												UC207-22		1,16
UCECH207-23	17/16												UC207-23		1,13
UCECH208	40	73	121	96	2	40	19	49,2	19	G $\frac{3}{4}$	27645	16910	UC208	ECH208	1,32
UCECH208-24	1 $\frac{1}{2}$	27/8	449/64	325/32	5/64	137/64	$\frac{3}{4}$	1,9370	0,748				UC208-24		1,36
UCECH208-25	19/16												UC208-25		1,33
UCECH209	45	82	136	108	5	48	21	49,2	19				UC209		1,92
UCECH209-26	15/8												UC209-26	ECH209	2,02
UCECH209-27	111/16	315/64	523/64	4 $\frac{1}{4}$	13/64	157/64	53/64	1,9370	0,748	G1	32395	20235	UC209-27		1,98
UCECH209-28	1 $\frac{3}{4}$												UC209-28		1,94
UCECH210	50	83	142	118	5	48	21	51,6	19				UC210		1,90
UCECH210-29	113/16												UC210-29	ECH210	2,02
UCECH210-30	17/8	317/64	519/32	441/64	13/64	157/64	53/64	2,0315	0,748	G1	33345	22135	UC210-30		1,97
UCECH210-31	115/16												UC210-31		1,92
UCECH210-32	2												UC210-32		1,88
UCECH211	55	87	150	126	7	60	25	55,6	22,2				UC211		2,61
UCECH211-32	2												UC211-32	ECH211	2,76
UCECH211-33	21/16	327/64	529/32	461/64	9/32	223/64	63/64	2,1890	0,874	G1 $\frac{1}{4}$	41230	27930	UC211-33		2,70
UCECH211-34	21/8												UC211-34		2,65
UCECH211-35	23/16												UC211-35		2,59
UCECH212	60	102	173	142	9	60	28	65,1	25,4				UC212		3,54
UCECH212-36	2 $\frac{1}{4}$												UC212-36	ECH212	3,67
UCECH212-37	25/16	41/64	613/16	519/32	23/64	223/64	17/64	2,5630	1,000	G1 $\frac{1}{4}$	49780	34390	UC212-37		3,59
UCECH212-38	23/8												UC212-38		3,52
UCECH212-39	27/16												UC212-39		3,45
UCECH213	65	117	200	166	9,5	70	32	65,1	25,4				UC213		5,80
UCECH213-40	2 $\frac{1}{2}$	439/64	77/8	617/32	3/8	2 $\frac{3}{4}$	117/64	2,5630	1,000	G1 $\frac{1}{2}$	54340	38095	UC213-40	ECH213	5,89
UCECH213-41	29/16												UC213-41		5,80
UCECH214	70	117	200	166	9,5	70	32	74,6	30,2				UC214		5,67
UCECH214-42	25/8												UC214-42	ECH214	5,67
UCECH214-43	211/16	439/64	77/8	617/32	3/8	2 $\frac{3}{4}$	117/64	2,9370	1,189	G1 $\frac{1}{2}$	59090	41895	UC214-43		5,67
UCECH214-44	2 $\frac{3}{4}$												UC214-44		5,67
UCECH215	75	117	200	166	9,5	70	32	77,8	33,3				UC215		5,58
UCECH215-45	213/16												UC215-45	ECH215	5,58
UCECH215-46	27/8	439/64	731/32	617/32	3/8	2 $\frac{3}{4}$	117/64	3,0630	1,311	G1 $\frac{1}{2}$	64030	45885	UC215-46		5,58
UCECH215-47	215/16												UC215-47		5,58
UCECH215-48	3												UC215-48		5,58

Disponibile en acero inox. Soporte: AISI 304 - Rodamiento: AISI 440C - Available stainless steel Housing: AISI 304 - Bearing: AISI 440C
 Disponible a petición con rodamiento SA (SAECH) - Available under request with SA bearing (SAECH)

S - Bajo demanda disponibles con rosca métrica, en pulgadas y gas
 S - Under request available with metric, inches and gas thread

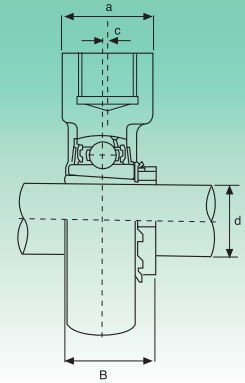
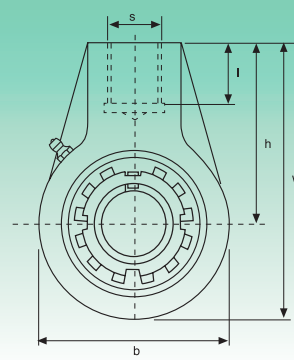
UKECH2 Serie normal - Standard duty

Tipo Type	Dimensiones - Dimensions									Coeficientes de carga (N) Load ratings (N)		Rodamiento Bearing	Soporte Housing	Peso Weight kg		
	d	h	w	b	c	a	l	B	S	Dinámica C Dynamic C	Estática C ₀ Static C ₀					
	mm/inch															
UKECH205+H2305	20	64	103	78	0	40	19	34,1		G $\frac{3}{4}$	13300	7457	UK205+H2305	ECH205	0,9	
UKECH205+HE2305	$\frac{3}{4}$	233/64	41/16	35/64	0	137/64	$\frac{3}{4}$	1,3425								UK205+HE2305
UKECH206+H2306	25	64	103	78	0	40	19	38,1		G $\frac{3}{4}$	18525	10735	UK206+H2306	ECH206	0,9	
UKECH206+HS2306	$\frac{7}{8}$	233/64	41/16	35/64	0	137/64	$\frac{3}{4}$	1,5000								UK206+HS2306
UKECH206+HE2306	1	233/64	41/16	35/64	0	137/64	$\frac{3}{4}$	1,5000								UK206+HE2306
UKECH207+H2307	30	70	116	92	0	40	19	42,9		G $\frac{3}{4}$	24415	14630	UK207+H2307	ECH207	1,23	
UKECH207+HS2307	$\frac{11}{8}$	$2\frac{3}{4}$	49/16	35/8	0	137/64	$\frac{3}{4}$	1,6890								UK207+HS2307
UKECH208+H2308	35	73	121	96	2	40	19	49,2		G $\frac{3}{4}$	27645	16910	UK208+H2308	ECH208	1,32	
UKECH208+HE2308	$1\frac{1}{4}$	27/8	449/64	325/32	5/64	137/64	$\frac{3}{4}$	1,9370								UK208+HE2308
UKECH208+HS2308	$\frac{13}{8}$	27/8	449/64	325/32	5/64	137/64	$\frac{3}{4}$	1,9370								UK208+HS2308
UKECH209+H2309	40	82	136	108	5	48	21	49,2		G1	32395	20235	UK209+H2309	ECH209	1,79	
UKECH209+HA2309	$\frac{17}{16}$	315/64	523/64	4 $\frac{1}{4}$	13/64	157/64	53/64	1,9370								UK209+HA2309
UKECH209+HE2309	$1\frac{1}{2}$	315/64	523/64	4 $\frac{1}{4}$	13/64	157/64	53/64	1,9370								UK209+HE2309
UKECH209+HS2309	$\frac{15}{8}$	315/64	523/64	4 $\frac{1}{4}$	13/64	157/64	53/64	1,9370								UK209+HS2309
UKECH210+H2310	45	83	142	118	5	48	21	51,6		G1	33345	22135	UK210+H2310	ECH210	2,19	
UKECH210+HS2310	$\frac{15}{8}$	317/64	519/32	441/64	13/64	157/64	53/64	2,0315								UK210+HS2310
UKECH210+HA2310	$\frac{111}{16}$	317/64	519/32	441/64	13/64	157/64	53/64	2,0315								UK210+HA2310
UKECH210+HE2310	$1\frac{3}{4}$	317/64	519/32	441/64	13/64	157/64	53/64	2,0315								UK210+HE2310
UKECH211+H2311	50	87	150	126	7	60	25	55,6		G1 $\frac{1}{4}$	41230	27930	UK211+H2311	ECH211	2,84	
UKECH211+HS2311	$\frac{17}{8}$	327/64	529/32	461/64	9/32	223/64	63/64	2,1890								UK211+HS2311
UKECH211+HA2311	$\frac{115}{16}$	327/64	529/32	461/64	9/32	223/64	63/64	2,1890								UK211+HA2311
UKECH211+HE2311	2	327/64	529/32	461/64	9/32	223/64	63/64	2,1890								UK211+HE2311
UKECH212+H2312	55	102	173	142	9	60	28	65,1		G1 $\frac{1}{4}$	49780	34390	UK212+H2312	ECH212	3,81	
UKECH212+HS2312	$\frac{21}{8}$	41/64	613/16	519/32	23/64	223/64	17/64	2,5630								UK212+HS2312

Manguitos HA; HE; HS con rosca en pulgadas
Inch dimension adapter sleeves HA; HE; HS

S - Bajo demanda disponibles con rosca métrica, en pulgadas y gas
S - Under request available with metric, inches and gas thread

UP Serie ligera - Light duty

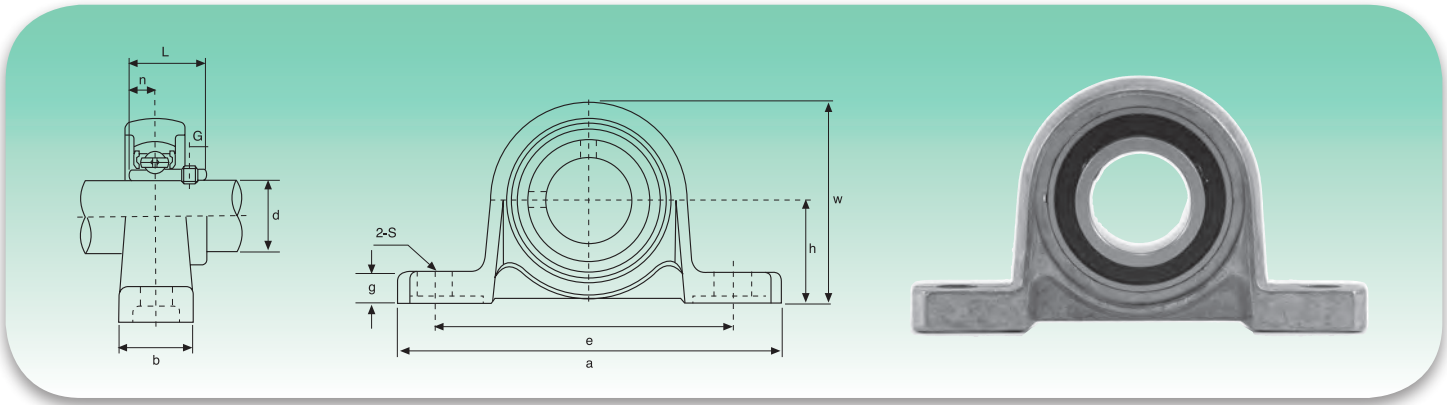

Tipo Type	Dimensiones - Dimensions											Bul. fj. Bolt Size	Coeficientes de carga (N) Load ratings (N)		Rodamiento Bearing	Soporte Housing	Peso Weight kg
	d	h	a	e	b	s	g	w	L	n	G		Dinámica C Dynamic C	Estática C ₀ Static C ₀			
	mm/inch																
UP000	10	18	67	53	16	7	6	35	14	4	4	M6	4322	1852	U000	LP000	0,077
UP001	12	19	71	56	16	7	6	38	17,5	4	4	M6	4845	2280	U001	LP001	0,091
UP002	15	22	80	63	16	6	7	43	18,5	4,5	4	M6	5320	2707	U002	LP002	0,125
UP003	17	24	85	67	18	6	7	47	20,5	5	4	M6	5700	3087	U003	LP003	0,156
UP004	20	28	100	80	20	10	9	55	24,5	6	4,5	M8	8930	4797	U004	LP004	0,230
UP005	25	32	112	90	20	10	10	62	25,5	6	5	M8	9595	5557	U005	LP005	0,294
UP006	30	36	132	106	26	13	11	70	26,5	6,5	5	M10	12540	7837	U006	LP006	0,454
UP007	35	40	150	118	26	13	13	80	29,5	7	6	M10	14750	9750	U007	LP007	0,593

Disponibile bajo demanda en acero inox. soporte: AISI 304 - Rodamiento: AISI 440C - Available under request stainless steel housing: AISI 304 - Bearing: AISI 440C
 Bajo demanda suministrables también con anillo excéntrico de fijación - Under request available with eccentric collar locking

SOPORTES DE BRIDA OVALADA DE ALUMINIO - ALUMINIUM OVAL BEARING UNITS

UFL Serie ligera - Light duty

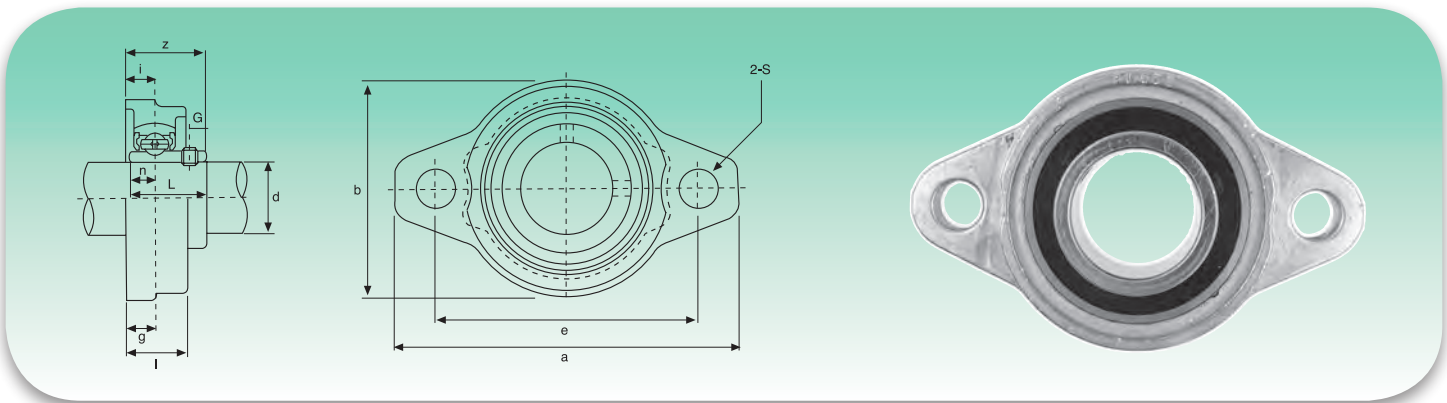

Tipo Type	Dimensiones - Dimensions											Bul. fj. Bolt Size	Coeficientes de carga (N) Load ratings (N)		Rodamiento Bearing	Soporte Housing	Peso Weight kg	
	d	a	e	i	g	l	s	b	Z	L	n		G	Dinámica C Dynamic C				Estática C ₀ Static C ₀
	mm/inch																	
UFL000	10	60	45	5,5	5,5	11,5	7	36	15,5	14	4	4	M6	4322	1852	U000	FL000	0,063
UFL001	12	63	48	5,5	5,5	11,5	7	38	19	14,5	4	4	M6	4845	2280	U001	FL001	0,076
UFL002	15	67	53	6,5	6,5	13	7	42	20,5	16,5	4,5	4	M6	5320	2707	U002	FL002	0,100
UFL003	17	71	56	7	7	14	7	46	22,5	17,5	5	4	M6	5700	3087	U003	FL003	0,129
UFL004	20	90	71	8	8	16	10	55	26,5	21	6	4,5	M8	8930	4797	U004	FL004	0,205
UFL005	25	95	75	8	8	16	10	60	27,5	22,5	6	5	M8	9595	5557	U005	FL005	0,244
UFL006	30	112	85	9	9	18	13	70	29,5	24,5	6,5	5	M10	12540	7837	U006	FL006	0,354
UFL007	35	122	95	10	10	20	13	80	32,5	27,5	7	6	M10	14750	9750	U007	FL007	0,498

Disponibile bajo demanda en acero inox. soporte: AISI 304 - Rodamiento: AISI 440C - Available under request stainless steel housing: AISI 304 - Bearing: AISI 440C
 Bajo demanda suministrables también con anillo excéntrico de fijación - Under request available with eccentric collar locking

Soportes serie ligera de aleación de aluminio, fijación con pasadores. Un nuevo concepto de soporte que ofrece una significativa reducción del peso y del espacio ocupado comparado con las series normales y que permite además un ahorro en términos económicos en la fase de diseño de la maquinaria.
 Extra light duty bearing units available with set screws, a totally new concept in bearing units, offer a significant reduction in size and weight when compared with the same size of existing series. This unique design promotes both space and material saving in machine tool and general equipment application.

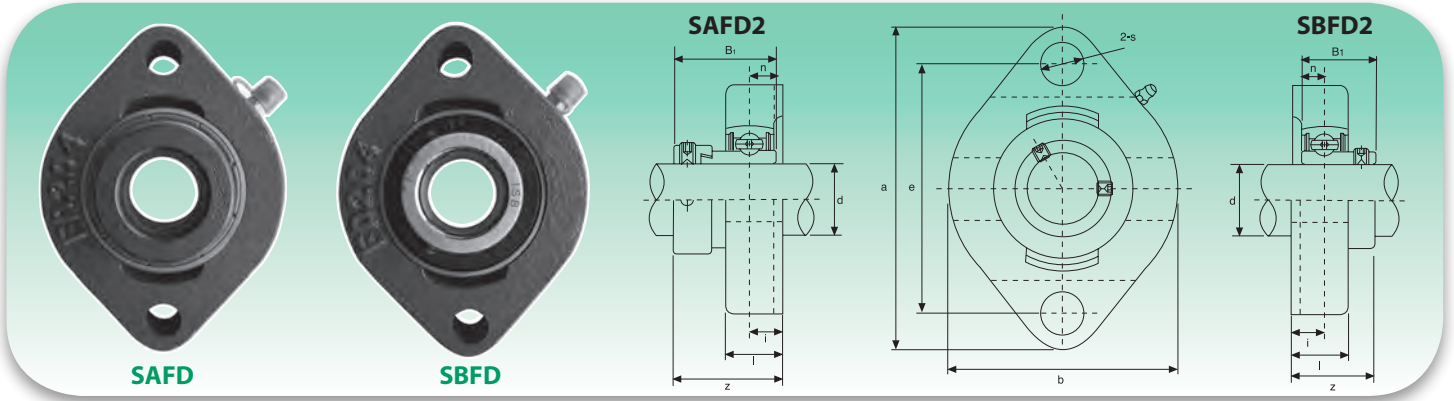
SAFD2 - SBFD2

Tipo Type	Dimensiones - Dimensions							Bul. fij. Bolt Size	SAFD			Rodamiento Bearing	Peso Weight	SBFD			Rodamiento Bearing	Peso Weight	Soporte Housing	Coeficientes de carga (N) Load ratings (N)	
	d	a	e	b	i	s	l		z	B ₁	n			z	B ₁	n				Dinámica C Dynamic C	Estática C ₀ Static C ₀
	mm/inch								mm/inch					mm/inch							
SAFD-SBFD 201 201-8	12 ¾	81 33/16	63 231/64	59 221/64	8,5 21/64	7 9/32	15 19/32	M6 ¼	30,6 113/64	28,6 1,1260	6,5 0,2559	SA201 SA201-8	0,3 61/64	24 0,8661	22 0,2362	6 6	SB201 SB201-8	0,3	FD203	9200	4480
SAFD-SBFD 202 202-9 202-10	15 9/16 5/8	81 33/16	63 231/64	59 221/64	8,5 21/64	7 9/32	15 19/32	M6 ¼	30,6 113/64	28,6 1,1260	6,5 0,2559	SA202 SA202-9 SA202-10	0,3 61/64	24 0,8661	22 0,2362	6 6	SB202 SB202-9 SB202-10	0,3	FD203	9200	4480
SAFD-SBFD 203 203-11	17 11/16	81 33/16	63 231/64	59 221/64	8,5 21/64	7 9/32	15 19/32	M6 ¼	30,6 113/64	28,6 1,1260	6,5 0,2559	SA203 SA203-11	0,3 61/64	24 0,8661	22 0,2362	6 6	SB203 SB203-11	0,3	FD203	9200	4480
SAFD-SBFD 204 204-12	20 ¾	90 335/64	71 251/64	67 241/64	9,5 3/8	10 25/64	17 43/64	M8 5/16	33 119/64	31 1,2204	7,5 0,2953	SA204 SA204-12	0,5 15/64	27,5 0,9843	25 0,2756	7 7	SB204 SB204-12	0,4	FD204	12200	6300
SAFD-SBFD 205 205-13 205-14 205-15 205-16	25 13/16 7/8 15/16 1	95 33/8 3¾	76 263/64	71 251/64	9,5 3/8	10 25/64	17 43/64	M8 5/16	33 119/64	31 1,2204	7,5 0,2953	SA205 SA205-13 SA205-14 SA205-15 SA205-16	0,5 19/64	29 1,0630	27 0,2953	7,5 7,5	SB205 SB205-13 SB205-14 SB205-15 SB205-16	0,5	FD205	13300	7460
SAFD-SBFD 206 206-17 206-18 206-19 205-20	30 11/16 11/8 13/16 1¼	113 47/16	90 335/64	84 35/16	12 15/32	12 15/32	21 53/64	M10 3/8	38,7 117/32	35,7 1,4055	9 0,3543	SA206 SA206-17 SA206-18 SA206-19 SA205-20	0,8 111/32	34 1,1811	30 0,3150	8 8	SB206 SB206-17 SB206-18 SB206-19 SB205-20	0,8	FD206	18500	10800
SAFD-SBFD 207 207-20 207-21 207-22 205-23	35 1¼ 15/16 13/8 17/16	125 459/64	100 315/16	94 345/64	12,5 ½	12 15/32	22 7/8	M10 3/8	41,9 121/32	38,9 1,5315	9,5 0,3740	SA207 SA207-20 SA207-21 SA207-22 SA205-23	1,0 127/64	36 1,2598	32 0,3346	8,5 8,5	SB207 SB207-20 SB207-21 SB207-22 SB205-23	0,9	FD207	24500	14600
SAFD-SBFD 208	40	149	120	104	15	14	25	M12	45,7	-	11	SA208	1,4	38	-	9	SA208	1,2	FD208	27700	17000

SALF2 - SBLF2

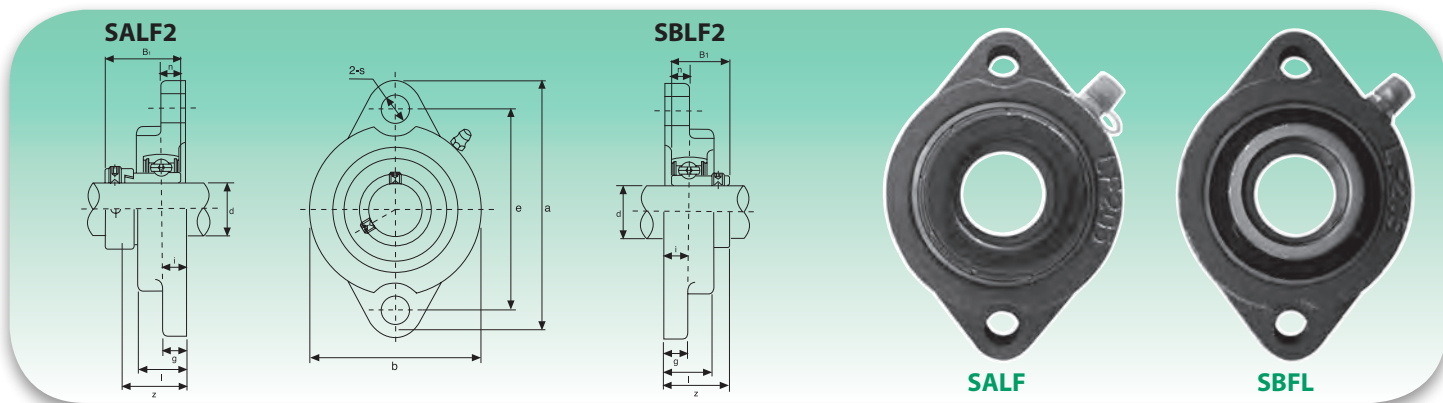

Tipo Type	Dimensiones - Dimensions								Bul. fj. Bolt Size	SALF			Rodamiento Bearing	Peso Weight	SBLF			Rodamiento Bearing	Peso Weight	Soporte Housing	Coeficientes de carga (N) Load ratings (N)	
	d	a	e	b	i	s	g	l		z	B ₁	n			z	B ₁	n				Dinámica C Dynamic C	Estática C ₀ Static C ₀
	mm/inch									mm/inch					mm/inch							
SALF-SBLF 201 201-8	12 ¾	81 33/16	63,5 2½	56 2 13/64	9,5 3/8	8 5/16	9,5 3/8	18 45/64	M6 ¼	31,6 1¼	28,6 1,1260	6,5 0,2559	SA201 SA201-8	0,3 1	25,5 0,8661	22 0,2362	6	SB201 SB201-8	0,3	LF203	9200	4480
SALF-SBLF 202 202-9 202-10	15 9/16 5/8	81 33/16	63,5 2½	56 2 13/64	9,5 3/8	8 5/16	9,5 3/8	18 45/64	M6 ¼	31,6 1¼	28,6 1,1260	6,5 0,2559	SA202 SA202-9 SA202-10	0,3 1	25,5 0,8661	22 0,2362	6	SB202 SB202-9 SB202-10	0,3	LF203	9200	4480
SALF-SBLF 203 203-11	17 11/16	81 33/16	63,5 2½	56 2 13/64	9,5 3/8	8 5/16	9,5 3/8	18 45/64	M6 ¼	31,6 1¼	28,6 1,1260	6,5 0,2559	SA203 SA203-11	0,3 1	25,5 0,8661	22 0,2362	6	SB203 SB203-11	0,3	LF203	9200	4480
SALF-SBLF 204 204-12	20 ¾	90 35/64	71,5 2 13/16	61 2 13/32	11 7/16	10 25/64	11 7/16	20 25/32	M8 5/16	34,5 1 23/64	31 1,2204	7,5 0,2953	SA204 SA204-12	0,4 19/64	29 0,9843	25 0,2756	7	SB204 SB204-12	0,3	LF204	12200	6300
SALF-SBLF 205 205-13 205-14 205-15 205-16	25 13/16 7/8 15/16 1	95 3 3/4	76 2 3/64	64 2 33/64	11 7/16	10 25/64	11 7/16	20 25/32	M8 5/16	34,5 1 23/64	31 1,2204	7,5 0,2953	SA205 SA205-13 SA205-14 SA205-15 SA205-16	0,5 113/64	30,5 1,0630	27 0,2953	7,5	SB205 SB205-13 SB205-14 SB205-15 SB205-16	0,4	LF205	13300	7460
SALF-SBLF 206 206-17 206-18 206-19 205-20	30 11/16 11/8 13/16 1¼	113 47/16	90,5 3 39/16	76 3	12 15/32	12 15/32	12 15/32	22,5 57/64	M10 3/8	38,7 1 33/64	35,7 1,4055	9 0,3543	SA206 SA206-17 SA206-18 SA206-19 SA206-20	0,7 111/32	34 1,1811	30 0,3150	8	SB206 SB206-17 SB206-18 SB206-19 SB206-20	0,6	LF206	18500	10800
SALF-SBLF 207 207-20 207-21 207-22 205-23	35 1¼ 15/16 13/8 17/16	122 4 13/16	100 3 15/16	89 3 1/2	13 33/64	12 15/32	13 33/64	24 61/64	M10 3/8	42,4 1 43/64	38,9 1,5315	9,5 0,3740	SA207 SA207-20 SA207-21 SA207-22 SA207-23	0,9 17/16	36,5 1,2598	32 0,3346	8,5	SB207 SB207-20 SB207-21 SB207-22 SB207-23	0,8	LF207	24500	14600

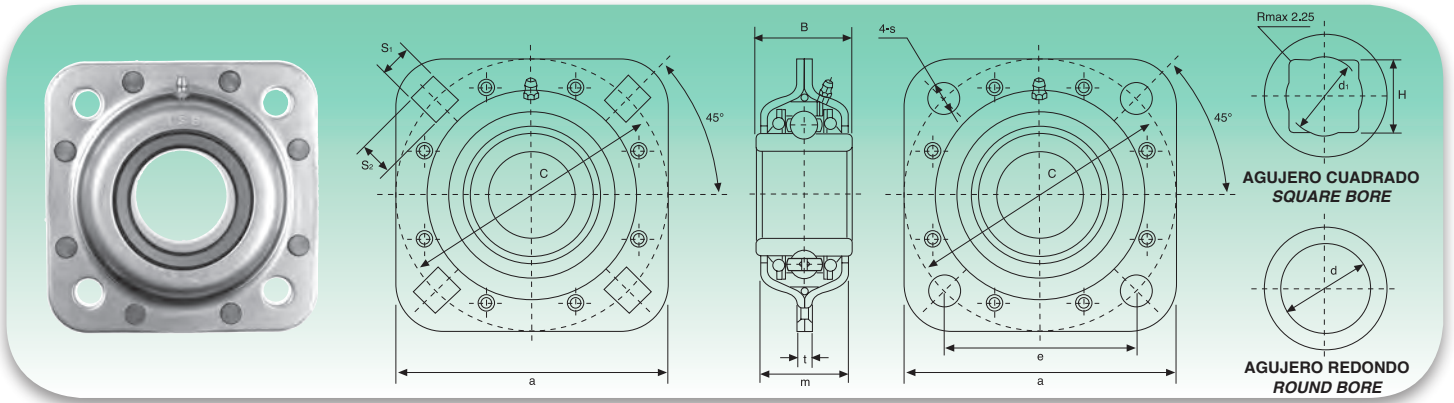

Tipo Type	Dimensiones - Dimensions												Coeficientes de carga (N) Load ratings (N)	
	H	d	a	B	m	t	C	s	s ₁	s ₂	d ₁	e	Dinámica C Dynamic C	Estática C ₀ Static C ₀
	mm/inch													
ST209-11/8	29,972	-	127	42,8	42	6	127	13,5	13,5	17,45	32,0	-	24360	17710
ST209-30S	31,353	-	127	42,8	42	6	127	13,5	13,5	17,45	34,5	-	24360	17710
ST209-1¼	32,766	-	127	42,8	42	6	127	13,5	13,5	17,45	34,5	-	24360	17710
ST491B	-	38,860	127	42,8	42	6	127	13,5	13,5	17,45	-	-	24360	17710
ST209-40R	-	40,878	127	42,8	42	6	127	13,5	13,5	17,45	-	-	24360	17710
ST491A	-	45,000	127	42,8	42	6	127	13,5	13,5	17,45	-	90	24360	17710
ST209-45R	-	45,340	127	42,8	42	6	127	13,5	13,5	17,45	-	-	24360	17710
ST491A¹⁾	-	45,000	121	46	42	6	121	13,5	-	-	-	85	24360	17710
ST211-1½	38,890	-	139,7	50,8	46	8	139,7	13,5	13,5	17,45	42,0	-	33370	25110
ST211-40S	40,878	-	139,7	50,8	46	8	139,7	13,5	13,5	17,45	43,1	-	33370	25110
ST211-50R	-	50,400	139,7	50,8	46	8	139,7	13,5	13,5	17,45	-	-	33370	25110
ST211-55R	-	55,575	139,7	50,8	46	8	139,7	13,5	13,5	17,45	-	-	33370	25110
ST211-1¾	-	45,212	139,7	55,6	46	8	139,7	13,5	13,5	17,45	-	-	33370	25110
ST211-23/16	-	55,575	139,7	55,6	46	8	139,7	13,5	13,5	17,45	-	-	33370	25110
ST211-115/16	-	49,238	139,7	69,9	46	8	139,7	13,5	13,5	17,45	-	-	33370	25110
ST211	-	55,000	139,7	55,6	46	8	139,7	13,5	13,5	17,45	-	-	33370	25110
ST740	-	55,562	139,7	55,6	45	7	139,7	13,5	13,5	17,45	-	98	33370	25110

¹⁾ Dimensiones especiales - Special dimensions

BPP2-SA - BPP2-SB Serie ligera - Light duty

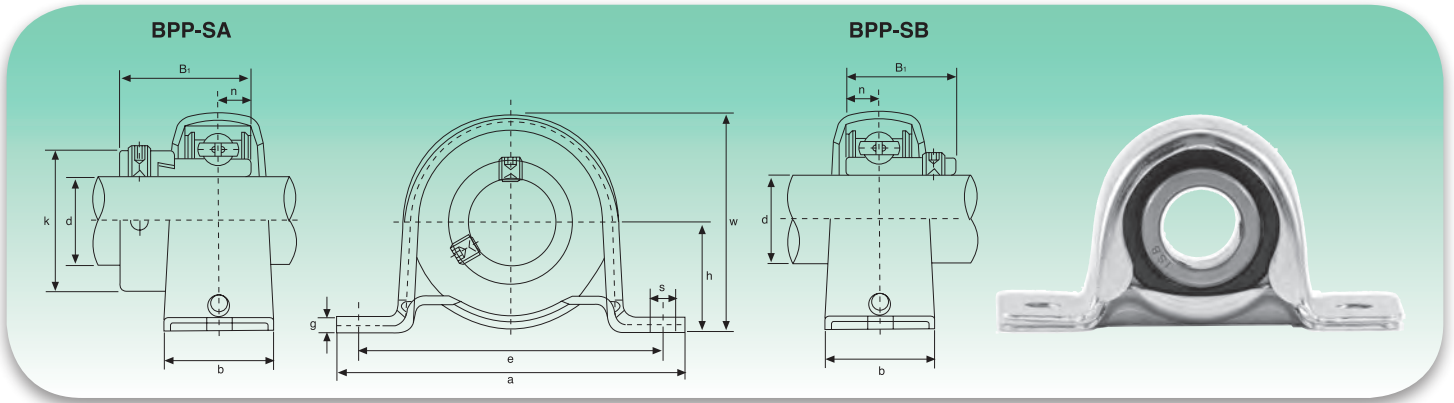

Tipo Type	Dimensiones - Dimensions								Bul. fij. Bolt Size	BPP-SA		Rodamiento Bearing	Peso Weight kg	BPP-SB		Rodamiento Bearing	Peso Weight kg	Soporte Housing	Coeficientes de carga (N) Load ratings (N)	
	d	h	a	e	b	s	g	w		B ₁	n			B ₁	n				Dinámica C Dynamic C	Estática C ₀ Static C ₀
	mm/inch									mm/inch										
BPP-SA BPP-SB 201 201-8	12 ¾	22,2 7/8	86 33/8	68 2 3/4	25 1 3/4	9,5 3/8	3,2 1/16	43,8 1 3/4	M8 5/16	28,6 1,1260	6,5 0,2559	SA201 SA201-8	0,19	22 0,8661	6 0,2362	SB201 SB201-8	0,19	PP203	9200	4480
BPP-SA BPP-SB 202 202-9 202-10	15 9/16 5/8	22,2 7/8	86 33/8	68 2 3/4	25 1 3/4	9,5 3/8	3,2 1/16	43,8 1 3/4	M8 5/16	28,6 1,1260	6,5 0,2559	SA202 SA202-9 SA202-10	0,19	22 0,8661	6 0,2362	SB202 SB202-9 SB202-10	0,19	PP203	9200	4480
BPP-SA BPP-SB 203 203-11	17 1 1/16	22,2 7/8	86 33/8	68 2 3/4	25 1 3/4	9,5 3/8	3,2 1/16	43,8 1 3/4	M8 5/16	28,6 1,1260	6,5 0,2559	SA203 SA203-11	0,19	22 0,8661	6 0,2362	SB203 SB203-11	0,19	PP203	9200	4480
BPP-SA BPP-SB 204 204-12	20 ¾	25,4 1	98 3 7/8	76 2 9/8	32 1 1/4	9,5 3/8	3,2 1/16	50,6 1 9/8	M8 5/16	31 1,2204	7,5 0,2953	SA204 SA204-12	0,23	25 0,9843	7 0,2756	SB204 SB204-12	0,23	PP204	12200	6300
BPP-SA BPP-SB 205 205-13 205-14 205-15 205-16	25 1 3/16 7/8 15/16 1	28,6 1 1/8	108 4 1/4	86 3 1/4	32 1 1/4	11,5 29/64	4 0,157	56,6 2 1/8	M10 3/8	31 1,2204	7,5 0,2953	SA205 SA205-13 SA205-14 SA205-15 SA205-16	0,32	27 1,0630	7,5 0,2953	SB205 SB205-13 SB205-14 SB205-15 SB205-16	0,28	PP205	13300	7460
BPP-SA BPP-SB 206 206-17 206-18 206-19 206-20	30 1 1/16 1 1/8 13/16 1 1/4	33,3 1 1/8	117 4 3/8	95 3 7/8	38 1 1/2	11,5 29/64	4 0,157	66,3 2 5/8	M10 3/8	35,7 1,4055	9 0,3543	SA206 SA206-17 SA206-18 SA206-19 SA206-20	0,50	30 1,1811	8 0,3150	SB206 SB206-17 SB206-18 SB206-19 SB206-20	0,47	PP206	18500	10800
BPP-SA BPP-SB 207 207-20 207-21 207-22 207-23	35 1 1/4 15/16 13/8 17/16	39,7 1 5/8	129 5 1/8	106 4 1/4	42 1 1/2	11,5 29/64	4,6 0,181	78 3 1/8	M10 3/8	38,9 1,5315	9,5 0,3740	SA207 SA207-20 SA207-21 SA207-22 SA207-23	0,71	32 1,2598	8,5 0,3346	SB207 SB207-20 SB207-21 SB207-22 SB207-23	0,57	PP207	24500	14600
BPP-SA BPP-SB 208 208-24 208-25	40 1 1/2 19/16	43,7 1 7/8	148 5 7/8	120 4 3/4	43 1 11/16	12 30/64	5 0,196	86,5 3 3/8	M10 3/8	43,7 1,721	11 0,4331	SA208 SA208-24 SA208-25	0,95	34 1,3386	9 0,3543	SB208 SB208-24 SB208-25	0,80	PP208	27700	17000

Disponible en acero inox. Soporte: AISI 304 - Rodamiento: AISI 440C - Available stainless steel Housing: AISI 304 - Bearing: AISI 440C

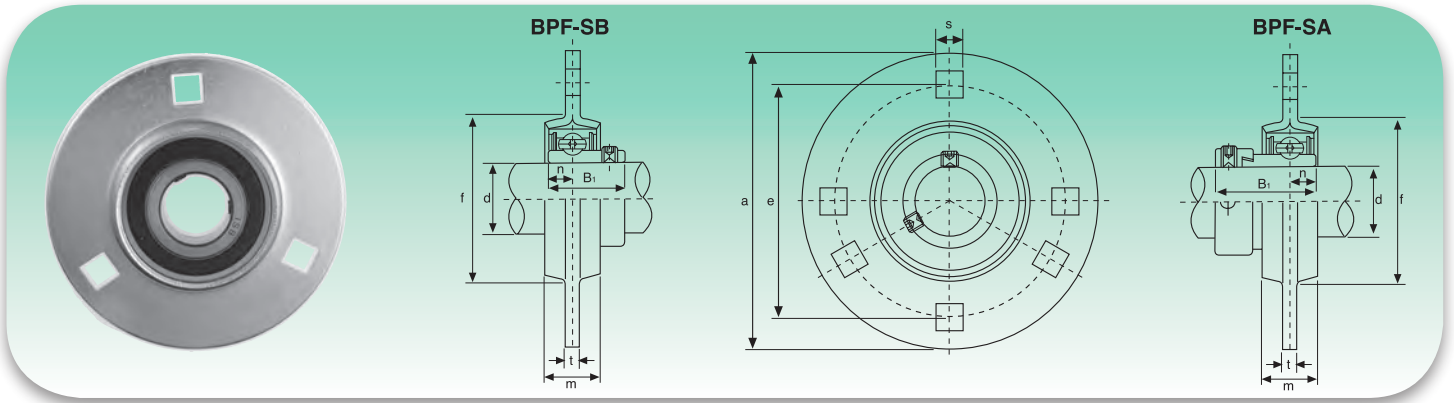

Tipo Type	Dimensiones - Dimensions								Bul. fij. Bolt Size	BPF-SA		Rodamiento Bearing	BPF-SB		Rodamiento Bearing	Peso Weight	Soporte Housing	Coeficientes de carga (N) Load ratings (N)	
	d	a	e	m	s	t	f(min)	B ₁		n	B ₁		n	Dinámica C Dynamic C				Estática C ₀ Static C ₀	
	mm/inch									mm/inch			mm/inch						
BPF-SA BPF-SB 201 201-8	12 ¾	81 33/16	63,5 2½	14 9/16	7,1 9/32	4 0,157	49 159/64	M6 ¼	28,6 1,1260	6,5 0,2559	SA201 SA201-8	0,3	22 0,8661	6 0,2362	SB201 SB201-8	0,27	PF203	9200	4480
BPF-SA BPF-SB 202 202-9 202-10	15 9/16 5/8	81 33/16	63,5 2½	14 9/16	7,1 9/32	4 0,157	49 159/64	M6 ¼	28,6 1,1260	6,5 0,2559	SA202 SA202-9 SA202-10	0,3	22 0,8661	6 0,2362	SB202 SB202-9 SB202-10	0,27	PF203	9200	4480
BPF-SA BPF-SB 203 203-11	17 11/16	81 33/16	63,5 2½	14 9/16	7,1 9/32	4 0,157	49 159/64	M6 ¼	28,6 1,1260	6,5 0,2559	SA203 SA203-11	0,3	22 0,8661	6 0,2362	SB203 SB203-11	0,27	PF203	9200	4480
BPF-SA BPF-SB 204 204-12	20 ¾	90 335/64	71,5 2 13/16	16 5/8	9 23/64	4 0,157	56 213/64	M8 5/16	31 1,2204	7,5 0,2953	SA204 SA204-12	0,33	25 0,9843	7 0,2756	SB204 SB204-12	0,33	PF204	12200	6300
BPF-SA BPF-SB 205 205-13 205-14 205-15 205-16	25 13/16 7/8 15/16 1	95 3 3/4	76 253/64	18 23/32	9 223/64	4 0,157	60 223/64	M8 5/16	31 1,2204	7,5 0,2953	SA205 SA205-13 SA205-14 SA205-15 SA205-16	0,42	27 1,0630	7,5 0,2953	SB205 SB205-13 SB205-14 SB205-15 SB205-16	0,38	PF205	13300	7460
BPF-SA BPF-SB 206 206-17 206-18 206-19 206-20	30 11/16 11/8 13/16 1¼	113 47/16	90,5 39/16	18 23/32	11 7/16	5,2 0,205	71 251/64	M10 3/8	35,7 1,4055	9 0,3543	SA206 SA206-17 SA206-18 SA206-19 SA206-20	0,65	30 1,1811	8 0,3150	SB206 SB206-17 SB206-18 SB206-19 SB206-20	0,62	PF206	18500	10800
BPF-SA BPF-SB 207 207-20 207-21 207-22 207-23	35 1¼ 15/16 13/8 17/16	122 413/16	100 315/16	20 25/32	11 7/16	5,2 0,205	81 33/16	M10 3/8	38,9 1,5315	9,5 0,3740	SA207 SA207-20 SA207-21 SA207-22 SA207-23	0,9	32 1,2598	8,5 0,3346	SB207 SB207-20 SB207-21 SB207-22 SB207-23	0,82	PF207	24500	14600
BPF-SA BPF-SB 208 208-24 208-25	40 1½ 19/16	148 513/16	119 411/16	21 13/16	13,5 17/32	6,8 0,268	91 337/64	M12 ½	43,7 1,7205	11 0,4331	SA208 SA208-24 SA208-25	1,15	34 1,3386	9 0,3543	SB208 SB208-24 SB208-25	1,1	PF208	27700	17000

Disponible en acero inox. Soporte: AISI 304 - Rodamiento: AISI 440C - Available stainless steel Housing: AISI 304 - Bearing: AISI 440C

BPFL2-SA - BPFL2-SB Serie ligera - Light duty

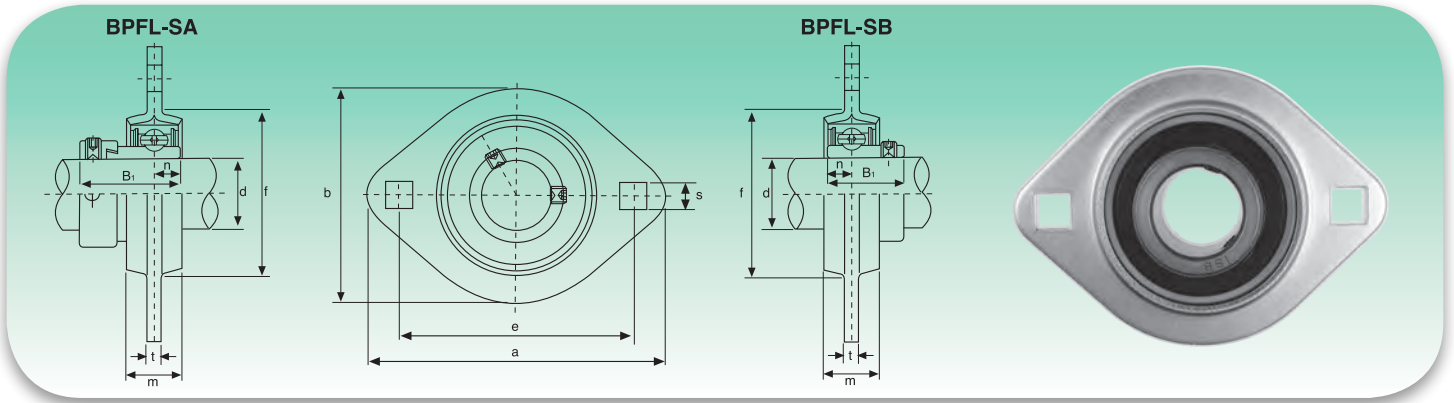

Tipo Type	Dimensiones - Dimensions								Bul. fij. Bolt Size	BPFL-SA		Rodamiento Bearing	Peso Weight	BPFL-SB		Rodamiento Bearing	Peso Weight	Soporte Housing	Coeficientes de carga (N) Load ratings (N)	
	d	a	e	b	m	s	t	f(min)		B ₁	n			B ₁	n				Dinámica C Dynamic C	Estática C ₀ Static C ₀
	mm/inch									mm/inch				mm/inch						
BPFL-SA BPFL-SB 201	12	81	63,5	59	14	7,1	4	49	M6	28,6	6,5	SA201	0,22	22	6	SB201	0,19	PFL203	9200	4480
201-8	¾	33/16	2½	221/64	9/16	159/64	0,157	159/64	¼	1,1260	0,2559	SA201-8		0,8661	0,2362	SB201-8				
BPFL-SA BPFL-SB 202	15	81	63,5	59	14	7,1	4	49	M6	28,6	6,5	SA202	0,22	22	6	SB202	0,19	PFL203	9200	4480
202-9	9/16											SA202-9				SB202-9				
202-10	5/8	33/16	2½	221/64	9/16	159/64	0,157	159/64	¼	1,1260	0,2559	SA202-10		0,8661	0,2362	SB202-10				
BPFL-SA BPFL-SB 203	17	81	63,5	59	14	7,1	4	49	M6	28,6	6,5	SA203	0,22	22	6	SB203	0,19	PFL203	9200	4480
203-11	11/16	33/16	2½	221/64	9/16	159/64	0,157	159/64	¼	1,1260	0,2559	SA203-11		0,8661	0,2362	SB203-11				
BPFL-SA BPFL-SB 204	20	90	71,5	67	16	9	4	56	M8	31	7,5	SA204	0,24	25	7	SB204	0,24	PFL204	12200	6300
204-12	¾	35/64	213/64	241/64	5/8	23/64	0,157	213/64	5/16	1,2204	0,2953	SA204-12		0,9843	0,2756	SB204-12				
BPFL-SA BPFL-SB 205	25	95	76	71	18	9	4	60	M8	31	7,5	SA205	0,32	27	7,5	SB205	0,28	PFL205	13300	7460
205-13	13/16											SA205-13				SB205-13				
205-14	7/8	3¾	253/64	251/64	23/32	23/64	0,157	223/64	5/16	1,2204	0,2953	SA205-14		1,0630	0,2953	SB205-14				
205-15	15/16											SA205-15				SB205-15				
205-16	1											SA205-16				SB205-16				
BPFL-SA BPFL-SB 206	30	113	90,5	84	18	11	5,2	71	M10	35,7	9	SA206	0,41	30	8	SB206	0,38	PFL206	18500	10800
206-17	11/16											SA206-17				SB206-17				
206-18	11/8											SA206-18				SB206-18				
206-19	13/16	47/16	39/16	35/16	23/32	7/16	0,205	251/64	3/8	1,4055	0,3543	SA206-19		1,1811	0,3150	SB206-19				
206-20	1¼											SA206-20				SB206-20				
BPFL-SA BPFL-SB 207	35	122	100	94	20	11	5,2	81	M10	38,9	9,5	SA207	0,52	32	8,5	SB207	0,50	PFL207	24500	14600
207-20	1¼											SA207-20				SB207-20				
207-21	15/16											SA207-21				SB207-21				
207-22	13/8	413/16	315/16	345/64	25/32	7/16	0,205	33/16	3/8	1,5315	0,3740	SA207-22		1,2598	0,3346	SB207-22				
207-23	17/16											SA207-23				SB207-23				
BPFL-SA BPFL-SB 208	40	148	119	100	21	13,5	6,8	91	M12	43,7	11	SA208	0,83	34	9	SB208	0,80	PFL208	27700	17000
208-24	1½											SA208-24				SB208-24				
208-25	19/16	513/16	411/16	315/16	13/16	17/32	0,268	337/64	½	1,7205	0,4331	SA208-25		1,3386	0,3543	SB208-25				

Disponible en acero inox. Soporte: AISI 304 - Rodamiento: AISI 440C - Available stainless steel Housing: AISI 304 - Bearing: AISI 440C

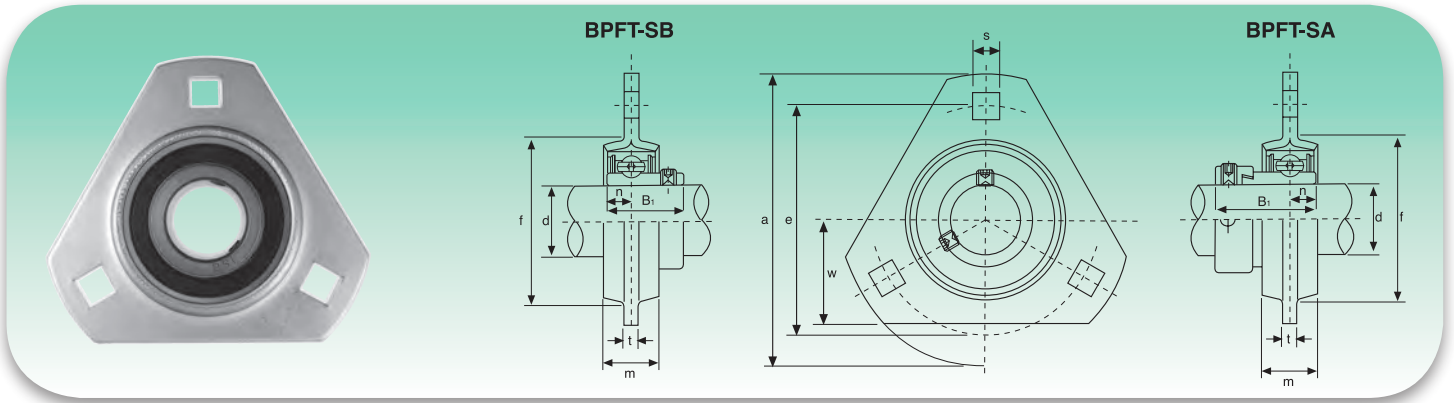
BPFT2-SA - BPFT2-SB Serie ligera - Light duty

Tipo Type	Dimensiones - Dimensions								Bul. fij. Bolt Size	BPFT-SA		Rodamiento Bearing	Peso Weight	BPFT-SB		Rodamiento Bearing	Peso Weight	Soporte Housing	Coeficientes de carga (N) Load ratings (N)	
	d	a	e	w	m	s	t	f _(min)		B ₁	n			B ₁	n				Dinámica C Dynamic C	Estática C ₀ Static C ₀
	mm/inch									mm/inch				mm/inch					kg	
BPFT-SA BPFT-SB 201 201-8	12 ¾	81 33/16	63,5 2½	28,5 1 1/8	14 9/16	7,1 9/32	4 0,157	49 1 59/64	M6 ¼	28,6 1,1260	6,5 0,2559	SA201 SA201-8	0,26	22 0,8661	6 0,2362	SB201 SB201-8	0,23	PFT203	9200	4480
BPFT-SA BPFT-SB 202 202-9 202-10	15 9/16 5/8	81 33/16	63,5 2½	28,5 1 1/8	14 9/16	7,1 9/32	4 0,157	49 1 59/64	M6 ¼	28,6 1,1260	6,5 0,2559	SA202 SA202-9 SA202-10	0,26	22 0,8661	6 0,2362	SB202 SB202-9 SB202-10	0,23	PFT203	9200	4480
BPFT-SA BPFT-SB 203 203-11	17 11/16	81 33/16	63,5 2½	28,5 1 1/8	14 9/16	7,1 9/32	4 0,157	49 1 59/64	M6 ¼	28,6 1,1260	6,5 0,2559	SA203 SA203-11	0,26	22 0,8661	6 0,2362	SB203 SB203-11	0,23	PFT203	9200	4480
BPFT-SA BPFT-SB 204 204-12	20 ¾	90 35/64	71,5 2 13/64	33 1 19/64	16 5/8	9 23/64	4 0,157	56 2 13/64	M8 5/16	31 1,2204	7,5 0,2953	SA204 SA204-12	0,28	25 0,9843	7 0,2756	SB204 SB204-12	0,28	PFT204	12200	6300
BPFT-SA BPFT-SB 205 205-13 205-14 205-15 205-16	25 13/16 7/8 15/16 1	95 3 3/4	76 2 33/64	35 1 3/8	18 23/32	9 23/64	4 0,157	60 2 23/64	M8 5/16	31 1,2204	7,5 0,2953	SA205 SA205-13 SA205-14 SA205-15 SA205-16	0,36	27 1,0630	7,5 0,2953	SB205 SB205-13 SB205-14 SB205-15 SB205-16	0,36	PFT205	13300	7460
BPFT-SA BPFT-SB 206 206-17 206-18 206-19 206-20	30 11/16 11/8 13/16 1¼	113 47/16	90,5 3 9/16	40 1 37/64	18 23/32	11 7/16	5,2 0,205	71 2 51/64	M10 3/8	35,7 1,4055	9 0,3543	SA206 SA206-17 SA206-18 SA206-19 SA206-20	0,58	30 1,1811	8 0,3150	SB206 SB206-17 SB206-18 SB206-19 SB206-20	0,55	PFT206	18500	10800
BPFT-SA BPFT-SB 207 207-20 207-21 207-22 207-23	35 1¼ 15/16 13/8 17/16	122 4 13/16	100 3 15/16	44,5 1 3/4	20 25/32	11 7/16	5,2 0,205	81 3 33/64	M10 3/8	38,9 1,5315	9,5 0,3740	SA207 SA207-20 SA207-21 SA207-22 SA207-23	0,82	32 1,2598	8,5 0,3346	SB207 SB207-20 SB207-21 SB207-22 SB207-23	0,74	PFT207	24500	14600
BPFT-SA BPFT-SB 208 208-24 208-25	40 1½ 19/16	148 5 13/16	119 4 11/16	55 2 1/8	23 29/32	13,5 0,531	5,8 0,228	85 3,646	M15 7/16	43,7 1,7201	11 0,4331	SA208 SA208-24 SA208-25	1,05	34 -	9 0,3543	SB208 SB208-24 SB208-25	0,90	PFT208	27700	17000

Disponible en acero inox. Soporte: AISI 304 - Rodamiento: AISI 440C - Available stainless steel Housing: AISI 304 - Bearing: AISI 440C

RODAMIENTOS

BEARING



SOPORTES DE PIE PARTIDOS

PLUMMER BLOCKS

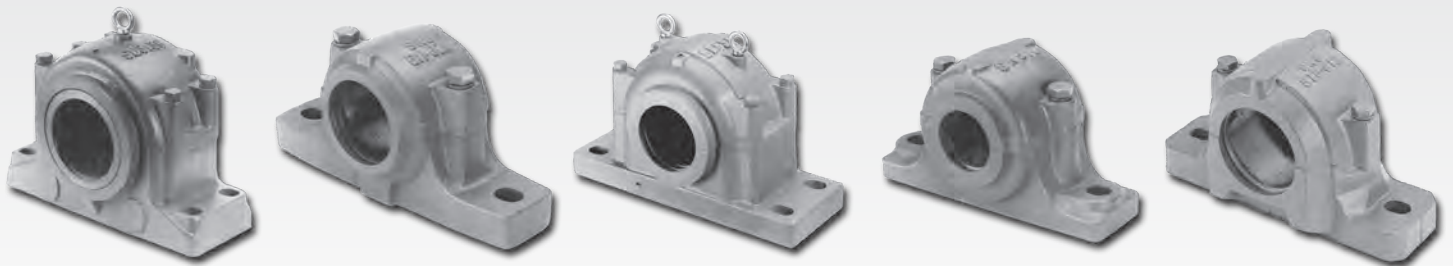

SOPORTES DE BRIDA

HOUSINGS



SOPORTES DE PLÁSTICO

PLASTIC BEARING UNITS

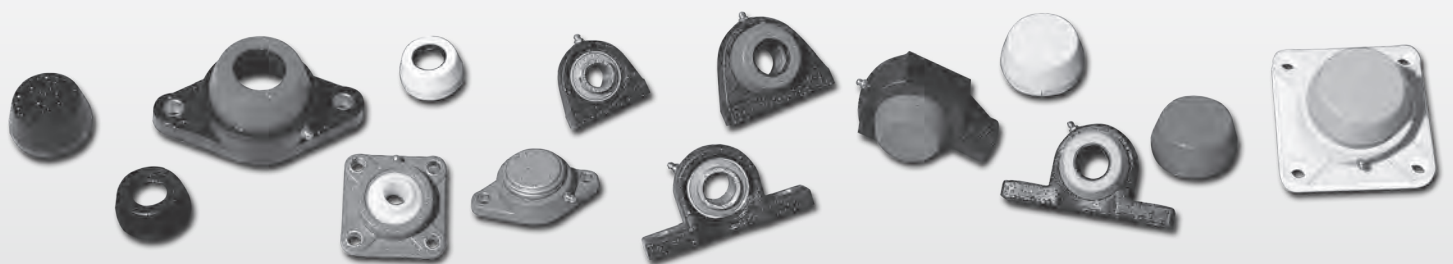

SOPORTES PARA HUSILLOS DE BOLAS

SUPPORTS OF BALL SCREWS

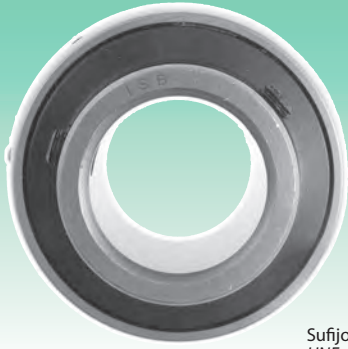

UC2 Serie normal - Standard duty

Sufijo UNF: Medidas en pulgadas de los pasadores de fijación
UNF suffix: inch sizes set screws

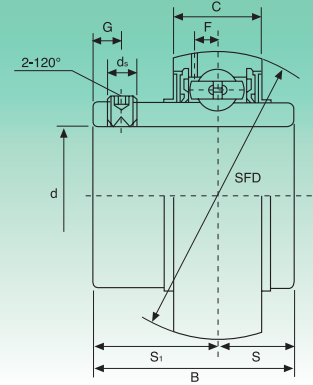

Tipo Type	Dimensiones - Dimensions									Coeficientes de carga (N) Load ratings (N)		Peso Weight kg	
	d	D	B	C	S	S ₁	G	ds	F	Dinámica C _d Dynamic C _d	Estática C ₀ Static C ₀		
	mm/inch												
UC201	12	47	31	17	12,7	18,3	4,8	M6x1	3,7	12160	6318	0,20	
UC201-8	3/4	1,8504	1,2205	0,6693	0,500	0,720	0,189	1/4-28UNF	0,146				0,19
UC202	15	47	31	17	12,7	18,3	4,8	M6x1	3,7	12160	6318	0,19	
UC202-9	9/16	1,8504	1,2205	0,6693	0,500	0,720	0,189	1/4-28UNF	0,146				0,19
UC202-10	5/8	1,8504	1,2205	0,6693	0,500	0,720	0,189	1/4-28UNF	0,146	0,19	0,19		
UC203	17	47	31	17	12,7	18,3	4,8	M6x1	3,7	12160	6318	0,18	
UC203-11	11/16	1,8504	1,2205	0,6693	0,500	0,720	0,189	1/4-28UNF	0,146				0,17
UC204	20	47	31	17	12,7	18,3	4,8	M6x1	3,7	12160	6318	0,16	
UC204-12	3/4	1,8504	1,2205	0,6693	0,500	0,720	0,189	1/4-28UNF	0,146				0,16
UC205	25	52	34,1	17	14,3	19,8	5	M6x1	3,9	13300	7457	0,20	
UC205-13	13/16												0,24
UC205-14	7/8												0,23
UC205-15	15/16	2,0472	1,3425	0,6693	0,563	0,780	0,197	1/4-28UNF	0,154				0,21
UC205-16	1												0,20
UC206	30	62	38,1	19	15,9	22,2	5	M6x1	5,0	18525	10735	0,32	
UC206-17	11/16												0,33
UC206-18	11/8												0,34
UC206-19	13/16	2,4409	1,5000	0,7480	0,626	0,874	0,197	1/4-28UNF	0,197				0,32
UC206-20	1 1/4												0,31
UC207	35	72	42,9	20	17,5	25,4	7	M8x1	5,7	24415	14630	0,48	
UC207-20	1 1/4												0,54
UC207-21	15/16												0,51
UC207-22	13/8	2,8346	1,6890	0,7874	0,689	1,000	0,276	5/16-24UNF	0,224				0,48
UC207-23	17/16												0,45
UC208	40	80	49,2	21	19	30,2	8	M8x1	6,2	27645	16910	0,64	
UC208-24	1 1/2												0,68
UC208-25	19/16	3,1496	1,9370	0,8268	0,748	1,189	0,315	5/16-24UNF	0,244				0,65
UC209	45	85	49,2	22	19	30,2	8	M8x1	6,4	32395	20235	0,68	
UC209-26	15/8												0,78
UC209-27	111/16	3,3465	1,9370	0,8661	0,748	1,189	0,315	5/16-24UNF	0,252				0,74
UC209-28	1 3/4												0,70
UC210	50	90	51,6	24	19	32,6	10	M10x1	6,5	33345	22135	0,80	
UC210-29	113/16												0,92
UC210-30	17/8												0,87
UC210-31	115/16	3,5433	2,0315	0,9449	0,748	1,283	0,394	3/8-24UNF	0,256				0,82
UC210-32	2												0,78
UC211	55	100	55,6	25	22,2	33,4	10	M10x1	7,0	41230	27930	1,11	
UC211-32	2												1,26
UC211-33	21/16												1,20
UC211-34	21/8	3,9370	2,1890	0,9843	0,874	1,315	0,394	3/8-24UNF	0,276				1,15
UC211-35	23/16												1,09
UC212	60	110	65,1	27	25,4	39,7	10	M10x1	7,6	49780	34390	1,54	
UC212-36	2 1/4												1,67
UC212-37	25/16												1,59
UC212-38	23/8	4,3307	2,5630	1,0630	1,000	1,563	0,394	3/8-24UNF	0,299				1,52
UC212-39	27/16									1,45			
UC213	65	120	65,1	28	25,4	39,7	10	M10x1	8,5	54340	38095	1,85	
UC213-40	2 1/2												1,94
UC213-41	29/16	4,7244	2,5630	1,1024	1,000	1,563	0,394	3/8-24UNF	0,335				1,85
UC214	70	125	74,6	29	30,2	44,4	12	M12x1,5	8,9	59090	41895	2,05	
UC214-42	25/8												2,26
UC214-43	211/16	4,9213	2,9370	1,1417	1,189	1,748	0,472	7/16-20UNF	0,350				2,16
UC214-44	2 3/4												2,06
UC215	75	130	77,8	30	33,3	44,5	12	M12x1,5	9,2	64030	45885	2,21	
UC215-45	213/16												2,46
UC215-46	27/8												2,35
UC215-47	215/16	5,1181	3,0630	1,1811	1,311	1,752	0,472	7/16-20UNF	0,362				2,24
UC215-48	3												2,12
UC216	80	140	82,6	32	33,3	49,3	12	M12x1,5	9,5	69065	50350	2,80	
UC216-49	31/16												2,98
UC216-50	31/8	5,5118	3,2520	1,2598	1,311	1,9409	0,472	7/16-20UNF	0,374				2,85
UC216-51	33/16												2,72
UC217	85	150	85,7	34	34,1	51,6	12	M12x1,5	10,2	79800	58805	3,46	
UC217-52	3 1/4												3,68
UC217-53	35/16	5,9055	3,3740	1,3386	1,343	2,031	0,472	7/16-20UNF	0,402				3,54
UC217-55	37/16												3,25
UC218	90	160	96	36	39,7	56,3	12	M12x1,5	11,2	91295	67925	4,36	
UC218-56	3 1/2	6,2992	3,7795	1,4173	1,5630	2,217	0,472	7/16-20UNF	0,441				4,47

Disponible en acero inox AISI 440C - Available stainless steel AISI 440C

HC2 Serie normal - Standard duty

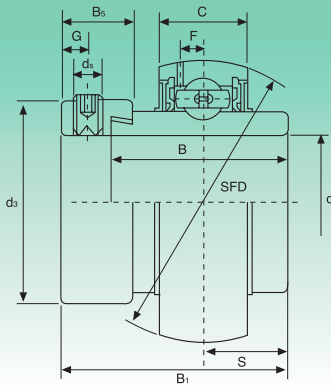

Sufijo UNF: Medidas en pulgadas de los pasadores de fijación
UNF suffix: inch sizes set screws

Tipo Type	Dimensiones - Dimensions											Coeficientes de carga (N) Load ratings (N)		Peso Weight kg
	d	D	B ₁	B	C	S	d _s	G	B _s	d _s	F	Dinámica C Dynamic C	Estática C ₀ Static C ₀	
	mm/inch													
HC204	20	47	43,7	34,2	17	17,1	M6x1	4,8	13,5	33,3	3,7	12160	6318	0,23
HC204-12	13/4	1,8504	1,720	1,3465	0,6693	0,673	1/4-28UNF	0,189	0,531	1,311	0,146			0,23
HC205	25	52	44,4	34,9	17	17,5	M6x1	4,8	13,5	38,1	3,9	13300	7457	0,27
HC205-13	13/16													0,32
HC205-14	7/8													0,31
HC205-15	15/16	2,0472	1,748	1,3740	0,6693	0,689	1/4-28UNF	0,189	0,531	1,500	0,154			0,29
HC205-16	1													0,27
HC206	30	62	48,4	36,5	19	18,3	M8x1	6	15,9	44,5	5,0	18525	10735	0,45
HC206-17	11/16													0,50
HC206-18	11/8													0,47
HC206-19	13/16	2,4409	1,906	1,4370	0,7480	0,720	5/16-24UNF	0,236	0,626	1,752	0,197			0,45
HC206-20	1 1/4													0,42
HC207	35	72	51,1	37,6	20	18,8	M8x1	6,8	17,5	55,6	5,7	24415	14630	0,60
HC207-20	1 1/4													0,67
HC207-21	15/16													0,63
HC207-22	13/8	2,8346	2,012	1,4803	0,7874	0,740	5/16-24UNF	0,268	0,689	2,189	0,224			0,60
HC207-23	17/16													0,57
HC208	40	80	56,3	42,8	21	21,4	M8x1	6,8	18,3	60,3	6,2	27645	16910	0,79
HC208-24	1 1/2													0,84
HC208-25	19/16	3,1496	2,217	1,6850	0,8268	0,843	5/16-24UNF	0,268	0,720	2,374	0,244			0,80
HC209	45	85	56,3	42,8	22	21,4	M8x1	6,8	18,3	63,5	6,4	32395	20235	0,85
HC209-26	15/8													0,96
HC209-27	111/16	3,3465	2,217	1,6850	0,8661	0,843	5/16-24UNF	0,268	0,720	2,5000	0,252			0,91
HC209-28	1 3/4													0,87
HC210	50	90	62,7	49,2	24	24,6	M8x1	6,8	18,3	69,9	6,5	33345	22135	0,99
HC210-29	113/16													1,14
HC210-30	17/8													1,08
HC210-31	115/16	3,5433	2,469	1,9370	0,9449	0,969	5/16-24UNF	0,268	0,720	2,752	0,256			1,02
HC210-32	2													0,96
HC211	55	100	71,4	55,5	25	27,8	M10x1	8	20,7	76,2	7,0	41230	27930	1,32
HC211-32	2													1,52
HC211-33	21/16													1,44
HC211-34	21/8	3,9370	2,811	2,1850	0,9843	1,094	3/8-24UNF	0,315	0,815	3,000	0,276			1,37
HC211-35	23/16													1,29
HC212	60	110	77,8	61,9	27	31	M10x1	8	22,3	84,2	7,6	49780	34390	1,88
HC212-36	2 1/4													2,04
HC212-37	25/16													1,95
HC212-38	23/8	4,3307	3,063	2,4370	1,0630	1,220	3/8-24UNF	0,315	0,878	3,315	0,299			1,90
HC212-39	27/16													1,77
HC213	65	120	85,7	68,6	28	34,1	M10x1	8,5	23,5	86	8,5	54340	38095	2,41
HC213-40	2 1/2													2,51
HC213-41	29/16	4,7244	3,374	2,7008	1,1024	1,343	3/8-24UNF	0,335	0,925	3,386	0,335			2,40
HC214	70	125	85,7	68,6	29	34,1	M10x1	8,5	23,5	90	8,9	59090	41895	2,55
HC214-42	25/8													2,79
HC214-43	211/16	4,9213	3,374	2,7008	1,1417	1,343	3/8-24UNF	0,335	0,925	3,543	0,350			2,68
HC214-44	2 3/4													2,56
HC215	75	130	92,1	75	30	37,3	M10x1	8,5	23,5	102	9,2	64030	45885	2,84
HC215-45	213/16													3,14
HC215-46	27/8													3,01
HC215-47	215/16	5,1181	3,626	2,9528	1,1811	1,469	3/8-24UNF	0,335	0,925	4,016	0,362			2,88
HC215-48	3													2,74

Disponibile en acero inox AISI 440C - Available stainless steel AISI 440C

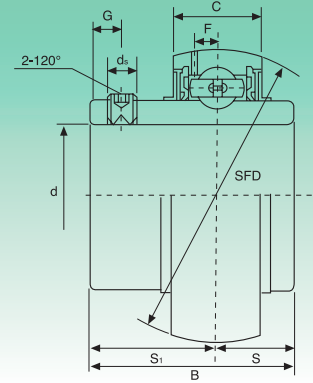
UCX Serie media - Medium duty

Sufijo UNF: Medidas en pulgadas de los pasadores de fijación
UNF suffix: inch sizes set screws

Tipo Type	Dimensiones - Dimensions									Coeficientes de carga (N) Load ratings (N)		Peso Weight kg
	d	D	B	C	S	S ₁	G	ds	F	Dinámica C Dynamic C	Estática C ₀ Static C ₀	
	mm/inch											
UCX05	25	62	38,1	19	15,9	22,2	5	M6x1	5,0			
UCX05-13	13/16											
UCX05-14	7/8	2,4409	1,5000	0,7480	0,626	0,874	0,197	¼-28UNF	0,197	18525	10735	0,39
UCX05-15	15/16											
UCX05-16	1											
UCX06	30	72	42,9	20	17,5	25,4	7	M8x1	5,7			
UCX06-17	11/16											
UCX06-18	11/8	2,8346	1,6890	0,7874	0,689	1,000	0,276	5/16-24UNF	0,224	24415	14630	0,68
UCX06-19	13/16											
UCX06-20	1¼											
UCX07	35	80	49,2	21	19	30,2	8	M8x1	6,2			
UCX07-21	15/16											
UCX07-22	13/8	3,1496	1,9370	0,8268	0,748	1,189	0,315	5/16-24UNF	0,244	27645	16910	0,82
UCX07-23	17/16											
UCX08	40	85	49,2	22	19	30,2	8	M8x1	6,4			
UCX08-24	1½											
UCX08-25	19/16	3,3465	1,9370	0,8661	0,748	1,189	0,315	5/16-24UNF	0,252	32395	20235	0,93
UCX09	45	90	51,6	24	19	32,6	10	M10x1	6,5			
UCX09-26	15/8											
UCX09-27	111/16	3,5433	2,0315	0,9449	0,748	1,283	0,394	3/8-24UNF	0,256	33345	22135	1,00
UCX09-28	1¾											
UCX10	50	100	55,6	25	22,2	33,4	10	M10x1	7,0			
UCX10-30	17/8											
UCX10-31	115/16	3,9370	2,1890	0,9843	0,874	1,315	0,394	3/8-24UNF	0,276	41230	27930	1,35
UCX10-32	2											
UCX11	55	110	65,1	27	25,4	39,7	10	M10x1	7,6			
UCX11-33	21/16											
UCX11-34	21/8	4,3307	2,5630	1,0630	1,000	1,563	0,394	3/8-24UNF	0,299	49780	34390	1,90
UCX11-35	23/16											
UCX11-36	2¼											
UCX12	60	120	65,1	28	25,4	39,7	10	M10x1	8,5			
UCX12-38	23/8											
UCX12-39	27/16	4,7244	2,5630	1,1024	1,000	1,563	0,394	3/8-24UNF	0,335	54340	38095	2,27
UCX13	65	125	74,6	29	30,2	44,4	12	M12x1,5	8,9			
UCX13-40	2½											
UCX13-41	29/16	4,9213	2,9370	1,1417	1,189	1,748	0,472	7/16-20UNF	0,350	59090	41895	2,45
UCX14	70	130	77,8	30	33,3	44,5	12	M12x1,5	9,2			
UCX14-42	25/8											
UCX14-43	211/16	5,1181	3,0630	1,1811	1,311	1,752	0,472	7/16-20UNF	0,362	64030	45885	2,47
UCX14-44	2¾											
UCX15	75	140	82,6	32	33,3	49,3	12	M12x1,5	9,5			
UCX15-45	213/16											
UCX15-46	27/8	5,5118	3,2520	1,2598	1,311	1,9409	0,472	7/16-20UNF	0,374	69065	50350	3,11
UCX15-47	215/16											
UCX15-48	3											
UCX16	80	150	85,7	34	34,1	51,6	12	M12x1,5	10,2			
UCX16-49	31/16											
UCX16-50	31/8	5,9055	3,3740	1,3386	1,343	2,031	0,472	7/16-20UNF	0,402	79800	58805	3,79
UCX16-51	33/16											
UCX17	85	160	96	36	39,7	56,3	12	M12x1,5	11,2			
UCX17-53	35/16											
UCX17-55	37/16	6,2992	3,7795	1,4173	1,5630	2,217	0,472	½-20UNF	0,441	91295	67925	4,82
UCX18	90	170	104	39	42,9	61,1	14	M14x1,5	10,5			
UCX18-56	37/16											
UCX18-57	3½	6,6929	4,0945	1,5354	1,689	2,406	0,511	9/16-18UNF	0,413	103550	77805	5,51
UCX20	100	190	117,5	44	49,2	68,3	16	M16x1,5	11,3			
UCX20-58	313/16											
UCX20-59	37/8											
UCX20-60	315/16											
UCX20-61	4	7,4803	4,6260	1,7323	1,937	2,689	0,630	5/8-18UNF	0,445	126350	99750	8,95
UCX20-62	4											
UCX20-64	4											

UC3 Serie pesada - Heavy duty

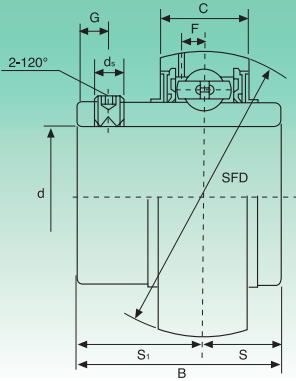

Sufijo UNF: Medidas en pulgadas de los pasadores de fijación
UNF suffix: inch sizes set screws

Tipo Type	Dimensiones - Dimensions									Coeficientes de carga (N) Load ratings (N)		Peso Weight kg
	d	D	B	C	S	S ₁	G	ds	F	Dinámica C Dynamic C	Estática C ₀ Static C ₀	
	mm/inch											
UC305	25	62	38	20	15	23	6	M6x1	5,4			0,35
UC305-13	13/16											0,40
UC305-14	7/8	2,4409	1,4961	0,7874	0,591	0,906	0,236	¼-28UNF	0,213	20140	10355	0,38
UC305-15	15/16											0,36
UC305-16	1											0,35
UC306	30	72	43	23	17	26	6	M6x1	5,7			0,56
UC306-17	11/16											0,61
UC306-18	11/8	2,8346	1,6929	0,9055	0,669	1,024	0,236	¼-28UNF	0,225	25365	14250	0,58
UC306-19	13/16											0,56
UC307	35	80	48	25	19	29	8	M8x1	6,2			0,71
UC307-20	1¼											0,77
UC307-21	15/16	3,1496	1,8898	0,9843	0,748	1,142	0,315	5/16-24UNF	0,224	31730	18335	0,74
UC307-22	13/8											0,71
UC307-23	17/16											0,68
UC308	40	90	52	27	19	33	10	M10x1	7,0			0,96
UC308-24	1½											1,01
UC308-25	19/16	3,5433	2,0472	1,0630	0,748	1,299	0,394	3/8-24UNF	0,276	38665	22800	0,97
UC309	45	100	57	30	22	35	10	M10x1	7,8			1,28
UC309-26	15/8											1,39
UC309-27	111/16	3,9370	2,2441	1,1811	0,866	1,378	0,394	3/8-24UNF	0,307	46455	28025	1,35
UC309-28	1¾											1,30
UC310	50	110	61	32	22	39	12	M12x1,5	8,5			1,65
UC310-29	113/16											1,97
UC310-30	17/8	4,3307	2,4016	1,2598	0,866	1,535	0,472	7/16-20UNF	0,335	58900	36385	1,74
UC310-31	115/16											1,68
UC311	55	120	66	34	25	41	12	M12x1,5	9,2			2,07
UC311-32	2											2,25
UC311-33	21/16	4,7244	2,5984	1,3386	0,984	1,614	0,472	7/16-20UNF	0,362	68020	42750	2,18
UC311-34	21/8											2,12
UC311-35	23/16											2,04
UC312	60	130	71	36	26	45	12	M12x1,5	9,8			2,60
UC312-36	2¼											2,75
UC312-37	25/16	5,1181	2,7953	1,4173	1,0236	1,772	0,472	7/16-20UNF	0,386	77805	49590	2,67
UC312-38	23/8											2,58
UC312-39	27/16											2,50
UC313	65	140	75	38	30	45	12	M12x1,5	10,5			3,25
UC313-40	2½											3,34
UC313-41	29/16	5,5118	2,9528	1,4961	1,181	1,772	0,472	7/16-20UNF	0,413	88065	56905	3,24
UC314	70	150	78	40	33	45	12	M12x1,5	11,1			3,89
UC314-42	25/8											4,11
UC314-43	211/16	5,9055	3,0708	1,5748	1,299	1,772	0,472	7/16-20UNF	0,437	98800	64790	4,00
UC314-44	2¾											3,90
UC315	75	160	82	42	32	50	14	M14x1,5	11,8			4,72
UC315-45	213/16											4,99
UC315-46	27/8	6,2992	3,2283	1,6535	1,260	1,969	0,551	9/16-18UNF	0,465	107350	73340	4,85
UC315-47	215/16											4,76
UC315-48	3											4,63
UC316	80	170	86	44	34	52	14	M14x1,5	12,5			5,55
UC316-49	31/16											5,72
UC316-50	31/8	6,6929	3,3858	1,7323	1,339	2,047	0,551	9/16-18UNF	0,492	116850	82365	5,58
UC316-51	33/16											5,49
UC317	85	180	96	46	40	56	16	M16x1,5	13,1			6,67
UC317-52	3¾											6,89
UC317-53	35/16	7,0866	3,7795	1,8110	1,575	2,205	0,630	5/8-18UNF	0,516	126350	91960	6,76
UC317-55	37/16											6,44
UC318	90	190	96	48	40	56	16	M16x1,5	13,8			7,56
UC318-55	37/16											7,85
UC318-56	3½	7,4803	3,7795	1,8898	1,575	2,205	0,630	5/8-18UNF	0,543	135850	101650	7,67
UC319	95	200	103	50	41	62	16	M16x1,5	14,7			8,70
UC319-58	35/8											9,03
UC319-59	311/16	7,8740	4,0551	1,9685	1,614	2,441	0,630	5/8-18UNF	0,579	145350	113050	8,85
UC319-60	3¾											8,66
UC320	100	215	108	55	42	66	18	M18x1,5	13,5			10,80
UC320-61	313/16											11,20
UC320-62	37/8	8,4646	4,2520	2,1654	1,654	2,598	0,709	5/8-18UNF	0,531	164350	133950	10,98
UC320-63	315/16											10,80
UC320-64	4											10,60
UC321	105	225	112	56	44	68	18	M18x1,5	19,1	174800	145350	12,20
UC322	110	240	117	60	46	71	18	M18x1,5	20,6	194750	171000	14,30
UC324	120	260	126	64	51	75	18	M18x1,5	20,6	196650	175750	18,50
UC326	130	280	135	68	54	81	20	M20x1,5	22,2	217550	203300	23,00
UC328	140	300	145	73	59	86	22	M20x1,5	23,8	240350	233700	28,50

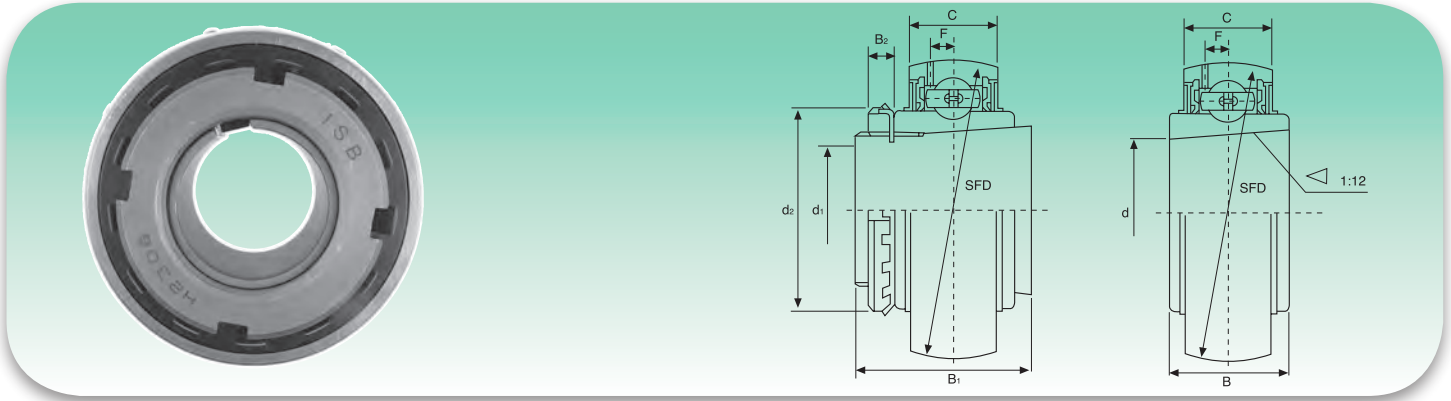
UK2 Serie normal - Standard duty

Tipo Type	Dimensiones - Dimensions										Coeficientes de carga (N) Load ratings (N)		Peso Weight kg
	d	D	B	C	d ₁	B ₁	B ₂	d ₂	F	Dinámica C Dynamic C	Estática C ₀ Static C ₀		
	mm/inch												
UK205+H2305	25	52	23	17	20	35	8	38	3,9	13300	7457	0,25	
UK205+HE2305	0,9843	2,0472	0,9055	0,6693	¾	1,378	0,315	1,496	0,154				
UK206+H2306	30	62	26	19	25	38	8	45	5,0	18525	10735	0,36	
UK206+HS2306	1,1811	2,4409	1,0236	0,7480	1	1,496	0,315	1,772	0,197				
UK207+H2307	35	72	29	20	30	43	9	52	5,7	24415	14630	0,57	
UK207+HS2307	1,3780	2,8346	1,1417	0,7874	11/8	1,693	0,354	2,047	0,224				
UK208+H2308	40	80	31	21	35	46	10	58	6,2	27645	16910	0,74	
UK208+HE2308	1,5748	3,1496	1,2205	0,8268	1¼	1,811	0,394	2,283	0,244				
UK209+H2309	45	85	31	22	40	50	11	65	6,4	32395	20235	0,83	
UK209+HA2309					17/16								
UK209+HE2309	1,7717	3,3465	1,2205	0,8661	1½	1,969	0,433	2,559	0,252				
UK209+HS2309					15/8								
UK210+H2310	50	90	32	24	45	55	12	70	6,5	33345	22135	0,97	
UK210+HS2310					15/8								
UK210+HA2310	1,9685	3,5433	1,2598	0,9449	111/16	2,165	0,472	2,756	0,256				
UK210+HE2310					1¾								
UK211+H2311	55	100	35	25	50	59	12	75	7,0	41230	27930	1,26	
UK211+HS2311					17/8								
UK211+HA2311	2,1654	3,9370	1,3780	0,9843	115/16	2,323	0,472	2,953	0,276				
UK211+HE2311					2								
UK212+H2312	60	110	38	27	55	62	13	80	7,6	49780	34390	1,59	
UK212+HS2312	2,3622	4,3307	1,4961	1,0630	21/8	2,441	0,512	3,150	0,299				
UK213+H2313	65	120	40	28	60	65	14	85	8,5	54340	38095	1,76	
UK213+HA2313					23/16								
UK213+HE2313	2,5591	4,7244	1,5748	1,1024	2¼	2,559	0,551	3,346	0,335				
UK213+HS2313					23/8								
UK215+H2315	75	130	44	30	65	73	15	98	9,2	64030	45885	2,32	
UK215+HA2315					27/16								
UK215+HE2315	2,9528	5,1181	1,7323	1,1811	2½	2,874	0,591	3,858	0,362				
UK216+H2316	80	140	45	32	70	78	17	105	9,5	69065	50350	3,06	
UK216+HA2316					211/16								
UK216+HE2316	3,1496	5,5118	1,7717	1,2598	2¾	3,071	0,669	4,134	0,374				
UK217+H2317	85	150	46	34	75	82	18	110	10,2	79800	58805	3,88	
UK217+HA2317					215/16								
UK217+HE2317	3,3465	5,9055	1,8110	1,3386	3	3,228	0,709	4,331	0,402				
UK218+H2318	90	160	47	36	80	86	18	120	11,2	91295	67925	4,74	
UK218+HA2318	3,5433	6,2992	1,8504	1,4173	33/16	3,386	0,709	4,724	0,441				

Disponible en acero inox AISI 440C - Available stainless steel AISI 440C

Manguitos HA; HE; HS con rosca en pulgadas - Inch dimension adapter sleeves HA; HE; HS

UKX Serie media - Medium duty

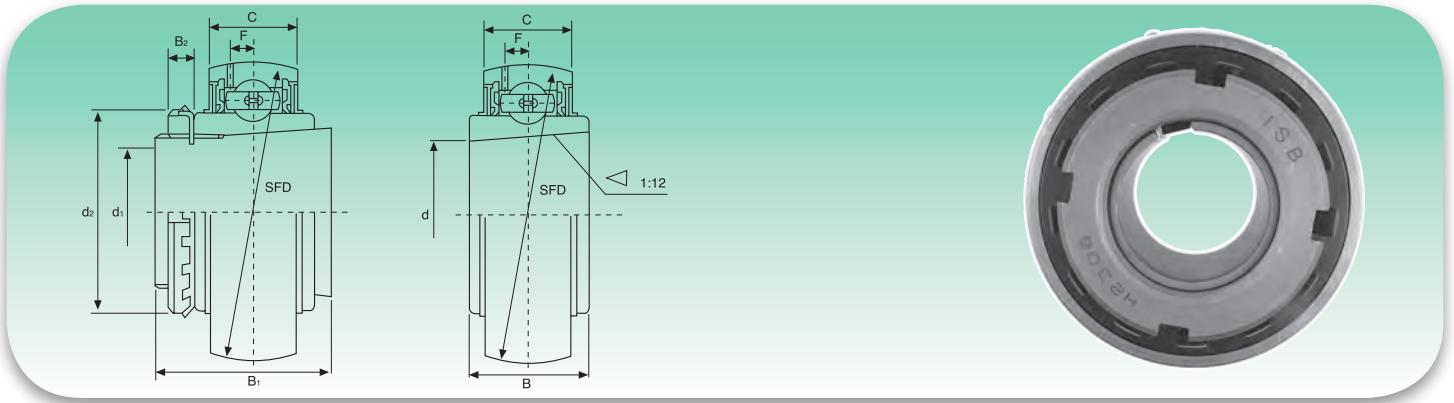

Tipo Type	Dimensiones - Dimensions									Coeficientes de carga (N) Load ratings (N)		Peso Weight kg
	d	D	B	C	d ₁	B ₁	B ₂	d ₂	F	Dinámica C Dynamic C	Estática C ₀ Static C ₀	
	mm/inch											
UKX05+H2305	25	62	26	19	20	35	8	38	5	18525	10735	0,37
UKX05+HE2305	0,9845	2,4409	1,0236	0,7480	¾	1,378	0,315	1,496	0,197			
UKX06+H2306	30	72	29	20	25	38	8	45	5,7	24415	14630	0,59
UKX06+HS2306	1,1811	2,8346	1,1417	0,7874	7/8	1,496	0,315	1,771	0,244			
UKX06+HE2306					1							
UKX07+H2307	35	80	31	21	30	43	9	52	6,2	27645	18910	0,75
UKX07+HS2307	1,3780	3,1496	1,2205	0,8268	11/8	1,693	0,354	2,047	0,244			
UKX08+H2308	40	85	31	22	35	46	10	58	6,4	32395	20235	0,86
UKX08+HE2308	1,5748	3,3465	1,2205	0,8661	1¼	1,811	0,394	2,284	0,252			
UKX08+HS2308					13/8							
UKX09+H2309	45	90	32	24	40	50	11	65	6,5	33345	22135	0,96
UKX09+HA2309	1,7717	3,5433	1,2598	0,9449	17/16	1,969	0,433	2,559	0,256			
UKX09+HE2309					1½							
UKX09+HS2309					15/8							
UKX10+H2310	50	100	35	25	45	55	12	70	7,0	41230	27930	1,34
UKX10+HS2310	1,9685	3,9370	1,3780	0,6843	15/8	2,165	0,472	2,756	0,726			
UKX10+HA2310					111/16							
UKX10+HE2310					1¾							
UKX11+H2311	55	100	38	27	50	59	12	75	7,6	49780	34390	1,67
UKX11+HS2311	2,1654	4,3307	1,496	1,0630	17/8	2,323	0,472	2,953	0,299			
UKX11+HA2311					115/16							
UKX11+HE2311					2							
UKX12+H2312	60	120	40	28	55	62	13	80	8,5	54340	38095	1,84
UKX12+HS2312	2,3622	4,7244	1,5748	1,1024	21/8	2,441	0,512	3,150	0,335			
UKX13+H2313	65	125	40	29	60	65	14	85	8,9	59090	41895	2,15
UKX13+HA2313	2,5591	4,9213	1,5748	1,1417	23/16	2,559	0,551	3,346	0,350			
UKX13+HE2313					2¼							
UKX13+HS2313					23/8							
UKX15+H2315	75	140	45	32	65	73	15	98	9,5	69065	50350	3,05
UKX15+HA2315	2,9528	5,5118	1,7717	1,2598	27/16	2,874	0,591	3,858	0,374			
UKX15+HS2315					2½							
UKX16+H2316	80	150	46	34	70	78	17	105	10,2	79800	58805	3,95
UKX16+HA2316	3,1496	5,9055	1,811	1,3386	211/16	3,071	0,669	4,134	0,402			
UKX16+HS2316					2¾							
UKX17+H2317	85	160	47	36	75	82	18	110	11,2	91295	67925	4,83
UKX17+HA2317	3,3465	6,2992	1,8504	1,4173	215/16	3,228	0,709	4,331	0,441			
UKX17+HE2317					3							
UKX18+H2318	90	170	52	39	80	86	18	120	12,5	103550	77805	5,45
UKX18+HA2318	3,5433	6,6929	1,9685	1,5354	33/16	3,386	0,709	4,724	0,492			

Manguitos HA; HE; HS con rosca en pulgadas - Inch dimension adapter sleeves HA; HE; HS

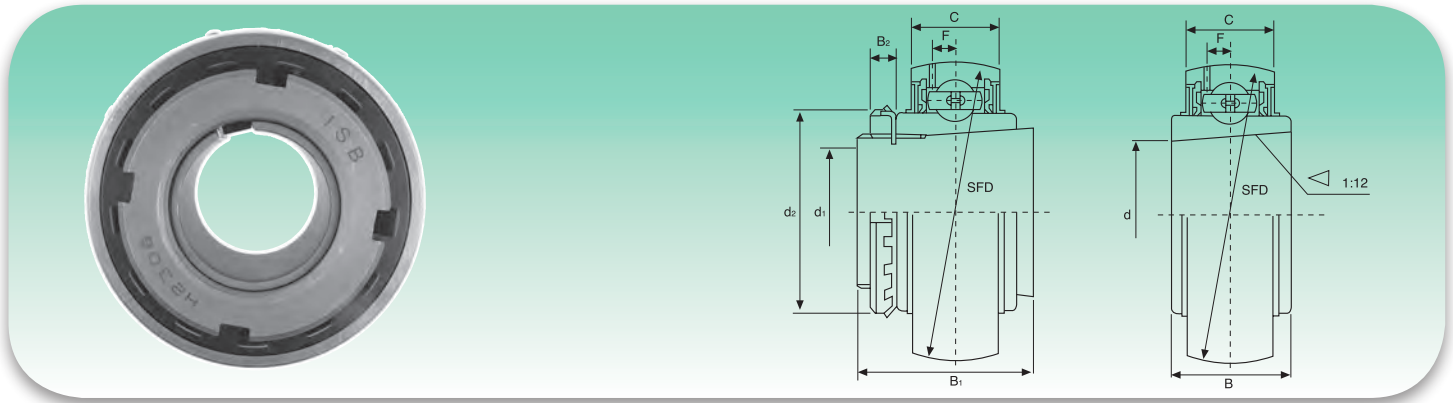
UK3 Serie pesada - Heavy duty

Tipo Type	Dimensiones - Dimensions									Coeficientes de carga (N) Load ratings (N)		Peso Weight kg
	d	D	B	C	d ₁	B ₁	B ₂	d ₂	F	Dinámica C Dynamic C	Estática C ₀ Static C ₀	
	mm/inch											
UK305+H2305	25	62	26	20	20	35	8	38	5,0	20140	10355	0,48
UC305+HE2305	0,9843	2,4409	1,0236	0,7874	¾	1,378	0,315	1,496	0,197			
UK306+H2306	30	72	29	23	25	38	8	45	5,9	25365	14250	0,59
UK306+HS2306	1,1811	2,8346	1,1417	0,9055	7/8	1,496	0,315	1,772	0,232			
UK306+HE2306					1							
UK307+H2307	35	80	33	25	30	43	9	52	6,8	31730	18335	0,76
UK307+HS2307	1,3780	3,1496	1,2992	0,9843	11/8	1,693	0,354	2,047	0,268			
UK308+H2308	40	90	34	27	35	46	10	58	7,4	38665	22800	1,07
UK308+HE2308	1,5748	3,5433	1,3386	1,0630	1¼	1,811	0,394	2,283	0,291			
UK308+HS2308					13/8							
UK309+H2309	45	100	37	29	40	50	11	65	7,4	46455	28025	1,31
UK309+HA2309	1,7717	3,9370	1,4567	1,1417	17/16	1,969	0,433	2,559	0,291			
UK309+HE2309					1½							
UK309+HS2309					15/8							
UK310+H2310	50	110	41	32	45	55	12	70	8,1	58900	36385	1,70
UK310+HS2310	1,9685	4,3307	1,6142	1,2598	15/8	2,165	0,472	2,756	0,319			
UK310+HA2310					111/16							
UK310+HE2310					1¾							
UK311+H2311	55	120	44	34	50	59	12	75	8,5	68020	42750	2,06
UK311+HS2311	2,1654	4,7244	1,7323	1,3386	17/8	2,323	0,472	2,953	0,335			
UK311+HA2311					115/16							
UK311+HE2311					2							
UK312+H2312	60	130	47	36	55	62	13	80	9	77805	49590	2,58
UK312+HS2312	2,3622	5,1181	1,8504	1,4173	21/8	2,441	0,512	3,150	0,354			
UK313+H2313	65	140	49	39	60	65	14	85	10,1	88065	56905	3,07
UK313+HA2313	2,5591	5,5118	1,9291	1,5354	23/16	2,559	0,551	3,346	0,398			
UK313+HE2313					2¼							
UK313+HS2313					23/8							
UK315+H2315	75	160	55	43	65	73	15	98	11	107350	73340	4,82
UK315+HA2315	2,9528	6,2992	2,1654	1,6929	27/16	2,874	0,591	3,858	0,433			
UK315+HE2315					2½							
UK316+H2316					80					170	58	45
UK316+HA2316	3,1496	6,6929	2,2835	1,7717	211/16	3,071	0,669	4,134	0,449			
UK316+HE2316					2¾							
UK317+H2317					85					180	60	47
UK317+HA2317	3,3465	7,0866	2,3622	1,8504	215/16	3,228	0,709	4,331	0,472			
UK317+HE2317					3							
UK318+H2318					90					190	64	49
UK318+HA2318	3,5433	7,4803	2,5197	1,9291	33/16	3,386	0,709	4,724	0,484			

Manguitos HA; HE; HS con rosca en pulgadas - Inch dimension adapter sleeves HA; HE; HS

SER2 Serie normal - Standard duty

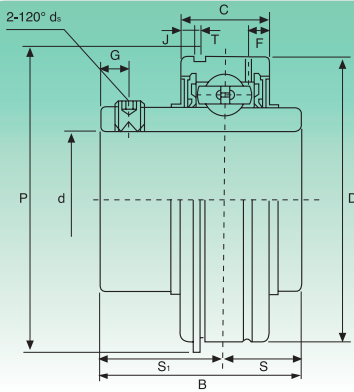

Sufijo UNF: Medidas en pulgadas de los pasadores de fijación
UNF suffix: inch sizes set screws

Tipo Type	Dimensiones - Dimensions												Coeficientes de carga (N) Load ratings (N)		Peso Weight kg
	d	D	B	C	S	S ₁	T	F	J	P	G	d _s	Dinámica C Dynamic C	Estática C ₀ Static C ₀	
	mm/inch														
SER204	20	47	31	15,9	10,3	20,7	1,12	3,8	2,46	52,7	4,8	M6x1	9880	6200	0,21
SER204-12	¾	1,8504	1,2205	0,6260	0,406	0,815	0,044	0,150	0,097	2,075	0,189	¼-28UNF			
SER205	25	52	34,9	19	13,1	21,8	1,12	5,2	2,46	57,9	5	M6x1	10780	6980	0,27
SER205-13	13/16	2,0472	1,3740	0,7480	0,516	0,858	0,044	0,205	0,097	2,280	0,197	¼-28UNF			
SER205-14	7/8														
SER205-15	15/16														
SER205-16	1														
SER206	30												62	38,1	22,2
SER206-17	11/16	2,4409	1,5000	0,8740	0,626	0,874	0,067	0,220	0,129	2,665	0,197	¼-28UNF			
SER206-18	11/8														
SER206-19	13/16														
SER206-20	1¼														
SER207	35												72	42,9	23,8
SER207-20	1¼	2,8346	1,6890	0,9370	0,689	1,000	0,067	0,220	0,129	3,094	0,264	5/16-24UNF			
SER207-21	15/16														
SER207-22	13/8														
SER207-23	17/16														
SER208	40												80	49,2	27,8
SER208-24	1½	3,1496	1,9370	1,0945	0,748	1,189	0,067	0,252	0,129	3,409	0,315	5/16-24UNF			
SER208-25	19/16														
SER209	45												85	49,2	27,8
SER209-26	15/8	3,3465	1,9370	1,0945	0,748	1,189	0,067	0,252	0,129	3,606	0,315	5/16-24UNF			
SER209-27	111/16														
SER209-28	1¾														
SER210	50												90	51,6	28,6
SER210-29	113/16	3,5433	2,0315	1,1260	0,748	1,283	0,097	0,295	0,129	3,799	0,394	3/8-24UNF			
SER210-30	17/8														
SER210-31	115/16														
SER210-32	2														
SER211	55												100	55,6	30,2
SER211-32	2	3,9370	2,1890	1,1890	0,874	1,315	0,097	0,295	0,129	4,193	0,394	3/8-24UNF			
SER211-33	21/16														
SER211-34	21/8														
SER211-35	23/16														
SER212	60												110	65,1	31,8
SER212-36	2¼	4,3307	2,5630	1,2520	1,000	1,563	0,097	0,295	0,129	4,591	0,394	3/8-24UNF			
SER212-37	25/16														
SER212-38	23/8														
SER212-39	27/16														

SA2 Serie ligera - Light duty

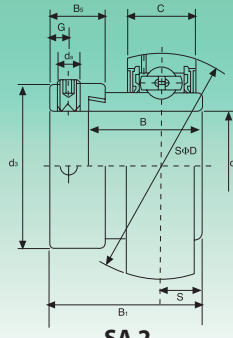

Sufijo UNF: Medidas en pulgadas de los pasadores de fijación
UNF suffix: inch sizes set screws

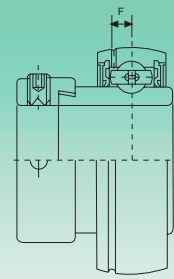

SA 2
aro exterior esférico
outer spherical ring

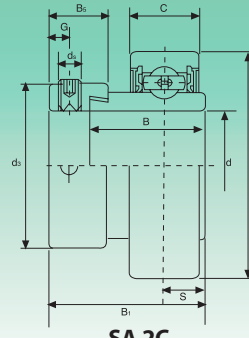

SA 2S
aro exterior esférico,
con ranura de lubricación
outer spherical ring,
with relubrication groove



SA 2C
aro exterior cilíndrico
outer cylindrical ring

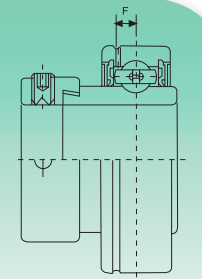

SA 2CS
aro exterior cilíndrico,
con alojamiento para anillos
seeger
outer cylindrical ring,
with groove for snap ring

Tipo Type	Dimensiones - Dimensions											Coeficientes de carga (N) Load ratings (N)		Peso Weight kg
	d	D	B ₁	B	C	S	d _s	G	B _s	d _s	F	Dinámica C Dynamic C	Estática C ₀ Static C ₀	
	mm/inch													
SA201	12	40	28,6	19,1	12	6,5	M6x1	4,8	13,5	28,6	3,7	9200	4480	0,12
SA201-8	¾	1,5748	1,126	0,7520	0,4724	0,256	¼-28UNF	0,189	0,531	1,126	0,146			
SA202	15	40	28,6	19,1	12	6,5	M6x1	4,8	13,5	28,6	3,7	9200	4480	0,10
SA202-9	9/16	1,5748	1,126	0,7520	0,4724	0,256	¼-28UNF	0,189	0,531	1,126	0,146			
SA202-10	5/8													
SA203	17	40	28,6	19,1	12	6,5	M6x1	4,8	13,5	28,6	3,7	9200	4480	0,09
SA203-11	11/16	1,5748	1,126	0,7520	0,4724	0,256	¼-28UNF	0,189	0,531	1,126	0,146			
SA204	20	47	31	21,5	14	7,5	M6x1	4,8	13,5	33,3	3,7	12200	6300	0,16
SA204-12	¾	1,8504	1,220	0,8465	0,5512	0,295	¼-28UNF	0,189	0,531	1,311	0,146			
SA205	25	52	31	21,5	15	7,5	M6x1	4,8	13,5	38,1	3,9	13300	7460	0,20
SA205-13	13/16	2,0472	1,220	0,8465	0,5906	0,295	¼-28UNF	0,189	0,531	1,500	0,154			
SA205-14	7/8													
SA205-15	15/16													
SA205-16	1													
SA206	30													
SA206-17	11/16	2,4409	1,406	0,9370	0,6299	0,354	5/16-28UNF	0,236	0,626	1,752	0,197			
SA206-18	11/8													
SA206-19	13/16													
SA206-20	1¼													
SA207	35	72	38,9	25,4	17	9,5	M8x1	6,8	17,5	55,6	5,7	24500	14600	0,42
SA207-20	1¼	2,8346	1,531	1,000	0,6693	0,374	5/16-24UNF	0,268	0,689	2,189	0,224			
SA207-21	15/16													
SA207-22	13/8													
SA207-23	17/16													
SA208	40	80	43,7	30,2	18	11	M8x1	6,8	18,3	60,3	6,2	27700	17000	0,60
SA208-24	1½	3,1496	1,721	1,1890	0,7087	0,433	5/16-24UNF	0,268	0,720	2,374	0,244			
SA208-25	19/16													
SA209	45	85	43,7	30,2	19	11	M8x1	6,8	18,3	63,5	6,4	31100	24450	0,76
SA209-26	15/8	3,3465	1,721	1,1890	0,7480	0,433	5/16-24UNF	0,268	0,720	2,500	0,252			
SA209-27	111/16													
SA209-28	1¾													
SA210	50	50	43,7	30,2	20	11	M8x1	6,8	18,3	69,9	6,5	35300	28160	0,91
SA210-29	113/16	3,5433	1,721	1,1890	0,7874	0,433	5/16-24UNF	0,268	0,720	2,752	0,256			
SA210-30	17/8													
SA210-31	115/16													
SA210-32	2													
SA211	55	100	48,4	32,5	21	12	M8x1	8	20,7	76,2	7,0	38100	30000	1,26
SA211-32	2	3,9370	1,906	1,2795	0,8268	0,472	5/16-24UNF	0,315	0,815	3,000	0,276			
SA211-33	21/16													
SA211-34	21/8													
SA211-35	23/16													
SA212	60	110	53,1	37,2	22	13,5	M10x1	8	22,3	84,2	7,6	41500	32730	1,70
SA212-36	2¼	4,3307	2,091	1,4646	0,8661	0,532	3/8-24UNF	0,315	0,878	3,315	0,299			
SA212-37	25/16													
SA212-38	23/8													
SA212-39	27/16													

Disponible en acero inox AISI 440C - Available stainless steel AISI 440C

SB-RB2 Serie ligera - Light duty

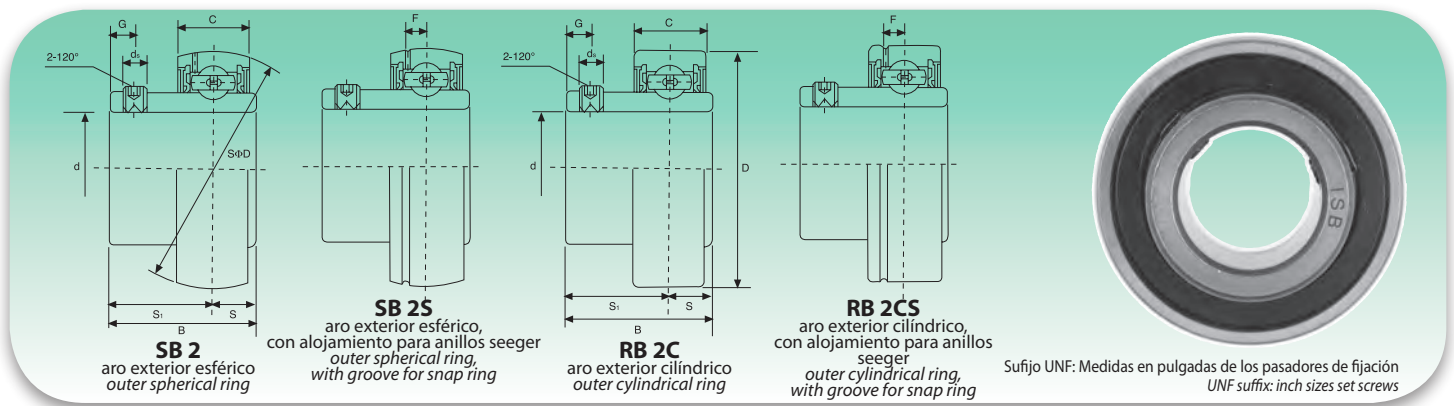

Tipo Type	Dimensiones - Dimensions									Coeficientes de carga (N) Load ratings (N)		Peso Weight kg
	d	D	B	C	S	S ₁	d _s	G	F	Dinámica C Dynamic C	Estática C ₀ Static C ₀	
	mm/inch											
SB-RB201	12	40	22	12	6	16	M5x0,8	4,5	3,7	9200	4480	0,10
SB-RB201-8	3/4	1,5748	0,8661	0,4724	0,236	0,630	10-32UNF	0,177	0,146			
SB-RB202	15	40	22	12	6	16	M5x0,8	4,5	3,7	9200	4480	0,10
SB-RB202-9	9/16	1,5748	0,8661	0,4724	0,236	0,630	10-32UNF	0,177	0,146			
SB-RB202-10	5/8											
SB-RB203	17	40	22	12	6	16	M5x0,8	4,5	3,7	9200	4480	0,09
SB-RB203-11	11/16	1,5748	0,7520	0,4724	0,256	1/4-28UNF	0,189	0,531	0,146			
SB-RB204	20	47	25	14	7	18	M6x1	4,5	3,7	12200	6300	0,13
SB-RB204-12	3/4	1,8504	0,9843	0,5512	0,276	0,709	1/4-28UNF	0,177	0,146			
SB-RB205	25	52	27	15	7,5	19,5	M6x1	5,5	3,9	13300	7460	0,16
SB-RB205-13	13/16	2,0472	1,0630	0,5906	0,295	0,768	1/4-28UNF	0,217	0,154			
SB-RB205-14	7/8											
SB-RB205-15	15/16											
SB-RB205-16	1											
SB-RB206	30	62	30	16	8	22	M6x1	6	5,0	18500	10800	0,25
SB-RB206-17	11/16	2,4409	1,1811	0,6299	0,315	0,866	1/4-28UNF	0,236	0,197			
SB-RB206-18	11/8											
SB-RB206-19	13/16											
SB-RB206-20	1 1/4											
SB-RB207	35	72	32	17	8,5	23,5	M8x1	6,5	5,7	24500	14600	0,38
SB-RB207-20	1 1/4	2,8346	1,2598	0,6693	0,335	0,925	5/16-24UNF	0,256	0,224			
SB-RB207-21	15/16											
SB-RB207-22	13/8											
SB-RB207-23	17/16											
SB-RB208	40	80	34	18	9	25	M8x1	7	6,2	27700	17000	0,60
SB-RB208-24	1 1/2	3,1496	1,3386	0,7087	0,354	0,984	5/16-24UNF	0,276	0,244			
SB-RB208-25	19/16											
SB-RB209	45	85	41,2	19	10,2	31	M8x1	8,2	6,4	31100	24450	0,8
SB-RB209-26	15/8	3,3465	1,6220	0,7480	0,402	1,220	5/16-24UNF	0,323	0,252			
SB-RB209-27	111/16											
SB-RB209-28	1 3/4											
SB-RB210	50	90	43,5	20	10,9	32,6	M10x1	9,2	6,5	35300	28160	0,8
SB-RB210-29	113/16	3,5433	1,7126	0,7874	0,429	1,283	3/8-24UNF	0,362	0,256			
SB-RB210-30	17/8											
SB-RB210-31	115/16											
SB-RB210-32	2											
SB-RB211	55	100	45,3	21	11,8	33,5	M10x1	9,8	7,0	38100	30000	1,1
SB-RB211-32	2	3,9370	1,7835	0,8268	0,465	1,319	3/8-24UNF	0,386	0,276			
SB-RB211-33	21/16											
SB-RB211-34	21/8											
SB-RB211-35	23/16											
SB-RB212	60	110	53,7	22	14,9	38,8	M10x1	9,8	7,6	41500	32730	1,3
SB-RB212-36	2 1/4	4,3307	2,1142	0,8661	0,587	1,528	3/8-24UNF	0,386	0,299			
SB-RB212-37	25/16											
SB-RB212-38	23/8											
SB-RB212-39	27/16											

Disponible en acero inox AISI 440C - Available stainless steel AISI 440C

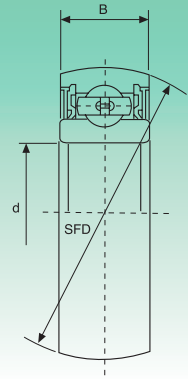

Tipo Type	Dimensiones - Dimensions			Coeficientes de carga (N) Load ratings (N)		Peso Weight kg
	d	D	B	Dinámica C Dynamic C	Estática C ₀ Static C ₀	
	mm/inch					
CB200	10	30	9	3750	2150	0,030
CB200	0,3937	1,1811	0,3543			
CB201	12	32	10	4500	2500	0,035
CB201	0,4724	1,2598	0,3937			
CB202	15	35	11	5650	3300	0,040
CB202	0,5906	1,3780	0,4331			
CB203	17	40	12	7000	4480	0,06
CB203	0,6693	1,5748	0,4724			
CB204	20	47	14	9880	6200	0,10
CB204	0,7874	1,8504	0,5512			
CB205	25	52	15	10780	6980	0,13
CB205	0,9843	2,0472	0,5906			
CB206	30	62	16	14970	10040	0,20
CB206	1,1811	2,4409	0,6299			
CB207	35	72	17	19750	13670	0,29
CB207	1,3780	2,8346	0,6693			
CB208	40	80	18	22710	15940	0,37
CB208	1,5748	3,1496	0,7087			
CB209	45	85	19	24360	17710	0,46
CB209	1,7717	3,3465	0,7480			
CB210	50	90	20	26980	19840	0,57
CB210	1,9685	3,5433	0,7874			
CB211	55	100	21	28500	21850	0,62
CB211	2,1654	3,9370	0,8268			
CB212	60	110	22	31700	24500	0,80
CB212	2,3622	4,3307	0,8661			

Equivalente serie 62.. bombeado ISB® - Equivalent 62.. spherical ISB®

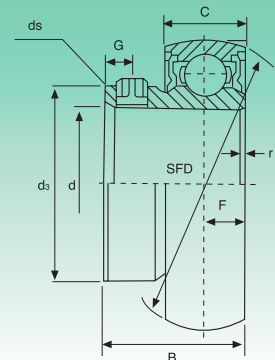

Tipo Type	Dimensiones - Dimensions									Coeficientes de carga (N) Load ratings (N)		Peso Weight kg
	d	D	B	C	ds	F	G	r	ds	Dinámica C Dynamic C	Estática C ₀ Static C ₀	
	mm/inch											
U0000	10	26	14	8	14,75	4	3	0,5	M3	470	200	0,023
U0000	0,3937	1,024	0,5512	0,3150	0,5807	1,1575	0,1181	0,0197				
U0001	12	28	14,5	8	17,35	4	3	0,5	M3	520	245	0,027
U0001	0,4724	1,1024	0,5709	0,3150	0,6831	1,1575	0,1181	0,0197				
U0002	15	32	16,5	9	20,02	4,5	3,5	0,5	M4	570	290	0,045
U0002	0,5906	1,2598	0,6496	0,3543	0,7882	0,1772	0,1378	0,0197				
U0003	17	35	17,5	10	23,10	5	3,5	0,5	M4	610	335	0,050
U0003	0,6693	1,3780	0,6890	0,3937	0,9094	0,1969	0,1378	0,0197				
U0004	20	42	21	12	27,00	6	4	1	M5	955	515	0,086
U0004	0,7874	1,6535	0,8268	0,4724	1,0630	0,2362	1,1575	0,0394				
U0005	25	47	22,5	12	31,70	6	4,5	1	M5	1030	595	0,100
U0005	0,9843	1,8504	0,8858	0,4724	1,2480	0,2362	0,1772	0,0394				
U0006	30	55	24,5	13	38,00	6,5	5	1,5	M5	1350	845	0,145
U0006	1,1811	2,1654	0,9646	0,5118	1,4961	0,2559	0,1969	0,0591				

Disponible bajo demanda en acero inox: AISI 440C - Available under request stainless steel: AISI 440C

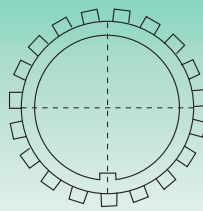
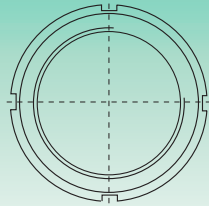
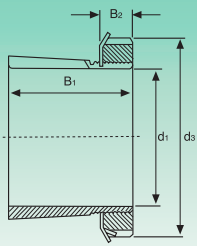

Tipo Type	Dimensiones - Dimensions				Manguito Sleeve	Tuerca de bloqueo Lock nut	Arandela Washer	Rodamiento Bearing			Peso Weight			
	d ₁	B ₁	B ₂	d ₃				A...	KM	MB		Serie normal Normal duty	Serie media Medium duty	Serie pesada Heavy duty
	mm/inch													
H 2305	20	35	8	38	A 2305X	KM 05	MB 05	UK 205	UK X05	UK 305	0,087			
HE 2305	¾	1,3780	0,3150	1,4961	AE 2305X									
H 2306	25	38	8	45	A 2306X	KM 06	MB 06	UK 206	UK X06	UK 306	0,126			
HS 2306	7/8				AS 2306X									
HA 2306	15/16	1,4961	0,3150	1,7717	AA 2306X									
HE 2306	1				AE 2306X									
H 2307	30	43	9	52	A 2307X	KM 07	MB 07	UK 207	UK X07	UK 307	0,165			
HS 2307	1 1/8				AS 2307X									
HA 2307	13/16	1,6929	0,3543	2,0472	AA 2307X									
H 2308	35	46	10	58	A 2308X	KM 08	MB 08	UK 208	UK X08	UK 308	0,224			
HE 2308	1 ¼				AE 2308X									
HS 2308	13/8	1,8110	0,3937	2,2835	AS 2308X									
H 2309	40	50	11	65	A 2309X	KM 09	MB 09	UK 209	UK X09	UK 309	0,280			
HA 2309	17/16				AA 2309X									
HE 2309	1 ½	1,9685	0,4331	2,5591	AE 2309X									
HS 2309	15/8				AS 2309X									
H 2310	45	55	12	70	A 2310X	KM 10	MB 10	UK 210	UK X10	UK 310	0,362			
HA 2310	1 11/16				AA 2310X									
HE 2310	1 ¾	2,1654	0,4724	2,7559	AE 2310X									
H 2311	50	59	12	75	A 2311X	KM 11	MB 11	UK 211	UK X11	UK 311	0,420			
HS 2311	17/8				AS 2311X									
HA 2311	1 15/16	2,3228	0,4724	2,9528	AA 2311X									
HE 2311	2				AE 2311X									
H 2312	55	62	13	80	A 2312X	KM 12	MB 12	UK 212	UK X12	UK 312	0,480			
HS 2312	2 1/8	2,4409	0,5118	3,1496	AS 2312X									
H 2313	60	65	14	85	A 2313X	KM 13	MB 13	UK 213	UK X13	UK 313	0,556			
HA 2313	23/16				AA 2313X									
HE 2313	2 ¼	2,5591	0,5512	3,3465	AE 2313X									
HS 2313	23/8				AS 2313X									
H 2315	65	73	15	98	A 2315X	KM 15	MB 15	UK 215	UK X15	UK 315	1,05			
HE 2315	2 ½				AE 2315X									
HS 2315	25/8	2,8740	0,5906	3,8583	AS 2315X									
H 2316	70	78	17	105	A 2316X	KM 16	MB 16	UK 216	UK X16	UK 316	1,28			
HE 2316	2 ¾	3,0709	0,6693	4,1339	AE 2316X									
H 2317	75	82	18	110	A 2317X	KM 17	MB 17	UK 217	UK X17	UK 317	1,45			
HS 2317	27/8				AS 2317X									
HA 2317	2 15/16	3,2283	0,7087	4,3307	AA 2317X									
HE 2317	3				AE 2317X									
H 2318	80	86	18	120	A 2318X	KM 18	MB 18	UK 218	UK X18	UK 318	1,70			
HA 2318	33/16	3,3858	0,7087	4,7244	AA 2318X									
H 2319	85	90	19	125	A 2319X	KM 19	MB 19	-	-	UK 319	1,94			
HE 2319	3 ¼	3,5433	0,7480	4,9213	AE 2319X									
H 2320	90	97	20	130	A 2320X	KM 20	MB 20	-	UK X20	UK 320	2,15			
HE 2320	3 ½	3,8189	0,7874	5,1181	AE 2320X									
H 2322	100	105	21	145	A 2322X	KM 22	MB 22	-	-	UK 322	2,74			
HE 2322	4	4,1339	0,8268	5,7087	AE 2322X									
H 2324	110	112	22	155	A 2324X	KM 24	MB 24	-	-	UK 324	3,20			
HA 2324	47/16	4,4094	0,8661	6,1024	AA 2324X									
H 2326	115	121	23	165	A 2326X	KM 26	MB 26	-	-	UK 326	4,60			
HE 2326	4 ½	4,7638	0,9055	6,4961	AE 2326X									
H 2328	125	131	24	180	A 2328X	KM 28	MB 28	-	-	UK 328	5,52			
HA 2328	4 15/16				AA 2328X									
HE 2328	5 1/8	5,1575	0,9449	7,0866	AE 2328X									



SNG 500 - SNG 600



**SNU 500 - SNU 600
SNA 500 - SNA 600**



**SN 500 - SN 600
SN 200 - SN 300**



SD 3100

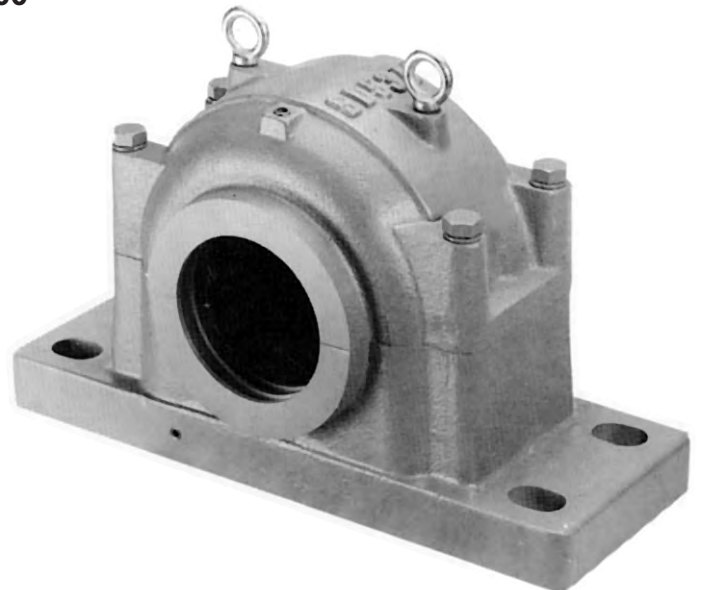

SD 3000

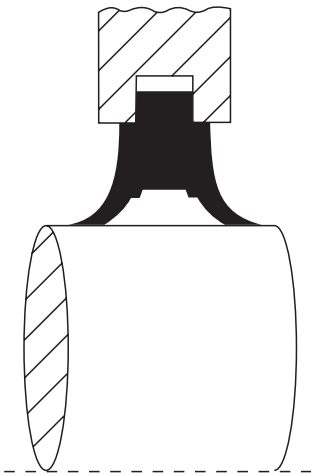

Obtención de poliuretano "TSNG" para: SNG-SNU
 "TSNG" polyurethan seal for: SNG-SNU

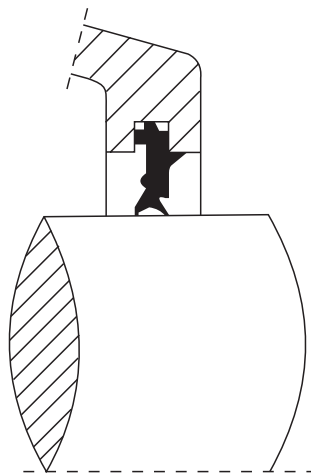

Obtención de caucho "TSNU" para: SNG-SNU
 "TSNU" rubber seal for: SNG-SNU

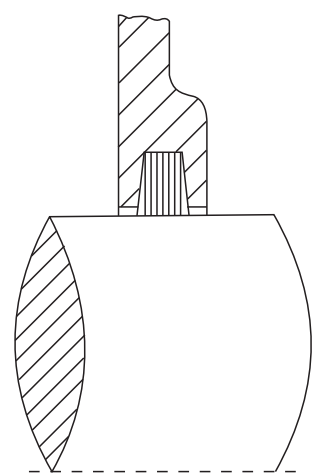

Obtención de fieltro "TSNC" para: SNG-SNU
 "TSNC" felt seal for: SNG-SNU

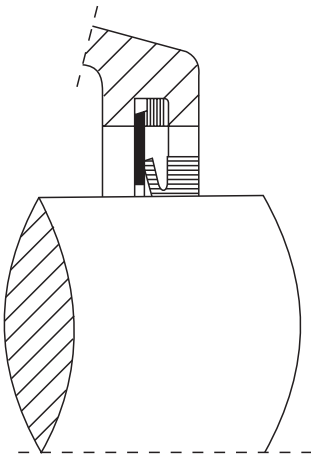

Obtención de anillo en v "TSNA" para: SNG-SNU
 "TSNA" v-ring seal for: SNG-SNU

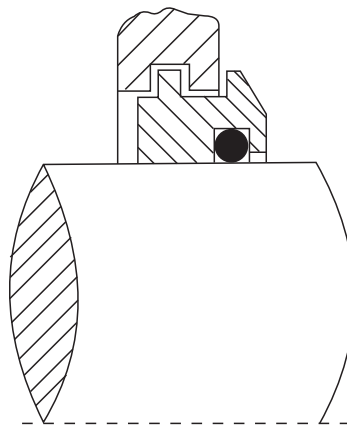

Obtención de laberinto "TSNS" para: SNG-SNU
 "TSNS" labyrinth seal for: SNG-SNU

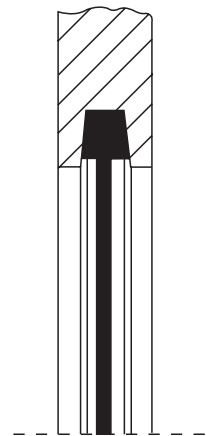

Tapa de cierre "A" para: SNG-SNU-SN
 "A" end cover for: SNG-SNU-SN

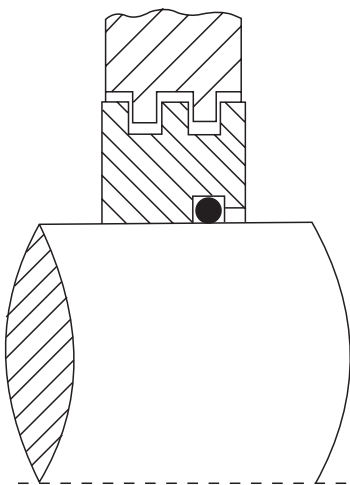

Obtención de laberinto "TS" para: SN-SD
 "TS" labyrinth seal for: SN-SD

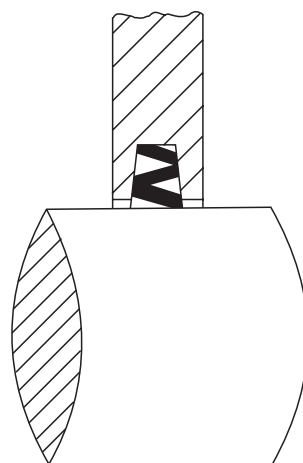

Obtención de NBR "ZF" para: SN
 "ZF" NBR seals for: SN

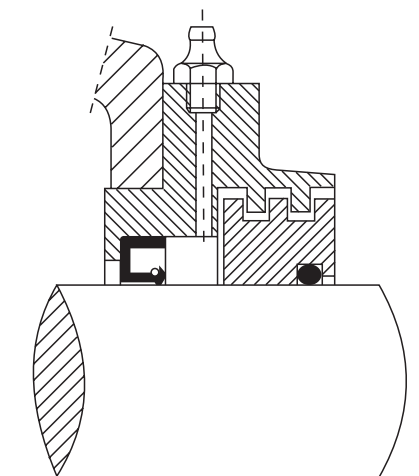

Obtención de taconite "TAC" para: SN-SD
 "TAC" taconite cover for: SN-SD

A
MATERIALES - MATERIALS:
1
CUERPO - HOUSING:

Material Material	Carga de rotura Tensile strength kgf/mm ²	Carga de rotura Yield strength kgf/mm ²	Alargamiento Elongation	Código Jis Jis code	Código USA U.S. code
FUNDICIÓN CAST IRON	20	-	-	G 5501 (FC 200)	ASTM A 48 GRADO/GRADE 35
ACERO DUCTIL DUCTILE IRON (S. G.)	45	30	10%	G 5502 (FCD 450)	ASTM A 536 GRADO/GRADE 65-45-12

2
ACCESORIOS - ACCESSORIES:

Dispositivos de obturación Sealing arrangements	Sigla Ref.	Para For	Materiales Materials
OBTURACIÓN DE POLIURE- TANO POLYURETHAN SEAL	TSNG	SNG-SNU	Poliuretano Polyurethan
OBTURACIÓN DE CAUCHO U-LOCK RUBBER SEAL	TSNU	SNG-SNU	CAUCHO Rubber
OBTURACIÓN DE FIELTRO FELT SEAL	TSNC	SNG-SNU	Fieltro Felt
OBTURACIÓN DE ANILLO EN V V-RING SEAL	TSNA	SNG-SNU	NBR NBR
OBTURACIÓN DE LABERINTO LABYRINTH SEAL	TSNS	SNG-SNU	Fundición Cast iron
TAPA DE CIERRE END COVER	A	SNG-SNU-SN	NBR y chapa de acero NBR and Carbon steel plate
OBTURACIÓN DE LABERINTO LABYRINTH SEAL	TS	SN-SD	Fundición Cast iron
OBTURACIÓN DE TACONITE TACONITE COVER TAC	TAC	SD	Fundición Cast iron

3
TOLERANCIAS - TOLERANCES:

(mm.)

	Dimensiones - Dimensions	Tolerancias - Tolerances
		1-100
TOLERANCIA DE LA FUNDICION CASTING TOLERANCE	100-200	± 2,0
	200-400	± 3,0
	400-800	± 4,0
	800-1600	± 5,0

TOLERANCIAS DE MECANIZADO - MACHINE TOLERANCES

1

DIÁMETRO DEL AGUJERO (D) - BORE DIAMETER (D)

(µm)

Diámetro del orificio (mm) Bore diameter (mm)	G7	H7	H8	J7
10-18	+24 +26	-18 -0	+27 -0	+10 -8
18-30	+28 +7	+21 -0	+33 -0	+12 -9
30-50	+34 +9	+25 -0	+39 -0	+14 -11
50-80	+40 +10	+30 -0	+46 -0	+18 -12
80-120	+42 +12	+35 -0	+54 -0	+22 -13
120-180	+54 +14	+40 -0	+63 -0	+26 -14
180-250	+61 +15	+46 -0	+72 -0	+30 -16
250-315	+69 +17	+52 -0	+81 -0	+36 -16
315-400	+75 +18	+57 -0	+89 -0	+39 -18
400-500	+83 +20	+63 -0	+97 -0	+43 -20
500-620	+92 +23	+69 -0	+104 -0	+46 -23

2

OTRAS TOLERANCIAS EXCEPTO AGUJERO (D) - OTHER TOLERANCES, EXCEPT BORE (D)

(µm)

Diámetro del orificio (mm) Bore diameter (mm)	js11	H12	H13	h12	h13
18-30	±65	+210 -0	+330 -0	+0 -210	+0 -330
30-50	±80	+250 -0	+390 -0	+0 -250	+0 -390
50-80	±95	+300 -0	+460 -0	+0 -300	+0 -460
80-120	±110	+350 -0	+540 -0	+0 -350	+0 -540
120-180	±125	+400 -0	+630 -0	+0 -400	+0 -630
180-250	±145	+460 -0	+720 -0	+0 -460	+0 -720
250-315	±160	+520 -0	+810 -0	+0 -520	+0 -810
315-400	±180	+570 -0	+890 -0	+0 -570	+0 -890

3

TOLERANCIAS SUGERIDAS PARA ALOJAMIENTO DEL RODAMIENTO - RECOMMENDED FITS OF BEARING HOUSING TOLERANCES

CUERPO DE SOPORTE ENTERO O PARTIDO SPLIT OR SOLID HOUSING	Condiciones de carga Load conditions		Ejemplo de referencia Reference example	Tolerancias Tolerances	Aro exterior Outer ring
	Sentido de la carga no determinante Direction of load indeterminate	Carga normal y ligera Normal and light load	Motores eléctricos, bombas Electric motors, pumps	J7	Posibilidad de desplazamiento Can be displaced
Carga del aro interior rotativo Rotating inner ring load	Cargas de todos los tipos Loads of a kinds	Aplicaciones generales de rodamientos y casquillos Bearings and bushes general applications	H7	Posibilidad de fácil desplazamiento Can easily be displaced	
Carga del aro interior rotativo Rotating inner ring load	Carga ligera y normal Normal and light load	Soportes Plummer blocks	H8	Posibilidad de fácil desplazamiento Can easily be displaced	
Carga del aro interior rotativo Rotating inner ring load	Incremento de la temperatura del aro interior a través del eje High temperature rise of inner ring through shaft	Secadoras para papel Paper dryers	J7	Posibilidad de fácil desplazamiento Can easily be displaced	

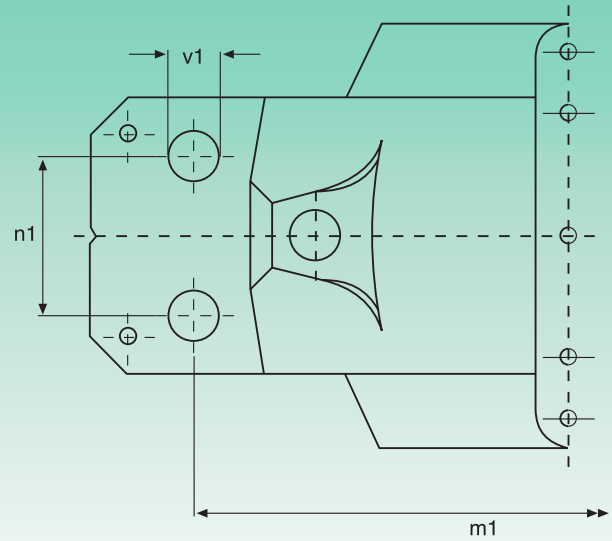
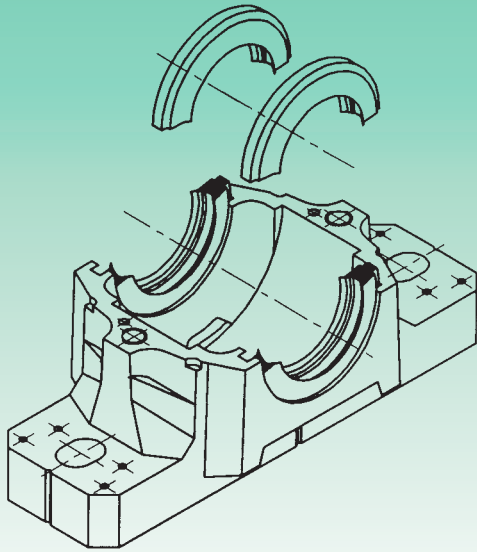

OBTURACIONES "TSNG" PARA EJES MÉTRICOS Y EN PULGADAS
 "TSNG" SEALS FIT BOTH METRIC & INCHES SHAFTS

DISPONIBLE PARA MONTAJE DE CUATRO AGUJEROS
 AVAILABLE FOR FOUR-BOLT MOUNTING

Tipo Type	m1	n1	v1	Bul. fij. Bolt Size	Obturación Seal	Diámetro eje Shaft diameter		Obturación Seal	Diámetro eje Shaft diameter			
						mm	inch		mm	inch		
SNG 507-606D	-	-	-	-	TSNG 507	30	1 1/8	13/16	TSNG 607	30	1 1/8	13/16
SNG 508-607D	160	34	11	M10	TSNG 508	35	15/16	13/8	TSNG 608	35	15/16	13/8
SNG 509D	160	34	11	M10	TSNG 509	40	1 1/2	19/16	TSNG 609	40	1 1/2	19/16
SNG 510-608D	160	34	11	M10	TSNG 510	45	111/16	1 3/4	TSNG 610	45	111/16	1 3/4
SNG 511-609D	200	40	14	M12	TSNG 511	50	115/16	2	TSNG 611	50	115/16	2
SNG 512-610D	200	40	14	M12	TSNG 512	55	21/8	23/16	TSNG 612	55	21/8	23/16
SNG 513-611D	220	48	14	M12	TSNG 513	60	2 1/4	25/16	TSNG 613	60	2 1/4	25/16
SNG 515-612D	220	48	14	M12	TSNG 515	65	27/16	2 1/2	TSNG 615	65	27/16	2 1/2
SNG 516-613D	252	52	18	M16	TSNG 516	70	211/16	2 3/4	TSNG 616	70	211/16	2 3/4
SNG 517D	252	52	18	M16	TSNG 517	75	215/16	3	TSNG 617	75	215/16	3
SNG 518-615D	280	58	18	M16	TSNG 518	80	33/16	3 1/4	TSNG 618	80	33/16	3 1/4
SNG 519-616D	280	58	18	M16	TSNG 519	85	35/16	33/8	TSNG 619	85	35/16	33/8
SNG 520-617D	300	66	18	M16	TSNG 520	90	37/16	3 1/2	TSNG 620	90	37/16	3 1/2
SNG 522-619D	320	74	18	M16	TSNG 522	100	315/16	4	-	-	-	-
SNG 524-620D	330	74	18	M16	TSNG 524	110	43/16	4 1/4	-	-	-	-
SNG 526D	370	80	22	M20	TSNG 526	115	47/16	4 1/2	-	-	-	-
SNG 528D	400	92	26	M24	TSNG 528	125	415/16	5	-	-	-	-
SNG 530D	430	100	26	M24	TSNG 530	135	53/16	5 1/4	-	-	-	-
SNG 532D	450	100	26	M24	TSNG 532	140	57/16	5 1/2	-	-	-	-

INTERCAMBIABLE CON SOPORTES SNH, SNU, SNA.
INTER-EXCHANGEABLE WITH PLUMMER BLOCKS SNH, SNU, SNA.

Posibilidad de selección para colocación engrasadores y aceitadores
Various choice of oil/grease locations

Punzonado para eventual aplicación de pernos de referencia
Dimples provider for locating pins if required

Múltiples zonas para la instalación de los sensores
Various sensor/monitor installing spaces

Cavidades previstas para desmontaje soporte
Gaps provider to help splitting the housings

Líneas de referencia centrales para facilitar la alineación en el montaje
Cross center lines for easy alignment in assembly

Base reforzada para cargas pesantes
Reinforced base for heavy load

Ocho posiciones seleccionadas para el drenaje
Eight location selected for drainage

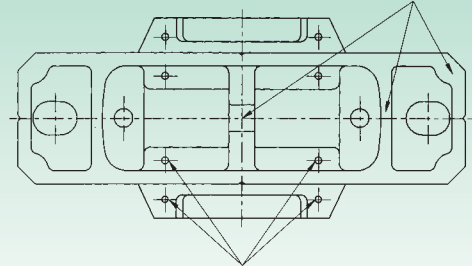
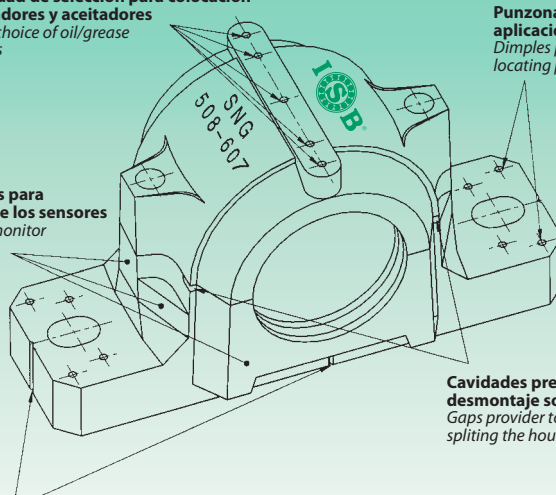

CARGAS DE ROTURA - BREAKING LOADS

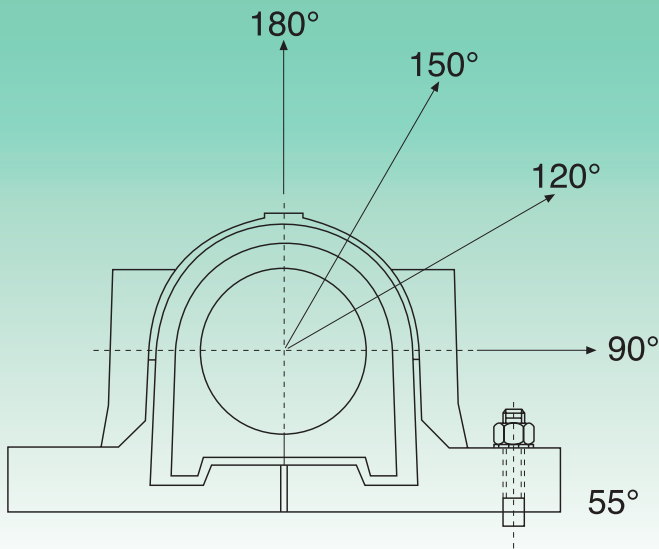

Tipo Type	Cargas de rotura - Breaking loads						
	P ₀	P ₅₅	P ₉₀	P ₁₂₀	P ₁₅₀	P ₁₆₀	P _{axial} axial
	kN						
SNG 205-505	100	155	95	70	60	80	52
SNG 206-305-506-605	130	170	100	80	65	85	55
SNG 207-507-606	140	190	115	85	80	95	60
SNG 208-307-508-607	150	215	130	95	85	110	70
SNG 209-509	160	230	140	100	90	115	75
SNG 210-510-608	170	265	155	120	110	130	85
SNG 211-511-609	190	275	170	125	115	140	90
SNG 212-512-610	210	300	180	130	120	150	100
SNG 213-513-611	270	340	205	150	130	170	110
SNG 215-515-612	290	410	250	185	160	205	135
SNG 216-516-613	350	430	260	190	175	215	140
SNG 217-517	370	480	290	205	190	240	155
SNG 218-518-615	430	550	340	250	215	275	180
SNG 519-616	-	580	350	260	230	290	190
SNG 520-617	-	620	370	280	250	310	200
SNG 522-619	-	680	410	310	275	340	220
SNG 524-620	-	790	470	350	320	400	260
SNG 526	-	900	540	410	360	450	295
SNG 528	-	1050	630	470	430	530	345
SNG 530	-	1200	730	540	480	600	390
SNG 532	-	1450	860	640	570	720	470

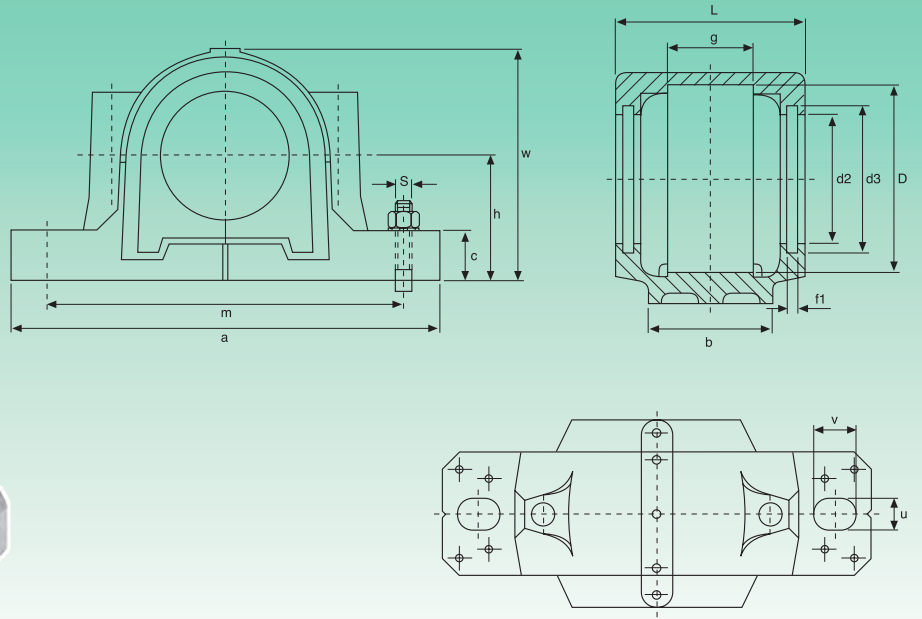

Tipo Type	Diámetro eje Shaft diameter		Dimensiones - Dimensions														Bul. fj. Bolt Size
			D H8	a	b	c	g H12	h js11	L	w	m	U	V	d2 H12	d3 H12	f1	
	mm	inch	mm/inch														S
SNG 505	20	¾	52	165	46	19	25	40	67	71	130	13	20	31,5	39,5	5	M10
SNG 506-605	25	15/16 1	62	185	52	22	32	50	77	87	150	13	22	36,5	44,5	5	M10
SNG 507-606	30	11/8 13/16	72	185	52	22	34	50	82	92	150	15	20	46,5	54,5	5	M12
SNG 508-607	35	15/16 13/8	80	205	60	25	39	60	85	106	170	15	20	51,5	59,5	5	M12
SNG 509	40	1½ 19/16	85	205	60	25	30	60	85	109	170	15	20	56,5	64,5	5	M12
SNG 510-608	45	11/16 1¾	90	205	60	25	41	60	90	112	170	15	20	62	70,5	5	M12
SNG 511-609	50	115/16 2	100	255	70	28	44	70	95	127	210	18	23	67	75,5	5	M16
SNG 512-610	55	21/8 23/16	110	255	70	30	48	70	105	133	210	18	23	72	80,5	5	M16
SNG 513-611	60	2¼ 25/16	120	275	80	30	51	80	110	148	230	18	24	77	85,5	5	M16
SNG 515-612	65	27/16 2½	130	280	80	30	56	80	115	154	230	18	26	87	95,5	5	M16
SNG 516-613	70	211/16 2¾	140	315	90	32	58	95	120	175	260	22	29	92,5	101	5	M20
SNG 517	75	215/16 3	150	320	90	32	61	95	125	181	260	22	30	97,5	106	5	M20
SNG 518-615	80	33/16 3¼	160	345	100	35	65	100	140	192	290	22	27	102,5	111	5	M20
SNG 519-616	85	35/16 33/8	170	345	100	35	68	112	145	209	290	22	27	131	141	6	M20
SNG 520-617	90	37/16 3½	180	380	110	40	70	112	160	215	320	26	32	137,5	147,5	6	M24
SNG 522-619	100	315/16 4	200	410	120	45	80	125	175	239	350	26	32	147,5	157,5	6	M24
SNG 524-620	110	43/16 4¼	215	410	120	45	86	140	185	271	350	26	32	157,5	167,5	6	M24
SNG 526	115	47/16 4½	230	445	130	50	90	150	190	290	380	28	35	167,5	177,5	6	M24
SNG 528	125	415/16 5	250	500	150	50	98	150	205	302	420	35	42	177,5	187,5	6	M30
SNG 530	135	53/16 5¼	270	530	160	60	106	160	220	323	450	35	42	192,5	202,5	6	M30
SNG 532	140	57/16 5½	290	550	160	60	114	170	235	344	470	35	42	202,5	212,5	6	M30

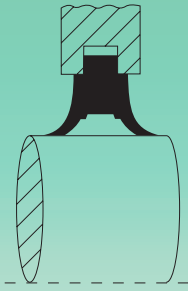

Obturator de poliuretano "TSNG" para: SNG-SNU
"TSNG" polyurethan seal for: SNG-SNU

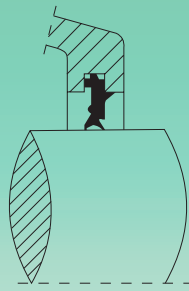

Obturator de caucho "TSNU" para: SNG-SNU
"TSNU" rubber seal for: SNG-SNU

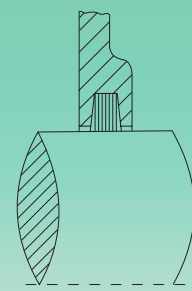

Obturator de fieltro "TSNC" para: SNG-SNU
"TSNC" felt seal for: SNG-SNU

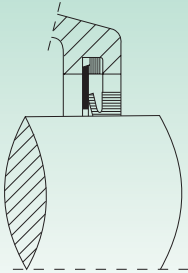

Obturator de anillo en v "TSNA" para: SNG-SNU
"TSNA" v-ring seal for: SNG-SNU

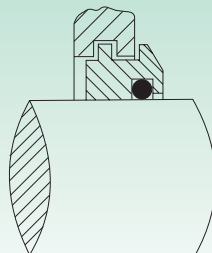

Obturator de laberinto "TSNS" para: SNG-SNU
"TSNS" labyrinth seal for: SNG-SNU

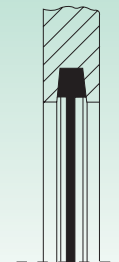

Tapa de cierre "A" para: SNG-SNU-SN
"A" end cover for: SNG-SNU-SN

Rodamiento autoalineable de bolas (agujero cónico) Self-aligning ball bearing (conical bore)	Rodamiento autoalineable de rodillos (agujero cónico) Self-aligning roller bearing (conical bore)	Manguito (métrica) Adapter sleeve (metric)	Aro de centrado Locating ring		Peso Weight kg	"TSNG" Obturator de poliuretano Polyurethan seal	"TSNU" Obturator de caucho Rubber seal	"TSNC" Obturator de fieltro Felt seal	"TSNA" Obturator de anillo en V V seal	"TSNS" Obturator de laberinto Labyrinth seal	"A" Tapa de cierre End cover	Tipo Type
			Tipo Type	Cant. Q.ty								
1205 K	-	H 205	SR 52x5	2	2,1	TSNG 505	TSNU 505	TSNC 505	TSNA 505	TSNS 505	A 505	SNG 505
1206 K	-	H 205	SR 62x5	2	2,4	TSNG 506	TSNU 506	TSNC 506	TSNA 506	TSNS 506	A 506-605	SNG 506-605
1207 K	-	H 207	SR 72x8,5	2	2,2	TSNG 507	TSNU 507	TSNC 507	TSNA 507	TSNS 507	A 507-606	SNG 507-606
2207 K	22207 K	H 307	SR 72x5,5	2								
1208 K	-	H 208	SR 80x10,5	2	2,8	TSNG 508	TSNU 508	TSNC 508	TSNA 508	TSNS 508	A 508-607	SNG 508-607
2208 K	22208 K	H 308	SR 80x8	2								
1209 K	-	H 209	SR 85x5,5	2	3,0	TSNG 509	TSNU 509	TSNC 509	TSNA 509	TSNS 509	A 509	SNG 509
2209 K	22209 K	H 309	SR 85x7	1								
1210 K	-	H 210	SR 90x10,5	2	3,1	TSNG 510	TSNU 510	TSNC 510	TSNA 510	TSNS 510	A 510-608	SNG 510-608
2210 K	22210 K	H 310	SR 90x9	2								
1211 K	-	H 211	SR 100x11,5	2	4,5	TSNG 511	TSNU 511	TSNC 511	TSNA 511	TSNS 511	A 511-609	SNG 511-609
2211 K	22211 K	H 311	SR 100x9,5	2								
1212 K	-	H 212	SR 110x13	2	5,0	TSNG 512	TSNU 512	TSNC 512	TSNA 512	TSNS 512	A 512-610	SNG 512-610
2212 K	22212 K	H 312	SR 110x10	2								
1213 K	-	H 213	SR 120x14	2	6,1	TSNG 513	TSNU 513	TSNC 513	TSNA 513	TSNS 513	A 513-611	SNG 513-611
2213 K	22213 K	H 313	SR 120x10	2								
1215 K	-	H 215	SR 130x15,5	2	6,5	TSNG 515	TSNU 515	TSNC 515	TSNA 515	TSNS 515	A 515-612	SNG 515-612
2215 K	22215 K	H 315	SR 130x12,5	2								
1216 K	-	H 216	SR 140x16	2	9,0	TSNG 516	TSNU 516	TSNC 516	TSNA 516	TSNS 516	A 516-613	SNG 516-613
2216 K	22216 K	H 316	SR 140x12,5	2								
1217 K	-	H 217	SR 150x16,5	2	10,2	TSNG 517	TSNU 517	TSNC 517	TSNA 517	TSNS 517	A 517	SNG 517
2217 K	22217 K	H 317	SR 150x12,5	2								
1218 K	-	H 218	SR 160x17,5	2	12,4	TSNG 518	TSNU 518	TSNC 518	TSNA 518	TSNS 518	A 518-615	SNG 518-615
2218 K	22218 K	H 318	SR 160x12,5	2								
2218 K	23218 K	H 2318	SR 160x12,5	1								
1219 K	-	H 219	SR 170x18	2	13,5	TSNG 519	TSNU 519	TSNC 519	TSNA 519	TSNS 519	A 519-616	SNG 519-616
2219 K	22219 K	H 319	SR 170x12,5	2								
2220 K	22220 K	H 320	SR 180x12	2	17,5	TSNG 520	TSNU 520	TSNC 520	TSNA 520	TSNS 520	A 520-617	SNG 520-617
-	23220 K	H 2320	SR 180x9,7	1								
2222 K	22222 K	H 322	SR 200x13,5	2	20,5	TSNG 522	TSNU 522	TSNC 522	TSNA 522	TSNS 522	A 522-619	SNG 522-619
-	23222 K	H 2322	SR 200x10	1								
-	22224 K	H 3124	SR 215x14	2	25,5	TSNG 524	TSNU 524	TSNC 524	TSNA 524	TSNS 524	A 524-620	SNG 524-620
-	23224 K	H 2324	SR 215x10	1								
-	22226 K	H 3126	SR 230x13	2	33,0	TSNG 526	TSNU 526	TSNC 526	TSNA 526	TSNS 526	A 526	SNG 526
-	23226 K	H 2326	SR 230x10	1								
-	22228 K	H 3128	SR 250x15	2	42,0	TSNG 528	TSNU 528	TSNC 528	TSNA 528	TSNS 528	A 528	SNG 528
-	23228 K	H 2328	SR 250x10	1								
-	22230 K	H 3130	SR 270x16,5	2	53,0	TSNG 530	TSNU 530	TSNC 530	TSNA 530	TSNS 530	A 530	SNG 530
-	23230 K	H 2330	SR 270x10	1								
-	22232 K	H 3132	SR 290x17	2	55,0	TSNG 532	TSNU 532	TSNC 532	TSNA 532	TSNS 532	A 532	SNG 532
-	23232 K	H 2332	SR 290x10	1								

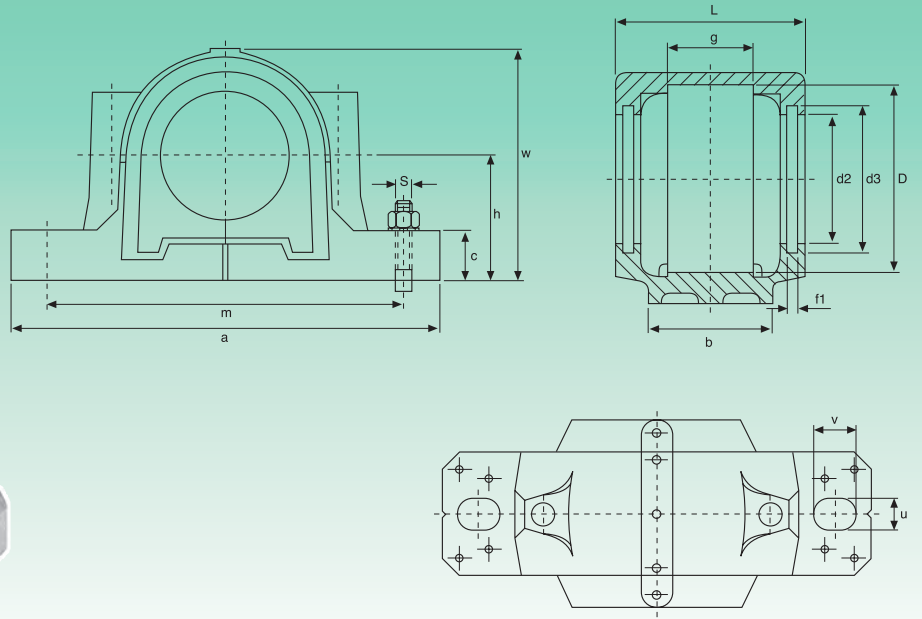
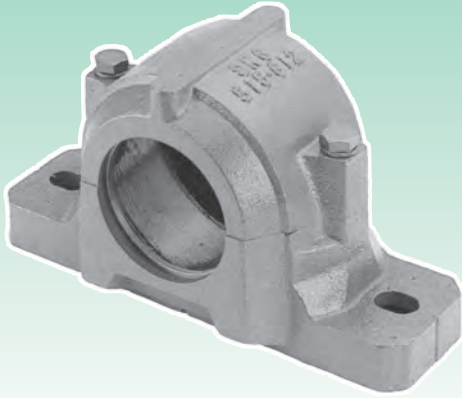

Tipo Type	Diámetro eje Shaft diameter			Dimensiones - Dimensions													Bul. fj. Bolt Size	
				D H8	a	b	c	g H12	h js11	L	w	m	U	V	d2 H12	d3 H12	f1	S
	mm	inch		mm/inch														
SNG 508-607	30	1 1/8	13/16	80	205	60	25	39	60	85	106	170	15	20	51,5	59,5	5	M12
SNG 510-608	35	1 5/16	13/8	90	205	60	25	41	60	90	112	170	15	20	62	70,5	5	M12
SNG 511-609	40	1 1/2	19/16	100	255	70	28	44	70	95	127	210	18	23	67	75,5	5	M16
SNG 512-610	45	1 11/16	1 3/4	110	255	70	30	48	70	105	133	210	18	23	72	80,5	5	M16
SNG 513-611	50	1 15/16	2	120	275	80	30	51	80	110	148	230	18	24	77	85,5	5	M16
SNG 515-612	55	2 1/8	23/16	130	280	80	30	56	80	115	154	230	18	26	87	95,5	5	M16
SNG 516-613	60	2 1/4	25/16	140	315	90	32	58	95	120	175	260	22	29	92,5	101	5	M20
SNG 518-615	65	2 7/16	2 1/2	160	345	100	35	65	100	140	192	290	22	27	102,5	111	5	M20
SNG 519-616	70	2 11/16	2 3/4	170	345	100	35	68	112	145	209	290	22	27	131	141	6	M20
SNG 520-617	75	2 15/16	3	180	380	110	40	70	112	160	215	320	26	32	137,5	147,5	6	M24
SNG 522-619	85	3 5/16	3 3/8	200	410	120	45	80	125	175	239	350	26	32	147,5	157,5	6	M24
SNG 524-620	90	3 7/16	3 1/2	215	410	120	45	86	140	185	271	350	26	32	157,5	167,5	6	M24

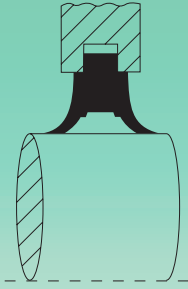

Obtención de poliuretano "TSNG" para: SNG-SNU
"TSNG" polyurethan seal for: SNG-SNU

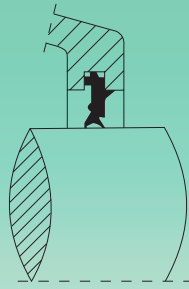

Obtención de caucho "TSNU" para: SNG-SNU
"TSNU" rubber seal for: SNG-SNU

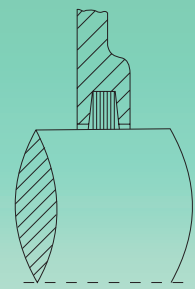

Obtención de fieltro "TSNC" para: SNG-SNU
"TSNC" felt seal for: SNG-SNU

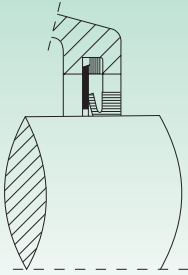

Obtención de anillo en v "TSNA" para: SNG-SNU
"TSNA" v-ring seal for: SNG-SNU

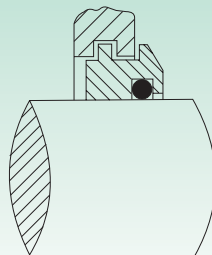

Obtención de laberinto "TSNS" para: SNG-SNU
"TSNS" labyrinth seal for: SNG-SNU

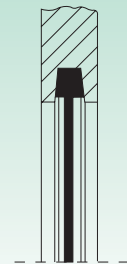

Tapa de cierre "A" para: SNG-SNU-SN
"A" end cover for: SNG-SNU-SN

Rodamiento autoalineable de bolas (agujero cónico) Self-aligning ball bearing (conical bore)	Rodamiento autoalineable de rodillos (agujero cónico) Self-aligning roller bearing (conical bore)	Manguito (métrica) Adapter sleeve (metric)	Aro de centrado Locating ring		Peso Weight kg	"TSNG" Obtención de poliuretano Polyurethan seal	"TSNU" Obtención de caucho Rubber seal	"TSNC" Obtención de fieltro Felt seal	"TSNA" Obtención de anillo en V de anillo en V seal	"TSNS" Obtención de laberinto Labyrinth seal	"A" Tapa de cierre End cover	Tipo Type
			Tipo Type	Cant. Q.ty								
1307 K	-	H 307	SR 80x9	2	2,8	TSNG 607	TSNU 607	TSNC 607	TSNA 607	TSNS 607	A 508-607	SNG 508-607
2307 K	-	H 2307	SR 80x8	1								
1308 K	21308 K	H 308	SR 90x9	2	3,1	TSNG 608	TSNU 608	TSNC 608	TSNA 608	TSNS 608	A 510-608	SNG 510-608
2308 K	22308 K	H 2308	SR 90x8	1								
1309 K	21309 K	H 309	SR 100x9,5	2	4,5	TSNG 609	TSNU 609	TSNC 609	TSNA 609	TSNS 609	A 511-609	SNG 511-609
2309 K	22309 K	H 2309	SR 100x8	1								
1310 K	21310 K	H 310	SR 110x10,5	2	5,0	TSNG 610	TSNU 610	TSNC 610	TSNA 610	TSNS 610	A 512-610	SNG 512-610
2310 K	22310 K	H 2310	SR 110x8	1								
1311 K	21311 K	H 311	SR 120x11	2	6,1	TSNG 611	TSNU 611	TSNC 611	TSNA 611	TSNS 611	A 513-611	SNG 513-611
2311 K	22311 K	H 2311	SR 120x8	1								
1312 K	21312 K	H 312	SR 130x12,5	2	6,5	TSNG 612	TSNU 612	TSNC 612	TSNA 612	TSNS 612	A 515-612	SNG 515-612
2312 K	22312 K	H 2312	SR 130x10	1								
1313 K	21313 K	H 313	SR 140x12,5	2	9,0	TSNG 613	TSNU 613	TSNC 613	TSNA 613	TSNS 613	A 516-613	SNG 516-613
2313 K	22313 K	H 2313	SR 140x10	1								
1315 K	21315 K	H 315	SR 160x14	2	12,4	TSNG 615	TSNU 615	TSNC 615	TSNA 615	TSNS 615	A 518-615	SNG 518-615
2315 K	22315 K	H 2315	SR 160x10	1								
1316 K	21316 K	H 316	SR 170x14,5	2	13,5	TSNG 616	TSNU 616	TSNC 616	TSNA 616	TSNS 616	A 519-616	SNG 519-616
2316 K	22316 K	H 2316	SR 170x10	1								
1317 K	21317 K	H 317	SR 180x14,5	2	17,5	TSNG 617	TSNU 617	TSNC 617	TSNA 617	TSNS 617	A 520-617	SNG 520-617
2317 K	22317 K	H 2317	SR 180x10	1								
1319 K	-	H 319	SR 200x17,5	2	20,5	TSNG 619	TSNU 619	TSNC 619	TSNA 619	TSNS 619	A 522-619	SNG 522-619
2319 K	22319 K	H 2319	SR 200x13	1								
-	-	H -	-	-	25,5	TSNG 620	TSNU 620	TSNC 620	TSNA 620	TSNS 620	A 524-620	SNG 524-620
2320 K	22320 K	H 2320	SR 215x13	1								

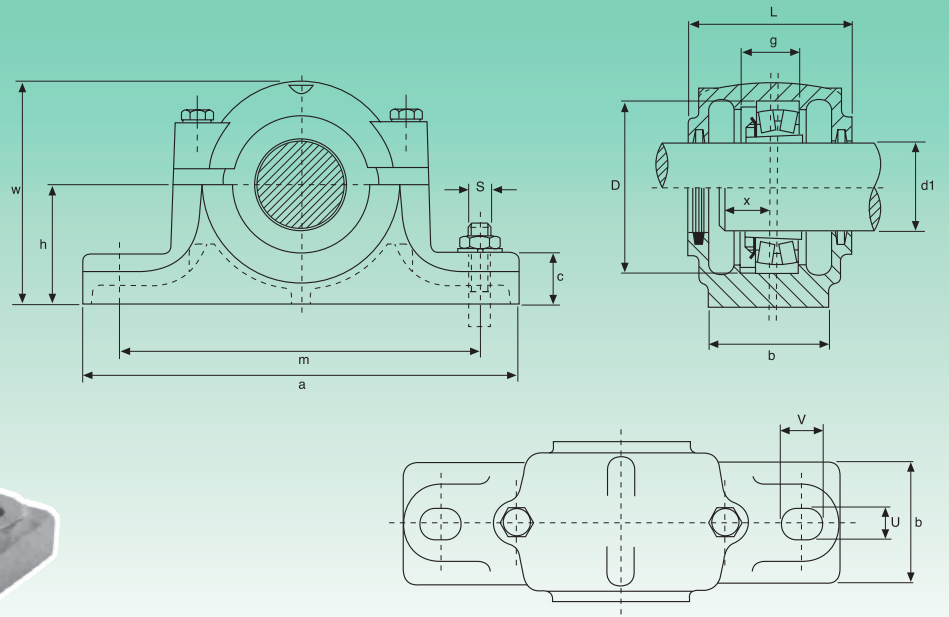
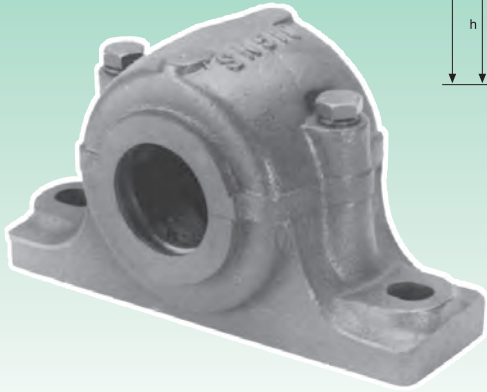

Tipo Type	Diámetro eje Shaft diameter		Dimensiones - Dimensions										Bul. fj. Bolt Size	
	d1		D H8	a	b	c	g H12	h h12	L ± 5	w	m	U	V	S
	mm	inch	mm/inch											
SN 506	25	1	62	185	52	22	30	50	77	90	150	15	20	M12
SN 507	30	1 1/8	72	185	52	22	33	50	82	95	150	15	20	M12
SN 508	35	1 1/4	80	205	60	25	33	60	85	110	170	15	20	M12
SN 509	40	1 1/2	85	205	60	25	31	60	85	112	170	15	20	M12
SN 510	45	1 3/4	90	205	60	25	33	60	90	115	170	15	20	M12
SN 511	50	2	100	255	70	28	33	70	95	130	210	18	23	M16
SN 512	55	2 1/8	110	255	70	30	38	70	105	135	210	18	23	M16
SN 513	60	2 1/4	120	275	80	30	43	80	110	150	230	18	23	M16
SN 515	65	2 1/2	130	280	80	30	41	80	115	155	230	18	23	M16
SN 516	70	2 3/4	140	315	90	32	43	95	120	175	260	22	27	M20
SN 517	75	3	150	320	90	32	46	95	125	185	260	22	27	M20
SN 518	80	3 1/4	160	345	100	35	62,4	100	145	195	290	22	27	M20
SN 519	85	-	170	345	100	35	53	112	140	210	290	22	27	M20
SN 520	90	3 1/2	180	380	110	40	70,3	112	160	218	320	26	32	M24
SN 522	100	4	200	410	120	45	80	125	175	240	350	26	32	M24
SN 524	110	4 1/4	215	410	120	45	86	140	185	270	350	26	32	M24
SN 526	115	4 1/2	230	445	130	50	90	150	190	290	380	28	36	M24
SN 528	125	5	250	500	150	50	98	150	205	305	420	33	42	M30
SN 530	135	5 1/4	270	530	160	60	106	160	220	325	450	33	42	M30
SN 532	140	5 1/2	290	550	160	60	114	170	235	345	470	33	42	M30

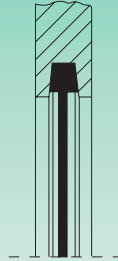
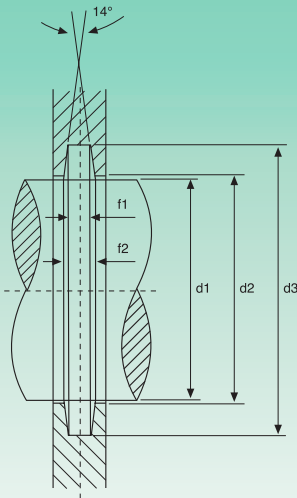

Tapa de cierre "A" para: SNG-SNU-SN
"A" end cover for: SNG-SNU-SN

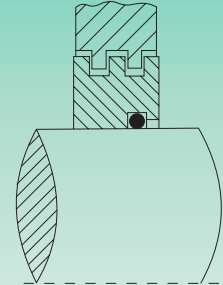

Obturación de laberinto "TS" para: SN-SD
"TS" labyrinth seal for: SN-SD

Si no se especifica otra tipología se suministra el soporte abierto de tipo "B"
Unless specified "B" type open housing supplied

Dimensiones - Dimensions					Peso Weight	Rodamiento autoalineable de bolas (agujero cónico) Self-aligning ball bearing (conical bore)	Rodamiento autoalineable de rodillos (agujero cónico) Self-aligning roller bearing (conical bore)	Manguito Adapter sleeve		Aro de centrado Locating ring		"A" Tapa de cierre End cover	"TS" Obturación de laberinto Labyrinth seal	Tipo Type
X	d2 H12	d3 H13	f1 H13	f2				mm	inch	Tipo Type	Cant. Q.ty			
22	26,5	38	4	5,4	1,6	1206 K	-	H 206	HE 206	SR 62x7	2	A 506	TS 506	SN 506
						2206 K	22206 K	H 306	HE 306	SR 62x10	1			
24	31,5	43	4	5,4	2,1	1207 K	-	H 207	HE 207	SR 72x8	2	A 507	TS 507	SN 507
						2207 K	22207 K	H 307	HE 307	SR 72x10	1			
26	36,5	48	4	5,4	2,7	1208 K	-	H 208	HE 208	SR 80x7,5	2	A 508	TS 508	SN 508
						2208 K	22208 K	H 308	HE 308	SR 80x10	1			
28	41,5	53	4	5,4	2,8	1209 K	-	H 209	HE 209	SR 85x6	2	A 509	TS 509	SN 509
						2209 K	22209 K	H 309	HE 309	SR 85x8	1			
28	46,5	58	4	5,4	3,0	1210 K	-	H 210	HE 210	SR 90x6,5	2	A 510	TS 510	SN 510
						2210 K	22210 K	H 310	HE 310	SR 90x10	1			
30	51,5	67	5	6,9	4,0	1211 K	-	H 211	HE 211	SR 100x6	2	A 511	TS 511	SN 511
						2211 K	22211 K	H 311	HE 311	SR 100x8	1			
32	56,5	72	5	6,9	4,5	1212 K	-	H 212	HE 212	SR 110x8	2	A 512	TS 512	SN 512
						2212 K	22212 K	H 312	HE 312	SR 110x10	1			
36	62	77	5	6,8	5,5	1213 K	-	H 213	HE 213	SR 120x10	2	A 513	TS 513	SN 513
						2213 K	22213 K	H 313	HE 313	SR 120x12	1			
38	67	82	5	6,8	6,0	1215 K	-	H 215	HE 215	SR 130x8	2	A 515	TS 515	SN 515
						2215 K	22215 K	H 315	HE 315	SR 130x10	1			
40	72	89	6	8,1	8,2	1216 K	-	H 216	HE 216	SR 140x8,5	2	A 516	TS 516	SN 516
						2216 K	22216 K	H 316	HE 316	SR 140x10	1			
42	77	94	6	8,1	9,0	1217 K	-	H 217	HE 217	SR 150x9	2	A 517	TS 517	SN 517
						2217 K	22217 K	H 317	HE 317	SR 150x10	1			
50	82	99	6	8,1	11,6	1218 K	22218 K	H 218	HE 218	SR 160x16,2	2	A 518	TS 518	SN 518
						2218 K	23218 K	H 318	HE 318	SR 160x11,2	2			
						1219 K	-	H 219	HE 219	SR 160x10	1			
52	87	104	6	8,1	11,8	2219 K	22219 K	H 319	HE 319	SR 170x10,5	2	A 519	TS 519	SN 519
						2219 K	22219 K	H 319	HE 319	SR 170x10	1			
54	92	111	7	9,3	15,5	2220 K	22220 K	H 320	HE 320	SR 180x12,1	2	A 520	TS 520	SN 520
						-	23220 K	H 2320	HE 2320	SR 180x10	1			
60	102	125	8	10,8	19	2222 K	22222 K	H 322	HE 322	SR 200x13,5	2	A 522	TS 522	SN 522
						-	23222 K	H 2322	HE 2322	SR 200x10	1			
64	113	135	8	10,7	23	-	22224 K	H 3124	HE 3124	SR 215x14	2	A 524	TS 524	SN 524
						-	23224 K	H 2324	HE 2324	SR 215x10	1			
64	118	140	8	10,7	28	-	22226 K	H 3126	HE 3126	SR 230x13	2	A 526	TS 526	SN 526
						-	23226 K	H 2326	HE 2326	SR 230x10	1			
70	128	154	9	12,2	37	-	22228 K	H 3128	HE 3128	SR 250x15	2	A 528	TS 528	SN 528
						-	23228 K	H 2328	HE 2328	SR 250x10	1			
76	138	164	9	12,2	44	-	22230 K	H 3130	HE 3130	SR 270x16,5	2	A 530	TS 530	SN 530
						-	23230 K	H 2330	HE 2330	SR 270x10	1			
80	143	173	10	13,7	50	-	22232 K	H 3132	HE 3132	SR 290x17	2	A 532	TS 532	SN 532
						-	23232 K	H 2332	HE 2332	SR 290x10	1			

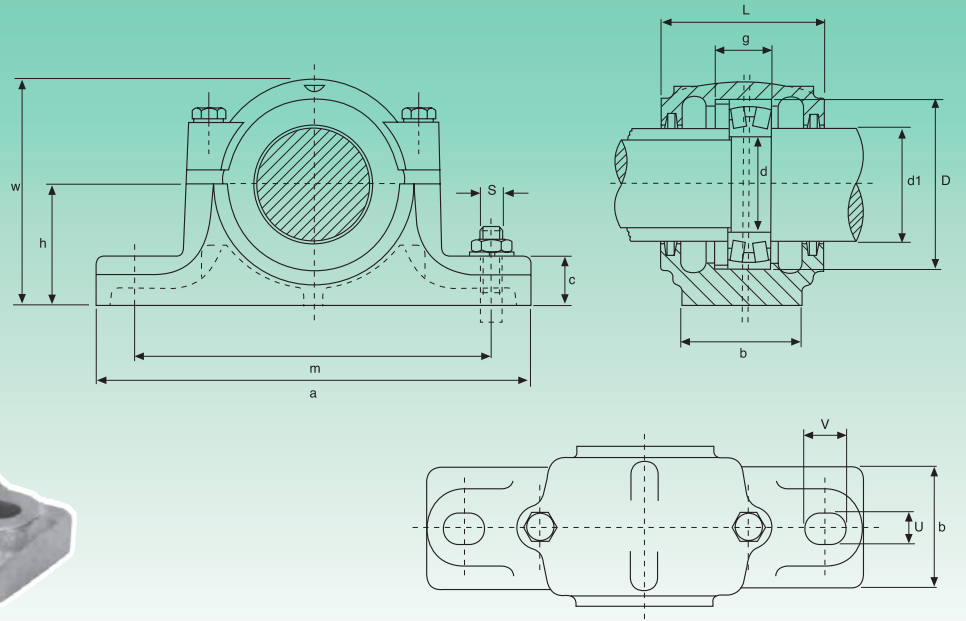
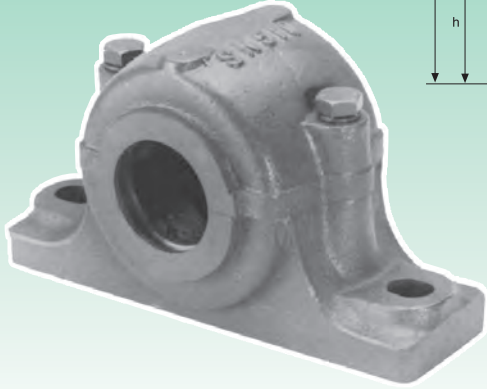

Tipo Type	Diámetro eje Shaft diameter			Dimensiones - Dimensions											
	d	d0	d1	D H8	a	b	c	g H12	h h12	L ± 5	w	m	n	U	V
	mm			mm											
SN 207	35	30	45	72	185	52	22	33	50	82	95	150	-	15	20
SN 208	40	35	50	80	205	60	25	33	60	85	110	170	-	15	20
SN 209	45	40	55	85	205	60	25	31	60	85	112	170	30	15	20
SN 210	50	45	60	90	205	60	25	33	60	90	115	170	30	15	20
SN 211	55	50	65	100	255	70	28	33	70	95	130	210	35	18	23
SN 212	60	55	70	110	255	70	30	38	70	105	135	210	35	18	23
SN 213	65	60	75	120	275	80	30	43	80	110	150	230	40	18	23
SN 215	75	65	85	130	280	80	30	41	80	115	155	230	40	18	23
SN 216	80	70	90	140	315	90	32	43	95	120	175	260	50	22	27
SN 217	85	75	95	150	320	90	32	46	95	125	185	260	50	22	27
SN 218	90	80	100	160	345	100	35	62,4	100	145	195	290	50	22	27
SN 220	100	90	115	180	380	110	40	70,3	112	160	218	320	60	26	32
SN 222	110	100	125	200	410	120	45	80	125	175	240	350	70	26	32
SN 224	120	110	135	215	410	120	45	86	140	185	270	350	70	26	32
SN 226	130	115	145	230	445	130	50	90	150	190	290	380	70	28	36
SN 228	140	125	155	250	500	150	50	98	150	205	305	420	80	33	42
SN 230	150	135	165	270	530	160	60	106	160	220	325	450	90	33	42
SN 232	160	140	175	290	550	160	60	114	170	235	345	470	90	33	42

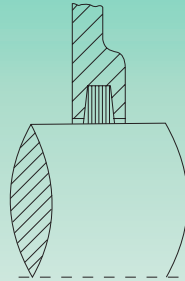
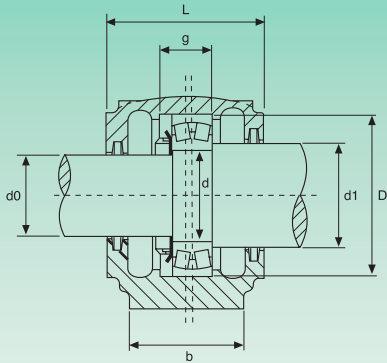

Obturation de fieltro "TSNC" para: SNG-SNU
"TSNC" felt seal for: SNG-SNU

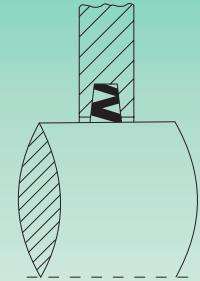

Obturation de NBR "ZF" para: SN
"ZF" NBR seal for: SN

S		Rodamiento autoalineable de bolas (agujero cónico) Self-aligning ball bearing (conical bore)	Rodamiento autoalineable de rodillos (agujero cónico) Self-aligning roller bearing (conical bore)	Tuerca de bloqueo Lock nut	Arandela Washer	"TSNC" Obturation de fieltro Felt seal		"ZF" Obturation de NBR NBR seal		Aro de centrado Locating ring		Tipo Type
2 Bul. Fij. 2 Bolt size	4 Bul. Fij. 4 Bolt size			KM	MB	d0	d1	d0	d1	Tipo Type	Cant. Q.ty	
M 12	-	1207 2207	22207	KM 07	MB 07	TSNC 207	TSNC 210	ZF 207	ZF 210	SR 72x8 SR 72x10	2 1	SN 207
M 12	-	1208 2208	22208	KM 08	MB 08	TSNC 208	TSNC 211	ZF 208	ZF 211	SR 80x7,5 SR 80x10	2 1	SN 208
M 12	M 10	1209 2209	22209	KM 09	MB 09	TSNC 209	TSNC 212	ZF 209	ZF 212	SR 85x6 SR 85x8	2 1	SN 209
M 12	M 10	1210 2210	22210	KM 10	MB 10	TSNC 210	TSNC 213	ZF 210	ZF 213	SR 90x6,5 SR 90x10	2 1	SN 210
M 16	M 12	1211 2211	22211	KM 11	MB 11	TSNC 211	TSNC 215	ZF 211	ZF 215	SR 100x6 SR 100x8	2 1	SN 211
M 16	M 12	1212 2212	22212	KM 12	MB 12	TSNC 212	TSNC 216	ZF 212	ZF 216	SR 110x8 SR 110x10	2 1	SN 212
M 16	M 12	1213 2213	22213	KM 13	MB 13	TSNC 213	TSNC 217	ZF 213	ZF 217	SR 120x10 SR 120x12	2 1	SN 213
M 16	M 12	1215 2215	22215	KM 15	MB 15	TSNC 215	TSNC 219	ZF 215	ZF 219	SR 130x8 SR 130x10	2 1	SN 215
M 20	M 16	1216 2216	22216	KM 16	MB 16	TSNC 216	TSNC 220	ZF 216	ZF 220	SR 140x8,5 SR 140x10	2 1	SN 216
M 20	M 16	1217 2217	22217	KM 17	MB 17	TSNC 217	TSNC 221	ZF 217	ZF 221	SR 150x9 SR 150x10	2 1	SN 217
M 20	M 16	1218 2218	22218 23218	KM 18	MB 18	TSNC 218	TSNC 222	ZF 218	ZF 222	SR 160x16,2 SR 160x11,2 SR 160x10	2 2 1	SN 218
M 24	M 16	2220	22220 23220	KM 20	MB 20	TSNC 220	TSNC 226	ZF 220	ZF 226	SR 180x12,1 SR 180x10	2 1	SN 220
M 24	M 16	2222	22222 23222	KM 22	MB 22	TSNC 222	TSNC 228	ZF 222	ZF 228	SR 200x13,5 SR 200x10	2 1	SN 222
M 24	M 16	-	22224 23224	KM 24	MB 24	TSNC 224	TSNC 230	ZF 224	ZF 230	SR 215x14 SR 215x10	2 1	SN 224
M 24	M 20	-	22226 23226	KM 26	MB 26	TSNC 226	TSNC 233	ZF 226	ZF 233	SR 230x13 SR 230x10	2 1	SN 226
M 30	M 24	-	22228 23228	KM 28	MB 28	TSNC 228	TSNC 235	ZF 228	ZF 235	SR 250x15 SR 250x10	2 1	SN 228
M 30	M 24	-	22230 23230	KM 30	MB 30	TSNC 230	TSNC 237	ZF 230	ZF 237	SR 270x16,5 SR 270x10	2 1	SN 230
M 30	M 24	-	22232 23232	KM 32	MB 32	TSNC 232	TSNC 239	ZF 232	ZF 239	SR 290x17 SR 290x10	2 1	SN 232

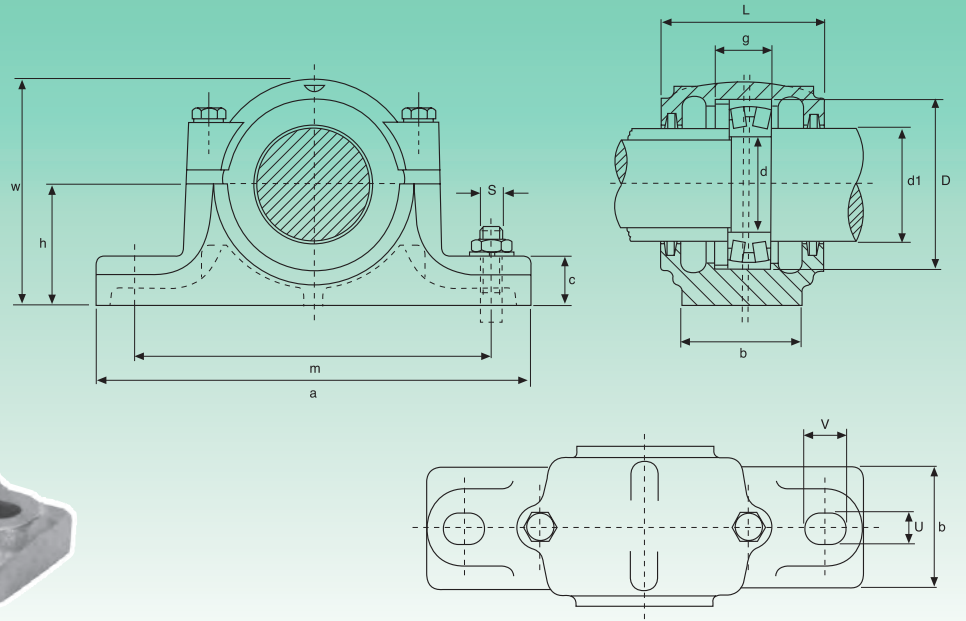
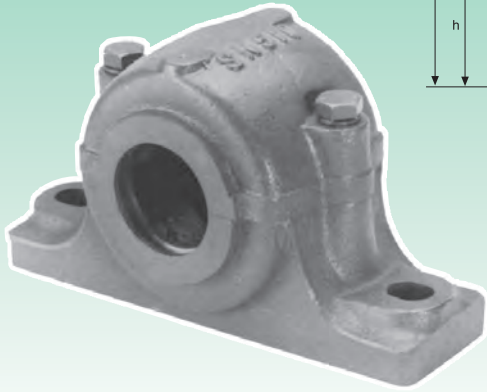

Tipo Type	Diámetro eje Shaft diameter			Dimensiones - Dimensions											
	d	d0	d1	D H8	a	b	c	g H12	h h12	L ± 5	w	m	n	U	V
	mm			mm											
SN 307	35	30	45	80	205	60	25	41	60	90	110	170	-	15	20
SN 308	40	35	50	90	205	60	25	43	60	95	115	170	-	15	20
SN 309	45	40	55	100	255	70	28	46	70	105	130	210	-	18	23
SN 310	50	45	60	110	255	70	30	50	70	115	135	210	-	18	23
SN 311	55	50	65	120	275	80	30	53	80	120	150	230	40	18	23
SN 312	60	55	70	130	280	80	30	56	80	125	155	230	40	18	23
SN 313	65	60	75	140	315	90	32	58	95	130	175	260	50	22	27
SN 315	75	65	85	160	345	100	35	65	100	140	195	290	50	22	27
SN 316	80	70	90	170	345	100	35	68	112	145	212	290	50	22	27
SN 317	85	75	95	180	380	110	40	70	112	155	218	320	60	26	32
SN 318	90	80	100	190	400	110	33	74	112	160	230	320	60	26	35
SN 319	95	85	110	200	420	120	36	77	125	170	245	350	70	26	35
SN 320	100	90	115	215	420	120	38	83	140	175	280	350	70	26	35
SN 322	110	100	125	240	460	130	40	90	150	190	300	390	70	28	38
SN 324	120	110	135	260	540	160	50	96	160	205	325	450	90	33	42
SN 326	130	115	150	280	560	160	50	103	170	215	350	470	90	33	42
SN 328	140	125	160	300	630	170	55	112	180	235	375	520	90	35	45
SN 330	150	135	170	320	680	180	55	118	190	245	395	560	90	35	45
SN 332	160	140	180	340	710	190	60	124	200	255	415	580	100	42	52

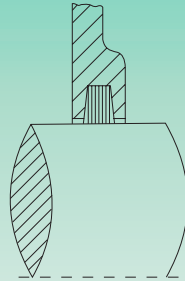
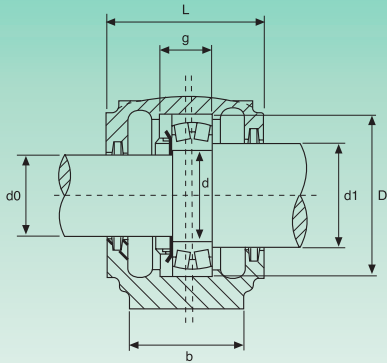

Obtención de fieltro "TSNC" para: SNG-SNU
"TSNC" felt seal for: SNG-SNU

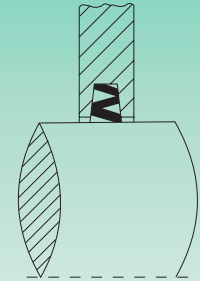

Obtención de NBR "ZF" para: SN
"ZF" NBR seal for: SN

S		Rodamiento autoalineable de bolas (agujero cónico) Self-aligning ball bearing (conical bore)	Rodamiento autoalineable de rodillos (agujero cónico) Self-aligning roller bearing (conical bore)	Tuerca de bloqueo Lock nut	Arandela Washer	"TSNC" Obtención de fieltro Felt seal		"ZF" Obtención de NBR NBR seal		Aro de centrado Locating ring		Tipo Type
2 Bul. Fij. 2 Bolt size	4 Bul. Fij. 4 Bolt size			KM	MB	d0	d1	d0	d1	Tipo Type	Cant. Q.ty	
M 12	-	1307 2307	-	KM 07	MB 07	TSNC 307	TSNC 310	ZF 307	ZF 310	SR 80x10 SR 80x10	2 1	SN 307
M 12	-	1308 2308	21308 22308	KM 08	MB 08	TSNC 308	TSNC 311	ZF 308	ZF 311	SR 90x10 SR 90x10	2 1	SN 308
M 16	-	1309 2309	21309 22309	KM 09	MB 09	TSNC 309	TSNC 312	ZF 309	ZF 312	SR 100x10,5 SR 100x10	2 1	SN 309
M 16	-	1310 2310	21310 22310	KM 10	MB 10	TSNC 310	TSNC 313	ZF 310	ZF 313	SR 110x11,5 SR 110x10	2 1	SN 310
M 16	M 12	1311 2311	21311 22311	KM 11	MB 11	TSNC 311	TSNC 315	ZF 311	ZF 315	SR 120x12 SR 120x10	2 1	SN 311
M 16	M 12	1312 2312	21312 22312	KM 12	MB 12	TSNC 312	TSNC 316	ZF 312	ZF 316	SR 130x12,5 SR 130x10	2 1	SN 312
M 20	M 16	1313 2313	21313 22313	KM 13	MB 13	TSNC 313	TSNC 317	ZF 313	ZF 317	SR 140x12,5 SR 140x10	2 1	SN 313
M 20	M 16	1315 2315	21315 22315	KM 15	MB 15	TSNC 315	TSNC 319	ZF 315	ZF 319	SR 160x14 SR 160x10	2 1	SN 315
M 20	M 16	1316 2316	21316 22316	KM 16	MB 16	TSNC 316	TSNC 320	ZF 316	ZF 320	SR 170x14,5 SR 170x10	2 1	SN 316
M 24	M 16	1317 2317	21317 22317	KM 17	MB 17	TSNC 317	TSNC 321	ZF 317	ZF 321	SR 180x14,5 SR 180x10	2 1	SN 317
M 24	M 16	1318 2318	21318 22318	KM 18	MB 18	TSNC 318	TSNC 322	ZF 318	ZF 322	SR 190x15,5 SR 190x10	2 1	SN 318
M 24	M 16	1319 2319	21319 22319	KM 19	MB 19	TSNC 319	TSNC 324	ZF 319	ZF 324	SR 200x16 SR 200x10	2 1	SN 319
M 24	M 16	1320 2320	21320 22320	KM 20	MB 20	TSNC 320	TSNC 326	ZF 320	ZF 326	SR 215x18 SR 215x10	2 1	SN 320
M 24	M 16	1322 2322	22322	KM 22	MB 22	TSNC 322	TSNC 328	ZF 322	ZF 328	SR 240x20 SR 240x10	2 1	SN 322
M 30	M 20	-	22324	KM 24	MB 24	TSNC 324	TSNC 330	ZF 324	ZF 330	SR 260x10	1	SN 324
M 30	M 20	-	22326	KM 26	MB 26	TSNC 326	TSNC 334	ZF 326	ZF 334	SR 280x10	1	SN 326
M 30	M 20	-	22328	KM 28	MB 28	TSNC 328	TSNC 336	ZF 328	ZF 336	SR 300x10	1	SN 328
M 30	M 20	-	22330	KM 30	MB 30	TSNC 330	TSNC 338	ZF 330	ZF 338	SR 320x10	1	SN 330
M 36	M 24	-	22332	KM 32	MB 32	TSNC 332	TSNC 340	ZF 332	ZF 340	SR 340x10	1	SN 332

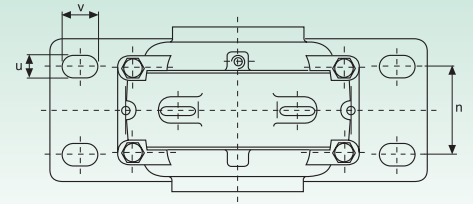
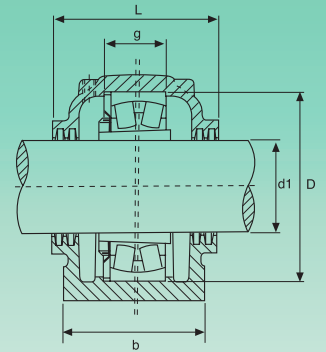
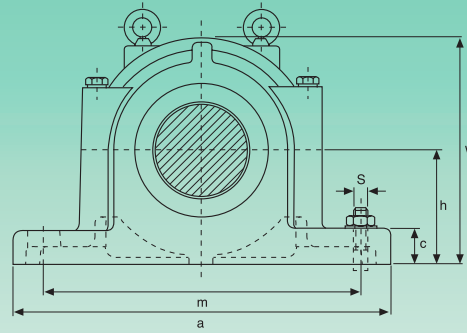
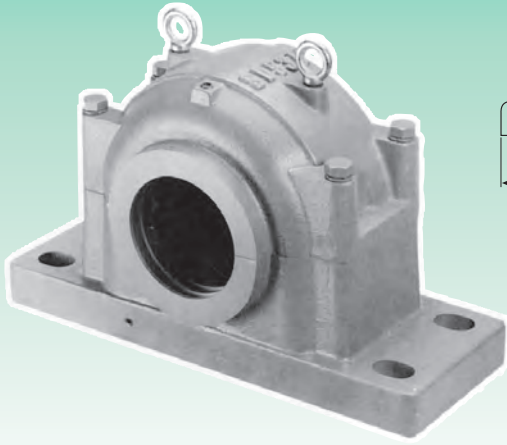

Tipo Type	Diámetro eje Shaft diameter	Dimensiones - Dimensions											
	d1	D H8	a	b	c	g H12	h h12	L ± 5	w	m	n	U	V
	mm	mm											
SD 3034	150	260	540	200	50	77	160	230	320	450	110	36	52
SD 3036	160	280	560	220	50	84	170	250	340	470	120	36	52
SD 3038	170	290	560	220	50	85	170	250	345	470	120	36	52
SD 3040	180	310	620	230	60	92	180	270	360	510	140	36	52
SD 3044	200	340	700	260	65	100	200	290	400	570	160	36	55
SD 3048	220	360	740	270	65	102	210	300	420	610	170	36	55
SD 3052	240	400	820	300	70	114	240	330	475	680	190	43	62
SD 3056	260	420	860	320	85	116	250	350	500	710	200	43	62
SD 3060	280	460	920	330	85	128	280	360	550	770	210	43	62
SD 3064	300	480	940	340	85	131	280	370	560	790	210	43	62
SD 3068	320	520	1020	370	100	143	310	400	615	860	230	50	70
SD 3072	340	540	1060	390	100	144	325	410	640	890	250	50	70
SD 3076	360	560	1080	390	100	145	340	410	665	900	260	50	70

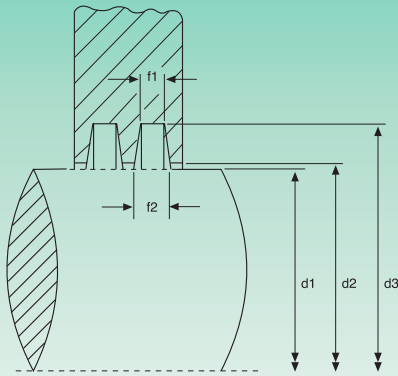

Obtención de laberinto "TS" para: SN-SD
"TS" labyrinth seal for: SN-SD

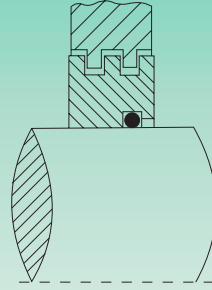

Obtención de taconite "TAC" para: SN-SD
"TAC" taconite cover for: SN-SD

Bul. fij. Bolt Size	Dimensiones - Dimensions				Peso Weight	Rodamiento autoalineable de rodillos (agujero cónico) Self-aligning roller bearing (conical bore)	Manguito (métrica) Adapter sleeve (metric)	Aro de centrado Locating ring		Tipo Type
	d2 H12	d3 H12	f1 H13	f2				Tipo Type	Cant. Q.ty	
S	mm				kg					
M 30	153	183	10	13,8	62	23034 K	H 3034	SR 260x10	1	SD 3034
M 30	163	193	10	13,8	78	23036 K	H 3036	SR 280x10	1	SD 3036
M 30	173	203	10	13,8	82	23038 K	H 3038	SR 290x10	1	SD 3038
M 30	183	213	10	13,8	92	23040 K	H 3040	SR 310x10	1	SD 3040
M 30	203	240	11	15,7	125	23044 K	H 3044	SR 340x10	1	SD 3044
M 30	223	260	11	15,7	140	23048 K	H 3048	SR 360x10	1	SD 3048
M 36	243	286	12	17,4	200	23052 K	H 3052	SR 400x10	1	SD 3052
M 36	263	306	12	17,4	230	23056 K	H 3056	SR 420x10	1	SD 3056
M 36	283	332	13	19,1	290	23060 K	H 3060	SR 460x10	1	SD 3060
M 36	303	352	13	19,1	300	23064 K	H 3064	SR 480x10	1	SD 3064
M 42	323	372	13	19,1	400	23068 K	H 3068	SR 520x10	1	SD 3068
M 42	343	392	13	19,1	450	23072 K	H 3072	SR 540x10	1	SD 3072
M 42	363	412	13	19,1	470	23076 K	H 3076	SR 560x10	1	SD 3076

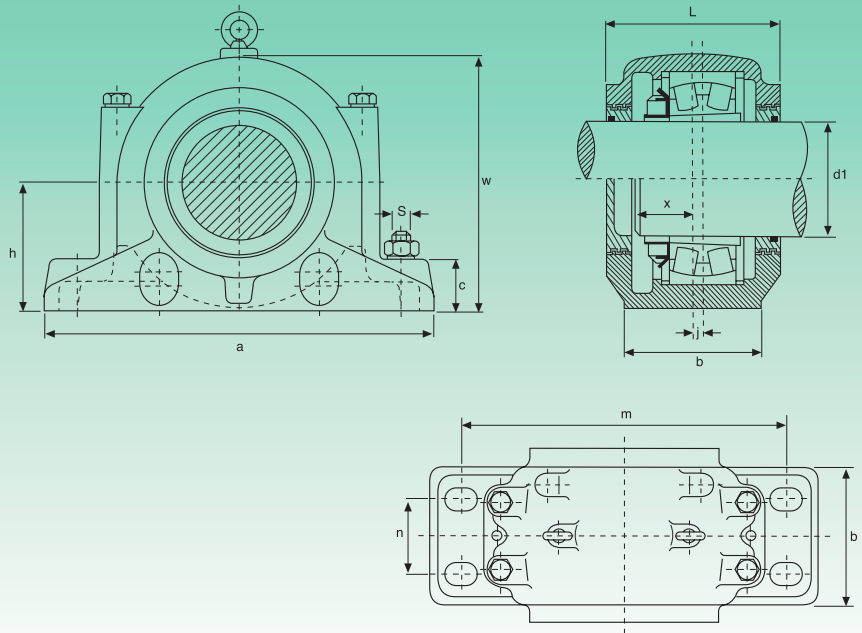

Tipo Type	Diámetro eje Shaft diameter		Dimensiones - Dimensions												
	d1		D H8	a	b	c	g H12	h h12	L ± 5	L2	w	m	n	U	U
	mm	inch													
SD 3134	150	6	280	510	180	70	108	170	230	308	335	430	100	30	36
SD 3136	160	6½	300	530	190	75	116	180	240	318	355	450	110	30	36
SD 3138	170	6¾	320	560	210	80	124	190	260	336	375	480	120	30	38
SD 3140	180	7	340	610	230	85	132	210	280	356	410	510	130	35	40
SD 3144	200	-	370	640	240	90	140	220	290	368	435	540	140	35	40
SD 3148	220	-	400	700	260	95	148	240	310	388	475	600	150	35	40
SD 3152	240	-	440	770	280	100	164	260	320	400	515	650	160	40	48
SD 3156	260	-	460	790	280	105	166	280	320	400	550	670	160	42	50
SD 3160	280	-	500	830	310	110	180	300	350	426	590	710	190	42	60
SD 3164	300	-	540	880	330	115	196	320	370	448	630	750	200	42	60
SD 3168	320	-	580	965	380	120	210	340	390	488	670	840	240	49	59
SD 3172	340	-	600	1040	390	130	212	360	390	498	720	890	255	49	59
SD 3176	360	-	620	1120	400	135	214	380	405	520	750	980	255	60	72
SD 3180	380	-	650	1245	420	140	220	400	425	543	790	1050	270	65	78

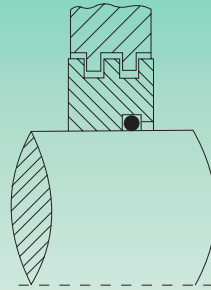
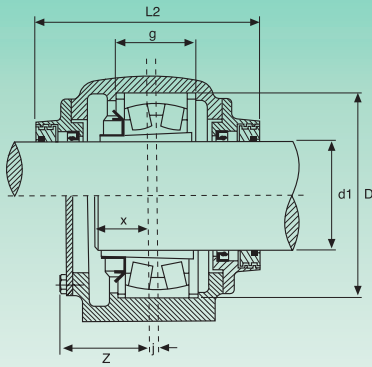

Obturación de laberinto "TS" para: SN-SD
"TS" labyrinth seal for: SN-SD

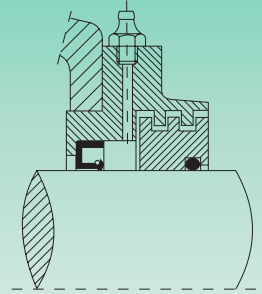

Obturación de taconite "TAC" para: SN-SD
"TAC" taconite cover for: SN-SD

Dimensiones - Dimensions			Bul. fj. Bolt Size	Peso Weight	Rodamiento autoalineable de rodillos (agujero cónico) Self-aligning roller bearing (conical bore)	Manguito Adapter sleeve		Aro de centrado Locating ring		"TS" Obturación de laberinto Labyrinth seal	"TAC" Obturación de taconite Taconite cover	Tipo Type
J	X	Z				S	mm	inch	Tipo Type			
mm				kg								
14	65	120	M 24	70	23134 K	H 3134	HE 3134	SR 280x10	2	TS 3134	TAC 3134	SD 3134
15	68	130	M 24	72	23136 K	H 3136	HE 3136	SR 300x10	2	TS 3136	TAC 3136	SD 3136
10	80	140	M 24	88	23138 K	H 3138	HE 3138	SR 320x10	2	TS 3138	TAC 3138	SD 3138
10	82	150	M 30	122	23140 K	H 3140	HE 3140	SR 340x10	2	TS 3140	TAC 3140	SD 3140
12	90	155	M 30	136	23144 K	H 3144	-	SR 370x10	2	TS 3144	TAC 3144	SD 3144
12	100	160	M 30	190	23148 K	H 3148	-	SR 400x10	2	TS 3148	TAC 3148	SD 3148
13	105	170	M 36	238	23152 K	H 3152	-	SR 440x10	2	TS 3152	TAC 3152	SD 3152
16	105	170	M 36	252	23156 K	H 3156	-	SR 460x10	2	TS 3156	TAC 3156	SD 3156
22	110	190	M 36	290	23160 K	H 3160	-	SR 500x10	2	TS 3160	TAC 3160	SD 3160
23	120	200	M 36	340	23164 K	H 3164	-	SR 540x10	2	TS 3164	TAC 3164	SD 3164
25	135	220	M 45	430	23168 K	H 3168	-	SR 580x10	2	TS 3168	TAC 3168	SD 3168
22	145	225	M 50	560	23172 K	H 3172	-	SR 600x10	2	TS 3172	TAC 3172	SD 3172
22	145	240	M 55	770	23176 K	H 3176	-	SR 620x10	2	TS 3176	TAC 3176	SD 3176
22	150	260	M 60	870	23180 K	H 3180	-	SR 650x10	2	TS 3180	TAC 3180	SD 3180

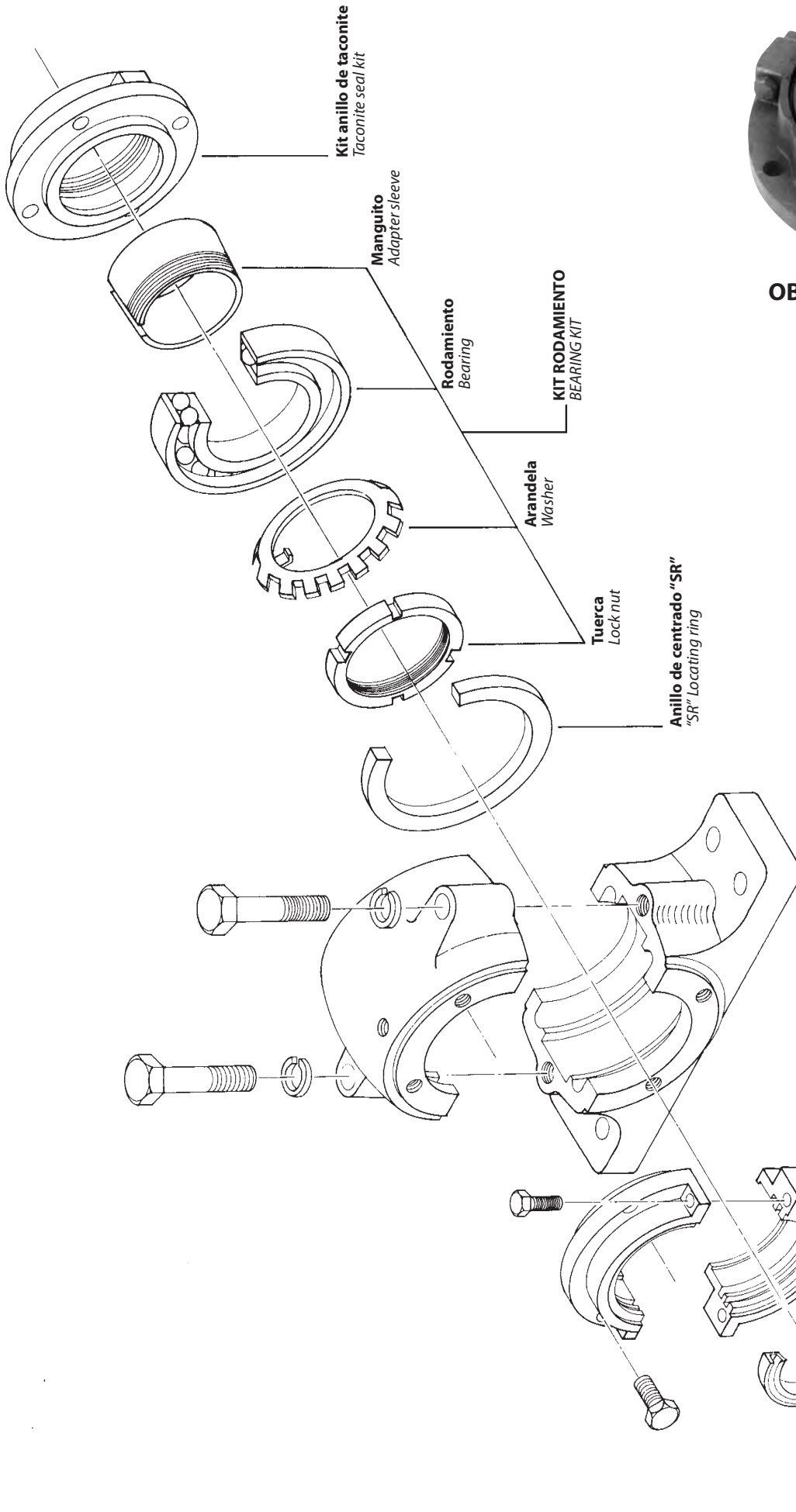

OBTURACIÓN DE TACONITE
TACONITE COVER

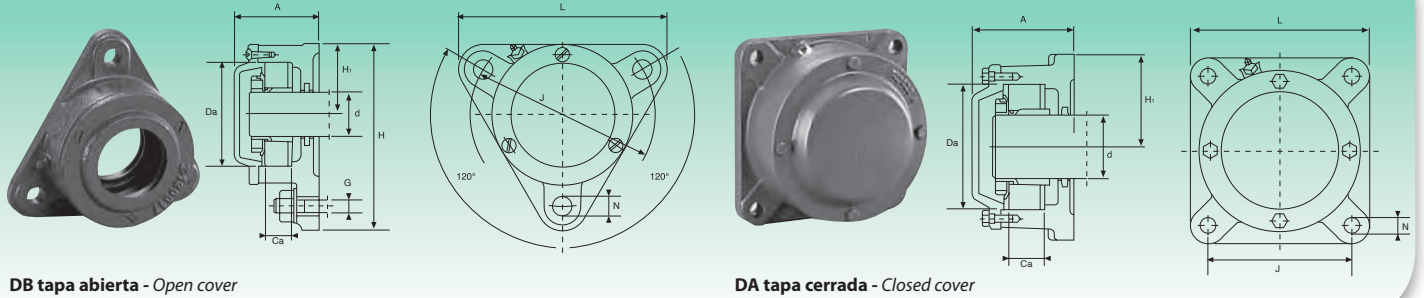

DB tapa abierta - Open cover

DA tapa cerrada - Closed cover

Tipo Type	Dimensiones - Dimensions										Peso Weigh kg	Rodamientos adecuados - Suitable bearings			Forma brida Flange
	d	A	L	H	H ₁	N	J	Da	Ca	G		Rodamientos de bolas autoalineables Self-aligning ball bearings	Rodamientos de rodillos autoalineables Cylindrical roller bearings		
	mm														
722505 DA	20	51,5	110	100	38	11,5	96	52	20	10	1,10	1205 K	2205 K	22205 K	▲
722505 DB	20	56,5	110	100	38	11,5	96	52	20	10	1,10	1205 K	2205 K	22205 K	▲
722506 DA	25	57	130	117	44	11,5	116	62	22	10	1,50	1206 K	2206 K	22206 K	▲
722506 DB	25	59,5	130	117	44	11,5	116	62	22	10	1,50	1206 K	2206 K	22206 K	▲
722507 DA	30	59,5	145	129,5	48,5	14	130	72	25	12	1,80	1207 K	2207 K	22207 K	▲
722507 DB	30	63,5	145	129,5	48,5	14	130	72	25	12	1,80	1207 K	2207 K	22207 K	▲
722508 DA	35	64	160	143	54	14	140	80	25	12	2,30	1208 K	2208 K	22208 K	▲
722508 DB	35	65,5	160	143	54	14	140	80	25	12	2,30	1208 K	2208 K	22208 K	▲
722509 DA	40	64,5	180	160	60	14	160	85	25	12	3,0	1209 K	2209 K	22209 K	▲
722509 DB	40	69,5	180	160	60	14	160	85	25	12	3,0	1209 K	2209 K	22209 K	▲
722510 DA	45	68,5	180	160	60	14	160	90	25	12	3,0	1210 K	2210 K	22210 K	▲
722510 DB	45	73	180	160	60	14	160	90	25	12	3,0	1210 K	2210 K	22210 K	▲
722511 DA	50	75,5	192	172,5	65	14	170	100	27	12	4,10	1211 K	2211 K	22211 K	▲
722511 DB	50	81,5	192	172,5	65	14	170	100	27	12	4,10	1211 K	2211 K	22211 K	▲
722512 DA	55	77	210	189	72	14	180	110	30	12	4,80	1212 K	2212 K	22212 K	▲
722512 DB	55	82	210	189	72	14	180	110	30	12	4,80	1212 K	2212 K	22212 K	▲
722513 DA	60	80	225	203	78	14	190	120	33	12	5,90	1213 K	2213 K	22213 K	▲
722513 DB	60	86	225	203	78	14	190	120	33	12	5,90	1213 K	2213 K	22213 K	▲
722515 A	65	104	190	190	95	18	152	130	41	16	9,40	1215 K	2215 K	22215 K	■
722515 B	65	104	190	190	95	18	152	130	41	16	9,40	1215 K	2215 K	22215 K	■
722516 A	70	110	196	196	98	18	152	140	43	16	9,80	1216 K	2216 K	22216 K	■
722516 B	70	110	196	196	98	18	152	140	43	16	9,80	1216 K	2216 K	22216 K	■
722517 A	75	114	210	210	105	18	170	150	46	16	11,5	1217 K	2217 K	22217 K	■
722517 B	75	114	210	210	105	18	170	150	46	16	11,5	1217 K	2217 K	22217 K	■
722518 A	80	118	210	210	105	18	170	160	50	16	12,5	1218 K	2218 K	22218 K	■
722518 B	80	118	210	210	105	18	170	160	50	16	12,5	1218 K	2218 K	22218 K	■
722520 A	90	127	250	250	125	22	198	180	56	20	18,0	1220 K	2220 K	22220 K	■
722520 B	90	127	250	250	125	22	198	180	56	20	18,0	1220 K	2220 K	22220 K	■
722522 A	100	137	270	270	135	22	219	200	63	20	21,5	1222 K	2222 K	22222 K	■
722522 B	100	137	270	270	135	22	219	200	63	20	21,5	1222 K	2222 K	22222 K	■

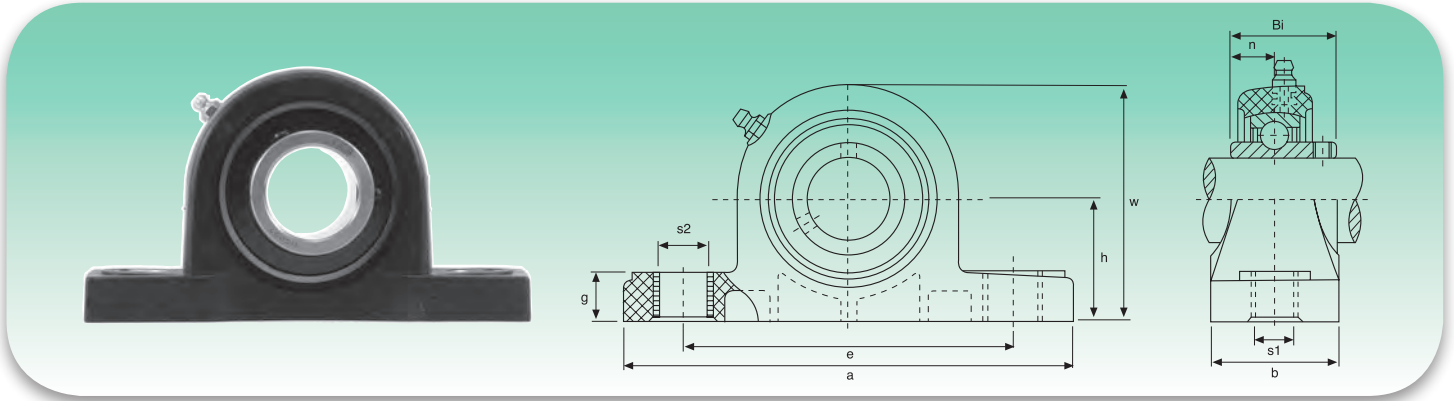

Tipo Type	Diámetro eje Shaft diameter		Dimensiones - Dimensions										Peso Weight kg	Bul. fij. Bolt Size	Torque (Nm) Torque (Nm)
			a	h	e	b	s1	s2	g	w	Bi	n			
	mm	inch	mm												
UCP 201	12	1/2	127	33,3	95	38	11	14	14,2	65	31	12,7	0,13	M10	18
UCP 202	15	9/16 5/8	127	33,3	95	38	11	14	14,2	65	31	12,7	0,13	M10	18
UCP 203	17	11/16	127	33,3	95	38	11	14	14,2	65	31	12,7	0,13	M10	18
UCP 204	20	3/4	127	33,3	95	38	11	14	14,2	65,5	31	12,7	0,13	M10	18
UCP 205	25	13/16 7/8 15/16 1	140,5	36,5	105	38	11	14	14,5	71	34	14,3	0,14	M10	25
UCP 206	30	11/16 11/8 13/16 1 1/4	163	42,9	119	46	14	18	17,8	84	38,1	15,9	0,24	M12	30
UCP 207	35	1 1/4 15/16 13/8 17/16	168	47,6	127	48	14	18	18	94,5	42,9	17,5	0,27	M12	35
UCP 208	40	1 1/2 19/16	184	49,2	137	54	14	18	19,5	101	49,2	19	0,35	M12	45
UCP 209	45	15/8 111/16 1 3/4	192	54	146	54	17	20	23	106	49,2	19	0,41	M16	50
UCP 210	50	113/16 17/8 115/16 2	206	57,2	159	60	17	20	23	114	51,6	19	0,47	M16	55
UCP 211	55	2 21/16 21/8 23/16	219	63,5	171	60	20	23	23	125	55,6	22,2	-	M16	60
UCP 212	60	2 1/4 25/16 23/8 27/16	241	69,8	184	70	20	23	25	138	65,1	25,4	-	M16	65

Modalidad de carga Mode of load	Coeficientes de carga (N) - Load ratings (N)									
	Tipo Type	204	205	206	207	208	209	210	211	212
		8 800	13 700	12 650	12 750	13 100	13 360	13 850	14 540	15 270
		7 700	10 000	10 600	10 800	11 100	11 400	11 750	11 970	12 570
		5 000	8 100	5 750	7 500	8 500	8 950	9 550	10 027	10 530

Características

- Material: PBT (disponibles en color blanco, negro y verde)
- Intercambiable con soportes de fundición
- Engrasadores galvanizados o de acero
- Temperatura de servicio: de -35 a +102
- Tapa extremo
- Obturaciones interiores
- Resistencia química (pág. 156)

Characteristics

- Material: PBT (white, black and green colours available)
- Interchangeable with cast iron housing
- Galvanized or steel greasers
- Working temperature: from -35°C to +102°C
- End cover
- Back seals
- Chemical resistance (pag. 156)

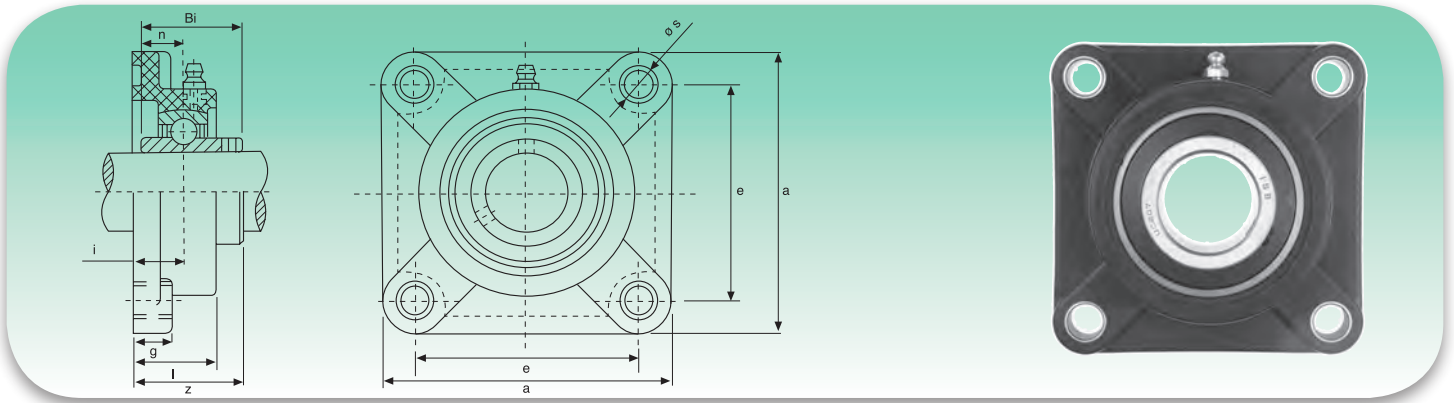

Tipo Type	Diámetro eje Shaft diameter		Dimensiones - Dimensions									Peso Weight	Bul. fij. Bolt Size	Torque (Nm) Torque (Nm)
			a	e	g	l	s	z	i	Bi	n			
	mm	inch	mm									kg		
UCF 201	12	1/2	86	63,5	13,4	27,8	11	34,6	16,3	31	12,7	0,12	M10	18
UCF 202	15	9/16 5/8	86	63,5	13,4	27,8	11	34,6	16,3	31	12,7	0,12	M10	18
UCF 203	17	11/16	86	63,5	13,4	27,8	11	34,6	16,3	31	12,7	0,12	M10	18
UCF 204	20	3/4	86	63,5	13,4	27,8	11	34,6	16,3	31	12,7	0,12	M10	18
UCF 205	25	13/16 7/8 15/16 1	95	70	14,3	28,5	11	36,7	17	34	14,3	0,15	M10	25
UCF 206	30	11/16 11/8 13/16 1 1/4	107	83	14,3	31,5	11	41,2	19	38,1	15,9	0,18	M10	30
UCF 207	35	1 1/4 15/16 13/8 17/16	118	92	15,5	34,5	13	46,9	21,5	42,9	17,5	0,25	M12	35
UCF 208	40	1 1/2 19/16	130	102	17	36,5	14	53,2	23	49,2	19	0,36	M12	40
UCF 209	45	15/8 111/16 1 3/4	137	105	19	41	17	54,2	24	49,2	19	0,42	M16	45
UCF 210	50	113/16 17/8 115/16 2	143	111	21	43	17	57,6	25	51,6	19	0,49	M16	50
UCF 211	55	21/16 21/8 23/16	162	130	20	43	19	63	25	55,6	22,2	-	M16	55
UCF 212	60	2 1/4 25/16 23/8 27/16	175	143	20	48	19	73,5	29	65,1	25,4	-	M16	60

Modalidad de carga Mode of load	Coeficientes de carga (N) - Load ratings (N)									
	Tipo Type	204	205	206	207	208	209	210	211	212
		15 950	13 000	18 000	18 500	19 100	19 350	19 650	20 630	21 660
		10 250	12 150	17 700	18 500	19 250	19 350	19 620	20 600	21 630
		3 650	3 350	3 350	3 520	3 790	3 850	3 990	4 190	4 400

Características

- Material: PBT (disponibles en color blanco, negro y verde)
- Intercambiable con soportes de fundición
- Engrasadores galvanizados o de acero
- Temperatura de servicio: de -35 a +102
- Tapa extremo
- Obturaciones interiores
- Resistencia química (pág. 156)

Characteristics

- Material: PBT (white, black and green colours available)
- Interchangeable with cast iron housing
- Galvanized or steel greasers
- Working temperature: from -35°C to +102°C
- End cover
- Back seals
- Chemical resistance (pag. 156)

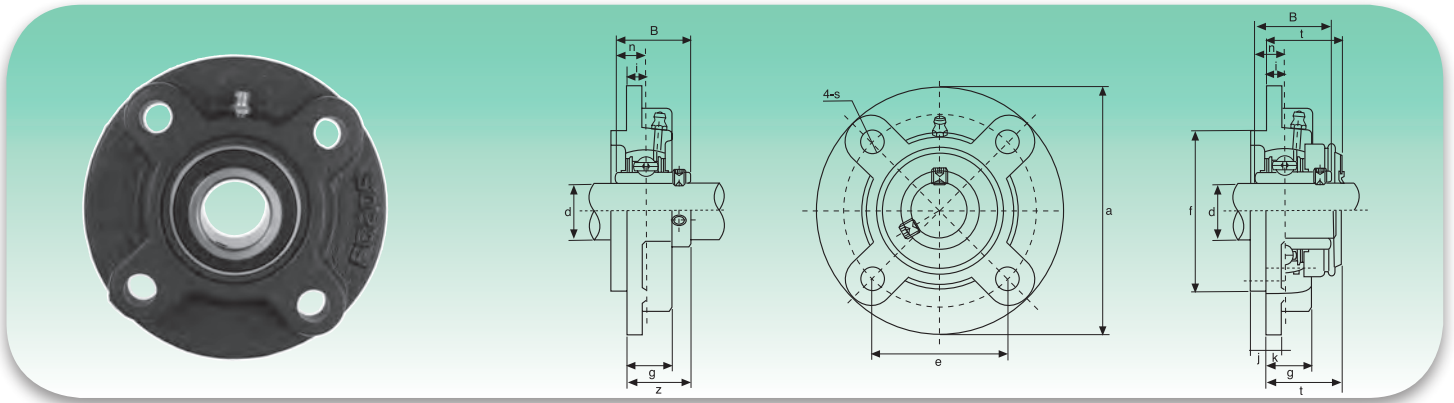
UCFC

Tipo Type	Diámetro eje Shaft diameter		Dimensiones - Dimensions								Peso Weight	Bul. fij. Bolt Size	Torque (Nm) Torque (Nm)
			a	e	g	s	z	i	Bi	n			
	mm	inch	mm										
UCFC 204	20	¾	100	55,1	20,5	12	28,3	10	31	12,7	0,14	M10	18
UCFC 205	25	13/16 7/8 15/16 1	115	63,6	21	12	29,7	10	34,1	14,3	0,19	M10	25
UCFC 206	30	11/16 11/8 13/16 1¼	125	70,7	23	12	32,2	10	38,1	15,9	0,26	M10	30
UCFC 207	35	1¼ 15/16 13/8 17/16	135	77,8	26	14	36,4	11	42,9	17,5	0,36	M12	35
UCFC 208	40	1½ 19/16	145	84,8	26	14	40,2	11	49,2	19	0,40	M12	40
UCFC 209	45	15/8 111/16 1¾	160	93,3	26	16	41,2	10	49,2	19	0,58	M14	45
UCFC 210	50	113/16 17/8 115/16 2	165	97,6	28	16	42,6	10	51,6	19	0,58	M14	50
UCFC 211	55	2 21/16 21/8 23/16	185	106,1	31	19	46,4	13	55,6	22,2	-	M16	55
UCFC 212	60	2¼ 25/16 25/8 27/16	195	113,1	36	19	56,7	17	65,1	25,4	-	M16	60

Modalidad de carga Mode of load	Coeficientes de carga (N) - Load ratings (N)								
Tipo Type	204	205	206	207	208	209	210	211	212
	15 950	13 000	18 000	18 500	19 100	19 350	19 650	20 630	21 660
	10 250	12 150	17 700	18 500	19 250	19 350	19 620	20 600	21 630

Características

- Material: PBT (**disponibles en color blanco, negro y verde**)
- Intercambiable con soportes de fundición
- Engrasadores galvanizados o de acero
- Temperatura de servicio: de -35 a +102
- Tapa extremo
- Obturaciones interiores
- Resistencia química (pág. 156)

Characteristics

- Material: PBT (**white, black and green colours available**)
- Interchangeable with cast iron housing
- Galvanized or steel greasers
- Working temperature: from -35°C to +102°C
- End cover
- Back seals
- Chemical resistance (pag. 156)

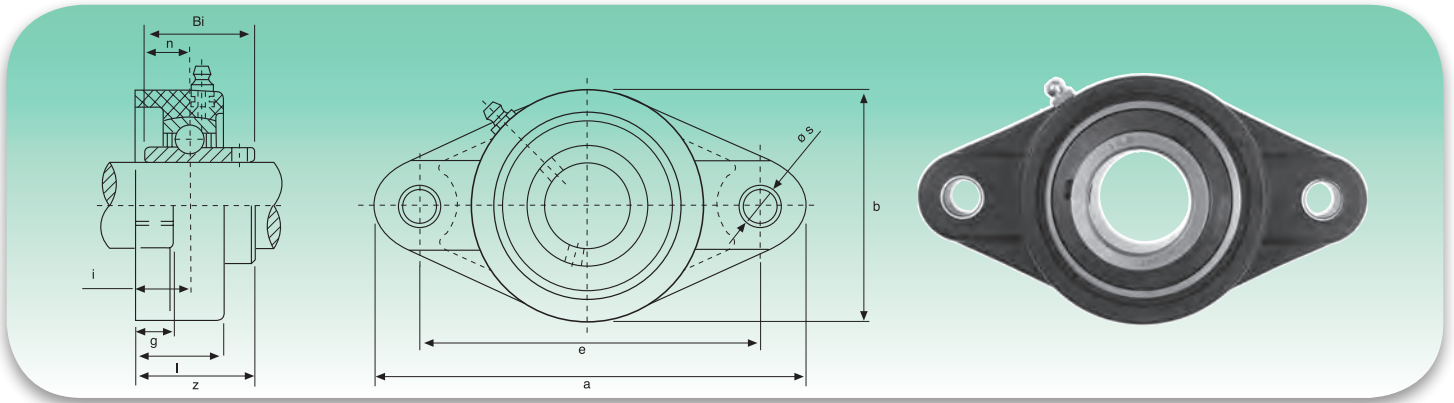

Tipo Type	Diámetro eje Shaft diameter		Dimensiones - Dimensions										Peso Weight	Bul. fj. Bolt Size	Torque (Nm) Torque (Nm)
			a	e	b	g	l	s	z	i	Bi	n			
	mm	inch	mm										kg		
UCFL 201	12	½	113	90	65	13,4	26,5	11	33,3	15	31	12,7	0,08	M10	18
UCFL 202	15	9/16 5/8	113	90	65	13,4	26,5	11	33,3	15	31	12,7	0,08	M10	18
UCFL 203	17	11/16	113	90	65	13,4	26,5	11	33,3	15	31	12,7	0,08	M10	18
UCFL 204	20	¾	113	90	65	13,4	26,5	11	33,3	15	31	12,7	0,08	M10	18
UCFL 205	25	13/16 7/8 15/16 1	131	99	70,5	14,3	28	11	36,2	16,5	34	14,3	0,11	M10	25
UCFL 206	30	11/16 11/8 13/16 1¼	148	117	80	14,3	30,5	11	40,2	18	38,1	15,9	0,13	M10	30
UCFL 207	35	1¼ 15/16 13/8 17/16	164	130	90	15,5	32	13	44,4	19	42,9	17,5	0,16	M12	35
UCFL 208	40	1½ 19/16	176	144	100	17	35	14	51,7	21,5	49,2	19	0,22	M12	40
UCFL 209	45	15/8 111/16 1¾	189	149	108	21	41	17	54,2	24	49,2	19	0,36	M16	45
UCFL 210	50	113/16 17/8 115/16 2	197	157	115	21	43	17	57,6	25	51,6	19	0,31	M16	50
UCFL 211	55	2 21/16 21/8 23/16	224	184	130	18	43	19	63	25	55,6	22,2	-	M16	55
UCFL 212	60	2¼ 25/16 25/8 27/16	250	202	140	18	48	23	73,5	29	65,1	25,4	-	M16	60

Modalidad de carga Mode of load	Coeficientes de carga (N) - Load ratings (N)									
Tipo Type	204	205	206	207	208	209	210	211	212	
	11 750	11 375	16 450	16 900	17 350	17 600	17 950	18 850	19 790	
	11 000	13 850	13 350	13 950	14 050	14 300	14 550	15 280	16 040	
	8 500	11 100	14 200	14 900	15 150	15 350	15 650	16 430	17 250	

Características

- Material: PBT (disponibles en color blanco, negro y verde)
- Intercambiable con soportes de fundición
- Engrasadores galvanizados o de acero
- Temperatura de servicio: de -35 a +102
- Tapa extremo
- Obturaciones interiores
- Resistencia química (pág. 156)

Characteristics

- Material: PBT (white, black and green colours available)
- Interchangeable with cast iron housing
- Galvanized or steel greasers
- Working temperature: from -35°C to +102°C
- End cover
- Back seals
- Chemical resistance (pag. 156)

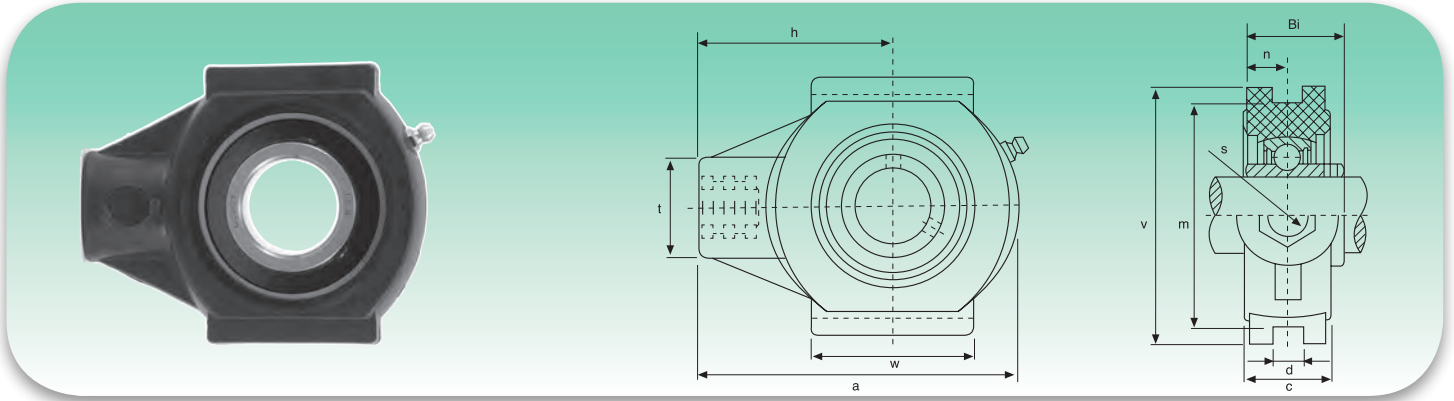
UCT

Tipo Type	Diámetro eje Shaft diameter		Dimensiones - Dimensions										Peso Weight	Bul. fj. Bolt Size
			a	c	d	h	m	t	v	w	Bi	n		
	mm	inch	mm										kg	S
UCT 201	12	½	99	27,5	12	64	76	36	88	47	31	12,7	0,18	M16
UCT 202	15	9/16 5/8	99	27,5	12	64	76	36	88	47	31	12,7	0,18	M16
UCT 203	17	11/16	99	27,5	12	64	76	36	88	47	31	12,7	0,18	M16
UCT 204	20	¾	99	27,5	12	64	76	36	88	47	31	12,7	0,18	M16
UCT 205	25	13/16 7/8 15/16 1	99	27,5	12	64	76	36	88	47	34	14,3	0,17	M16
UCT 206	30	11/16 11/8 13/16 1¼	125	34,5	12	76	89	40	102	63	38,4	15,9	0,28	M16
UCT 207	35	1¼ 15/16 13/8 17/16	125	34,5	12	76	89	40	102	63	42,9	17,5	0,27	M16
UCT 208	40	1½ 19/16	140	34,5	16	85	102	40	114	80	49,2	19	0,36	M16
UCT 209	45	15/8 111/16 1¼	149	40	16	90	102	50	117	85	49,2	19	0,41	M20
UCT 210	50	113/16 17/8 115/16 2	149	40	16	90	102	50	117	85	51,6	19	0,47	M20
UCT 211	55	2 21/16 21/8 23/16	171	38	22	106	130	64	146	95	55,6	22,2	-	M20
UCT 212	60	2¼ 25/16 23/8 27/16	194	42	22	119	130	64	146	102	65,1	25,4	-	M20

Modalidad de carga Mode of load	Coeficientes de carga (N) - Load ratings (N)									
Tipo Type	204	205	206	207	208	209	210	211	212	
	14 800	15 500	15 800	16 500	17 300	18 210	18 860	19 800	20 790	
	3 930	4 530	5 100	6 500	7 800	8 710	9 750	10 240	10 750	
	8 500	10 350	10 900	11 300	12 150	12 900	13 550	14 230	14 940	
	40 770	45 300	46 100	44 100	42 800	44 230	44 880	47 120	49 470	

Características

- Material: PBT (disponibles en color blanco, negro y verde)
- Intercambiable con soportes de fundición
- Engrasadores galvanizados o de acero
- Temperatura de servicio: de -35 a +102
- Tapa extremo
- Obturaciones interiores
- Resistencia química (pág. 156)

Characteristics

- Material: PBT (white, black and green colours available)
- Interchangeable with cast iron housing
- Galvanized or steel greasers
- Working temperature: from -35°C to +102°C
- End cover
- Back seals
- Chemical resistance (pag. 156)

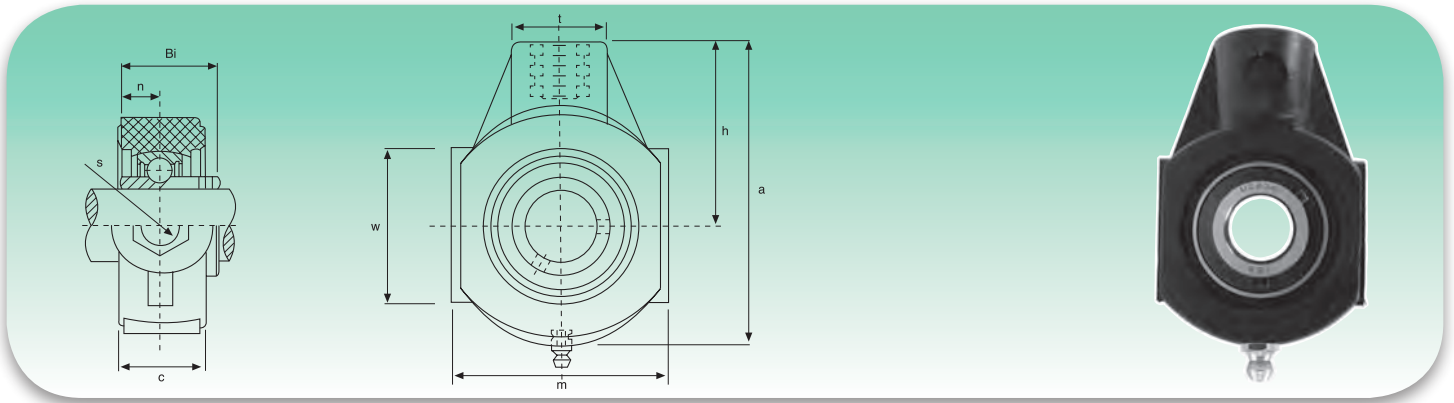

Tipo Type	Diámetro eje Shaft diameter		Dimensiones - Dimensions								Peso Weight	Bul. fij. Bolt Size
			a	c	h	m	t	w	Bi	n		
	mm	inch	mm								kg	S
UCECH 201	12	1/2	99	27,5	63,5	65	36	47	31	12,7	0,18	M16
UCECH 202	15	9/16 5/8	99	27,5	63,5	65	36	47	31	12,7	0,18	M16
UCECH 203	17	11/16	99	27,5	63,5	65	36	47	31	12,7	0,18	M16
UCECH 204	20	3/4	99	27,5	63,5	65	36	47	31	12,7	0,18	M16
UCECH 205	25	13/16 7/8 15/16 1	99	27,5	63,5	74	36	47	34	14,3	0,17	M16
UCECH 206	30	11/16 11/8 13/16 1 1/4	125	34,5	76	90	40	63	38,1	15,9	0,28	M16
UCECH 207	35	1 1/4 15/16 13/8 17/16	125	34,5	76	90	40	63	42,9	17,5	0,27	M16
UCECH 208	40	1 1/2 19/16	140	34,5	85	100	40	80	49,2	19	0,36	M16
UCECH 209	45	15/8 111/16 1 1/4	149	40	90	110	50	85	49,2	19	0,41	M20
UCECH 210	50	113/16 17/8 115/16 2	149	40	90	110	50	85	51,6	19	0,47	M20
UCECH 211	55	2 21/16 21/8 23/16	171	38	106	140	64	95	55,6	22,2	-	M20
UCECH 212	60	2 1/4 25/16 23/8 27/16	194	42	119	140	64	102	65,1	25,4	-	M20

Modalidad de carga Mode of load	Coeficientes de carga (N) - Load ratings (N)									
Tipo Type	204	205	206	207	208	209	210	211	212	
	14 800	15 500	15 800	16 500	17 300	18 210	18 860	19 800	20 790	
	3 930	4 530	5 100	6 500	7 800	8 710	9 750	10 240	10 750	
	8 500	10 350	10 900	11 300	12 150	12 900	13 550	14 230	14 940	
	40 770	45 300	46 100	44 100	42 800	44 230	44 880	47 120	49 470	

Características

- Material: PBT (disponibles en color blanco, negro y verde)
- Intercambiable con soportes de fundición
- Engrasadores galvanizados o de acero
- Temperatura de servicio: de -35 a +102
- Tapa extremo
- Obturaciones interiores
- Resistencia química (pág. 156)

Characteristics

- Material: PBT (white, black and green colours available)
- Interchangeable with cast iron housing
- Galvanized or steel greasers
- Working temperature: from -35°C to +102°C
- End cover
- Back seals
- Chemical resistance (pag. 156)

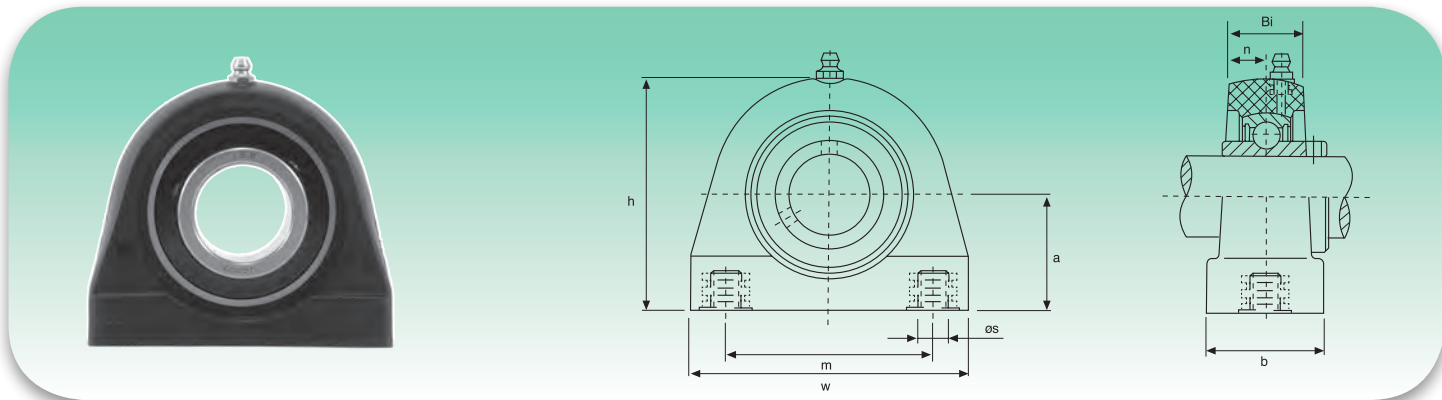
UCPA

Tipo Type	Diámetro eje Shaft diameter		Dimensiones - Dimensions							Peso Weight	Bul. fij. Bolt Size	Torque (Nm) Torque (Nm)
			a	b	h	m	w	Bi	n			
	mm	inch	mm							kg	S	
UCPA 201	12	½	33,3	34,5	66	50,8	72,8	31	12,7	0,085	M8	18
UCPA 202	15	9/16 5/8	33,3	34,5	66	50,8	72,8	31	12,7	0,085	M8	18
UCPA 203	17	11/16	33,3	34,5	66	50,8	72,8	31	12,7	0,085	M8	18
UCPA 204	20	¾	33,3	34,5	66	50,8	72,8	31	12,7	0,085	M8	18
UCPA 205	25	13/16 7/8 15/16 1	36,5	39,5	73,5	50,8	76,2	34,1	14,3	0,115	M10	25
UCPA 206	30	11/16 11/8 13/16 1¼	42,9	42,5	84	76,2	101	38,1	15,9	0,17	M10	30
UCPA 207	35	1¼ 15/16 13/8 17/16	47,6	47,5	95	82,6	110	42,9	17,5	0,28	M10	35
UCPA 208	40	1½ 19/16	49,2	48	100,5	88,9	120	49,2	19	0,39	M12	45
UCPA 209	45	15/8 111/16 1¾	54	50	108,5	95,3	124	49,2	19	0,47	M12	50
UCPA 210	50	113/16 17/8 115/16 2	57,2	54	115	101,6	135	51,6	19	0,56	M16	55
UCPA 211	55	2 21/16 21/8 23/16	140	66	63,5		125	55,6	22,2	1,43	M20	60
UCPA 212	60	2¼ 25/16 25/8 27/16	150	68	69,9		138	65,1	25,4	1,58	M20	65

Modalidad de carga Mode of load	Coeficientes de carga (N) - Load ratings (N)									
Tipo Type	204	205	206	207	208	209	210	211	212	
	8 210	8 540	10 370	12 150	12 230	12 900	13 850	14 540	15 270	
	6 900	7 010	6 580	8 080	9 100	10 400	11 050	11 600	12 180	
	2 980	2 850	4 950	8 160	9 800	10 710	11 360	11 930	12 530	

Características

- Material: PBT (**disponibles en color blanco, negro y verde**)
- Intercambiable con soportes de fundición
- Engrasadores galvanizados o de acero
- Temperatura de servicio: de -35 a +102
- Tapa extremo
- Obturaciones interiores
- Resistencia química (pág. 156)

Characteristics

- Material: PBT (**white, black and green colours available**)
- Interchangeable with cast iron housing
- Galvanized or steel greasers
- Working temperature: from -35°C to +102°C
- End cover
- Back seals
- Chemical resistance (pag. 156)

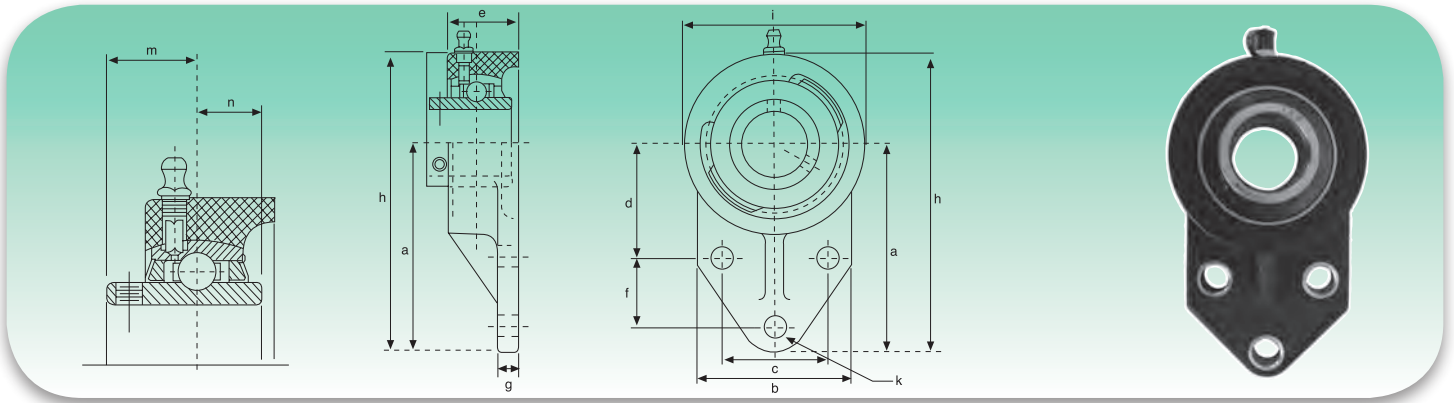

Tipo Type	Diámetro eje Shaft diameter		Dimensiones - Dimensions											Peso Weight	Bul. fij. Bolt Size	Torque (Nm) Torque (Nm)	
			a	b	c	d	e	f	g	h	i	k	m				n
	mm	inch	mm											kg			
UCFB 201	12	½	76,2	62	38,1	42,9	33,7	22,2	11,4	108	63,5	10,7	18,3	12,7	0,08	M10	18
UCFB 202	15	9/16 5/8	76,2	62	38,1	42,9	33,7	22,2	11,4	108	63,5	10,7	18,3	12,7	0,08	M10	18
UCFB 203	17	11/16	76,2	62	38,1	42,9	33,7	22,2	11,4	108	63,5	10,7	18,3	12,7	0,08	M10	18
UCFB 204	20	¾	76,2	62	38,1	42,9	33,7	22,2	11,4	108	63,5	10,7	18,3	12,7	0,08	M10	18
UCFB 205	25	13/16 7/8 15/16 1	85,7	63,5	41,3	46	35,2	28,6	11,4	120,6	70	10,7	19,7	14,3	0,11	M10	25
UCFB 206	30	11/16 11/8 13/16 1¼	96,5	76	47,6	52,4	41,5	31,8	13,3	138,5	83	10,7	22,2	15,9	0,16	M10	30
UCFB 207	35	1¼ 15/16 13/8 17/16	109,5	89	50,8	60,3	47,1	31,8	16,1	157	95	13,1	25,4	17,5	0,23	M12	35
UCFB 208	40	1½ 19/16	-	78	50	60	36	41	16	164	100	13,1	30,2	19	0,78	M12	40
UCFB 209	45	15/8 111/16 12/4	-	80	54	65	38	43	18	174	106	13,1	30,2	19	0,92	M12	45
UCFB 210	50	113/16 17/8 115/16 2	-	86	58	68	40	46	18	184	112	13,1	32,6	19	1,12	M12	50
UCFB 211	55	2 21/16 21/8 23/16	-	90	62	78	43	50	18	207	130	16	33,4	22,2	-	M14	55
UCFB 212	60	2¼ 25/16 25/8 27/16	-	94	66	84	48	55	18	223	140	16	39,7	25,4	-	M14	60

Modalidad de carga Mode of load	Coeficientes de carga (N) - Load ratings (N)									
Tipo Type	201	202	203	204	205	206	207	211	212	
	-	-	-	7 200	9 100	12 200	12 900	13 540	14 200	
	-	-	-	9 200	11 100	11 800	11 900	12 500	13 120	
	-	-	-	2 600	2 800	2 900	3 100	3 250	3 410	

Características

- Material: PBT (disponibles en color blanco, negro y verde)
- Intercambiable con soportes de fundición
- Engrasadores galvanizados o de acero
- Temperatura de servicio: de -35 a +102
- Tapa extremo
- Obturaciones interiores
- Resistencia química (pág. 156)

Characteristics

- Material: PBT (white, black and green colours available)
- Interchangeable with cast iron housing
- Galvanized or steel greasers
- Working temperature: from -35°C to +102°C
- End cover
- Back seals
- Chemical resistance (pag. 156)

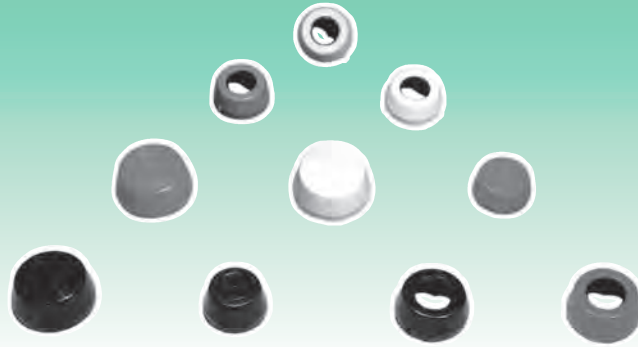
Características

- Material: Polipropileno (SR 50)
- Aprobado FDA
- Tapa abierta con anillo de acero inox
- Gama colores a petición

Characteristics

- Material: Polypropylen (SR 50)
- FDA approved
- Open cover with stainless steel ring
- Range of colours on request

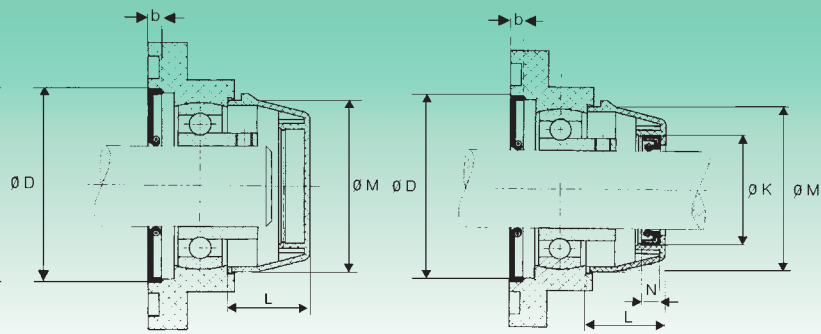

Diámetro eje Shaft diameter		Dimensiones - Dimensions					
		K	N	L	M	D	B
mm	inch	mm					
12	½	32	7	23	50	52	6
15	9/16 5/8	32	7	23	50	52	6
17	11/16	32	7	23	50	52	6
20	¾	32	7	23	50	52	6
25	13/16 7/8 15/16 1	37	7	25	55	62	6
30	11/16 11/8 13/16 1¼	42	7	30	64	72	6
35	1¼ 15/16 13/8 17/16	47	7	32	74,5	82	6
40	1½ 19/16	52	7	37	84	88	6
45	15/8 111/16 1¾	57	7	41	89	93	6
50	113/16 17/8 115/16 2	62	7	47	94	98	6

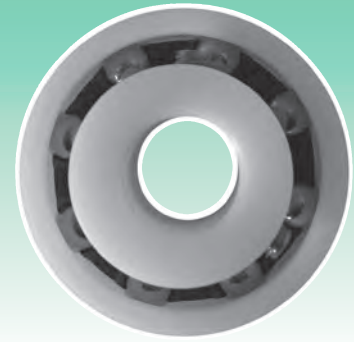
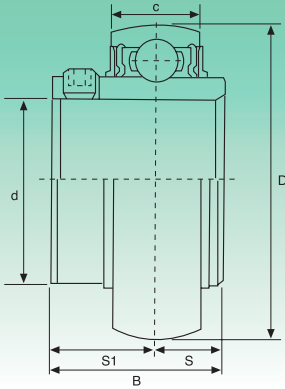

Tipo Type	Dimensiones - Dimensions						Carga Kg. rodamiento (daN) (Kp) Rating load bearing (daN) (Kp)		Velocidad rpm máx./mín. Speed max. r.p.m.	Peso Weight kg
	d	D	B	C	S ₁	S	Dinámico Dynamic	Estático Static		
	mm/inch									
UC 200	10 ¾	47 1,8504	31 1,2205	17 0,6693	18,3 0,720	12,7 0,500	42	27	1050	0,30
UC 201-8	¾	1,8504	1,2205	0,6693	0,720	0,500				
UC 202	15	47	31	17	18,3	12,7	42	27	1050	0,30
UC 202-9	9/16	1,8504	1,2205	0,6693	0,720	0,500				
UC 202-10	5/8	1,8504	1,2205	0,6693	0,720	0,500				
UC 203	17	47	31	17	18,3	12,7	42	27	1050	0,30
UC 203-11	11/16	1,8504	1,2205	0,6693	0,720	0,500				
UC 204	20	47	31	17	18,3	12,7	42	27	1050	0,30
UC 204-12	¾	1,8504	1,2205	0,6693	0,720	0,500				
UC 205	25	52	34,1	17	19,8	14,3	48	32	950	0,46
UC 205-13	13/16									
UC 205-14	7/8	2,0472	1,3425	0,6693	0,780	0,563				
UC 205-15	15/16									
UC 205-16	1									
UC 206	30	62	38,1	19	22,2	15,9	55	36	800	0,69
UC 206-17	11/16									
UC 206-18	11/8	2,4409	1,5000	0,7480	0,874	0,626				
UC 206-19	13/16									
UC 206-20	1¼									
UC 207	35	72	42,9	20	25,4	17,5	62	41	700	0,89
UC 207-20	1¼									
UC 207-21	15/16	2,8346	1,6890	0,7874	1,000	0,689				
UC 207-22	13/8									
UC 207-23	17/16									
UC 208	40	80	49,2	22	30,2	19	66	44	625	1,08
UC 208-24	1½	3,1496	1,9370	0,8661	1,189	0,748				
UC 208-25	19/16									

Disponible también:

Rodamientos de bolas de acero inox (AISI 440C)

Rodamientos de bolas de acero (Cromo 100CR6 - SAE 52100)

Para conocer las medidas y las cargas véase la página 102

Los rodamientos son de tipo abierto en la versión estándar. Están también disponibles con protección simple y doble. Los valores expuestos en la tabla anterior se refieren a rodamientos de bolas con aros de resina acetálica (POM).

Available also:

Stainless steel bearings (AISI 440C)

Chrome steel bearings (Chrome 100CR6 - SAE 52100)

For size and load see page 102

In standard version, the bearing are open, but can also be supplied in one or double shield version. The load capacities and speed limits stated in the table above, apply only to ball bearings with ring of polyacetal (POM).

SA

Sufijo UNF: Medidas en pulgadas de los pasadores de fijación
UNF suffix: inch sizes set screws

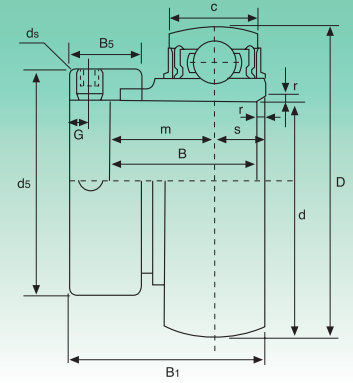

Tipo Type	Dimensiones - Dimensions												Carga Kg. rodamiento (daN) (Kp) Rating load bearing (daN) (Kp)		Peso Weight kg
	d	c	D	B	r	s	m	B ₁	d _s	B _s	G	d _s	Dinámico Dynamic	Estático Static	
	mm/inch														
SA 204	20	14	47	21,5	1,5	7	14,5	31	33,3	13,5	5	M6x0,75	60,6	37,8	0,10
SA 204-12	¾	0,5512	1,8504	0,8465	0,0591	0,2756	0,5709	1,2205	1,3110	0,5315	0,1969	-			
SA 205	25	15	52	21,5	1,5	7,5	14	31	38,1	13,5	5	M6x0,75	66	42,6	0,11
SA 205-13	13/16	0,5906	2,0472	0,8465	0,0591	0,2953	0,5512	1,2205	1,5000	0,5315	0,1969	-			
SA 205-14	7/8														
SA 205-15	15/16														
SA 205-16	1														
SA 206	30												16	62	23,8
SA 206-17	11/16	0,6299	2,4409	0,9370	0,0591	0,3150	0,6220	1,4055	1,7520	0,6260	0,2362	M8x1			
SA 206-18	11/8														
SA 206-19	13/16														
SA 206-20	1¼														
SA 207	35												17	72	25,4
SA 207-20	1¼	0,6693	2,8346	1,000	0,0787	0,3346	0,6654	1,5315	2,1890	0,6890	0,2560	M8x1			
SA 207-21	15/16														
SA 207-22	13/8														
SA 207-23	17/16														
SA 208	40												19	80	30,2
SA 208-24	1½	0,7480	3,1496	1,1890	0,0787	0,3740	0,8346	1,7205	2,3740	0,7205	0,2560	M8x1			
SA 208-25	19/16														
SA 209	45												19	85	30,2
SA 209-26	15/8	0,7480	3,3465	1,1890	0,0787	0,3740	0,8150	1,7205	2,5000	0,7205	0,2560	M8x1			
SA 209-27	111/16														
SA 209-28	1¾														
SA 210	50												20	90	30,2
SA 210-29	113/16	0,7874	3,5433	1,1890	0,0787	0,3937	0,8346	1,7205	2,7520	0,7205	0,2560	-			
SA 210-30	17/8														
SA 210-31	115/16														
SA 210-32	2														

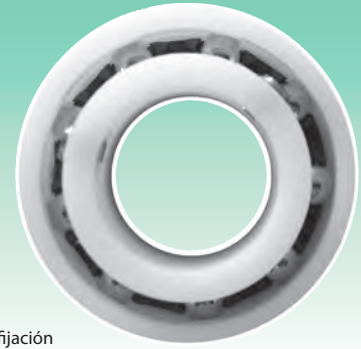
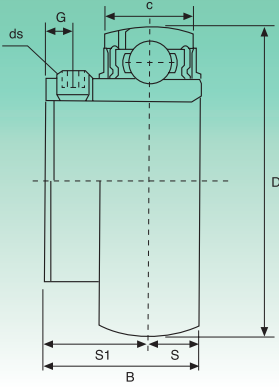

Sufijo UNF: Medidas en pulgadas de los pasadores de fijación
UNF suffix: inch sizes set screws

Tipo Type	Dimensiones - Dimensions								Carga Kg. rodamiento (daN) (Kp) Rating load bearing (daN) (Kp)		Peso Weight kg
	d	c	D	B	s	S ₁	G	ds	Dinámico Dynamic	Estático Static	
	mm/inch										
SB 204	20	14	47	25	7	18	4,5	M6x0,75	60,6	37,8	0,08
SB 204-12	¾	0,5512	1,8504	0,9843	0,2756	0,7087	0,1772	-			
SB 205	25	15	52	27	7,5	19,5	5	M6x0,75	66	42,6	0,10
SB 205-13	13/16	0,5906	2,0472	1,0630	0,2953	0,7677	0,1969	-			
SB 205-14	7/8										
SB 205-15	15/16										
SB 205-16	1										
SB 206	30								16	62	30
SB 206-17	11/16	0,6299	2,4409	1,1811	0,3150	0,8661	0,2165	-			
SB 206-18	11/8										
SB 206-19	13/16										
SB 206-20	1¼										
SB 207	35								17	72	32
SB 207-20	1¼	0,6693	2,8346	1,2598	0,3346	0,9252	0,2362	5/16 24 UNF			
SB 207-21	15/16										
SB 207-22	13/8										
SB 207-23	17/16										
SB 208	40								19	80	34
SB 208-24	1½	0,7480	3,1496	1,3386	0,3740	0,9843	0,3150	5/16 24 UNF			
SB 208-25	19/16										
SB 209	45	19	85	41,2	10,2	31	8	M8x1	154,2	108,6	0,48
SB 209-26	15/8	0,7480	3,3465	1,6220	0,4016	1,2205	0,3150	5/16 24 UNF			
SB 209-27	111/16										
SB 209-28	1¾										
SB 210	50								20	90	43,5
SB 210-29	113/16	0,7874	3,5433	1,7126	0,4291	1,2835	0,3543	-			
SB 210-30	17/8										
SB 210-31	115/16										
SB 210-32	2										

Propiedades típicas del PBT
Typical properties of PBT

Propiedades mecánicas <i>Mechanicals properties</i>	Unidad <i>Unit</i>	Método para el test <i>Method test</i>	Valores <i>Value</i>
Resistencia a la tracción antes de la deformación antes de la rotura <i>Tensile strenght at yield at break</i>	N/mm ² N/mm ²	ASTM D 638 ASTM D 638	115 -
<i>Tensile strenght at yield at break</i>	N/mm ² N/mm ²	ASTM D 638 ASTM D 638	115 -
Alargamiento relativo antes de la deformación antes de la rotura <i>Elongation at yield at break</i>	% %	ASTM D 638 ASTM D 638	3 -
<i>Elongation at yield at break</i>	% %	ASTM D 638 ASTM D 638	3 -
Módulo elástico por tracción <i>Tensile modulus</i>	N/mm ² N/mm ²	ASTM D 638 ASTM D 638	8000 8000
Resistencia a la flexión antes de la deformación <i>Flexural yield strenght</i>	N/mm ² N/mm ²	ASTM D 790 ASTM D 790	170 170
Módulo de rigidez flexional <i>Flexural modulus</i>	N/mm ² N/mm ²	ASTM D 790 ASTM D 790	7000 7000
Resistencia al choque con ranurado Charpy <i>Notched impact strenght Charpy</i>	K/m ² K/m ²	DIN 53453 DIN 53453	12 12
Resistencia al choque con ranurado IZOD <i>Notched impact strenght IZOD</i>	N/mm ² N/mm ²	ASTM D 256 ASTM D 256	100 100
Dureza <i>Hardness</i> H358/10 H358/60 Rockwell	N/mm ² N/mm ² N/mm ²	DIN 53456 DIN 53456 ASTM D 785	140 101 L102

Propiedades térmicas <i>Thermal properties</i>	Unidad <i>Unit</i>	Método para el test <i>Method test</i>	Valores <i>Value</i>
Coefficiente de oxígeno <i>Oxygen index</i>	% %	ASTM D 2863 ASTM D 2863	19 19
Retardancia a la llama (1/6 mm espesor) <i>Flame retardancy (1/6 mm thickness)</i>	- -	UL stand 94 UL stand 94	94HB 94HB
Resistencia al calor: Vicat, Método B <i>Heat resistance: Vicat, Method B</i>	°C °C	ASTM D 1525 ASTM D 1525	210-215 210-215
Conductividad térmica <i>Thermal conductivity</i>	W/m ² C W/m ² C	ASTM C 177 ASTM C 177	0,19 0,19
Flujo de contracción del módulo <i>Modul shrinkage flow</i>	% %	ASTM D 1299 ASTM D 1299	0,4-0,6 0,4-0,6
Dirección de flujo transversal <i>Cross flow direction</i>	% %	ASTM D 1299 ASTM D 1299	0,6-0,8 0,6-0,8

Propiedades físicas <i>Physicals properties</i>	Unidad <i>Unit</i>	Método para el test <i>Method test</i>	Valores <i>Value</i>
Absorción de agua <i>Water absorption</i> 24 horas, 23°C 24 hs, 23°C	%	ASTM D 570	0,06

Resistencia química del PBT
Chemical resistance of PBT

Ácidos <i>Acids</i>	°C	% días inmersión <i>% Immulsion days</i>	% Fuerza de retención <i>% Strenght of ritention</i>
10% Clorhídrico <i>10% Hydrochloric</i>	23	30	89
	23	90	85
	23	180	82
10% Sulfúrico <i>10% Sulfuric</i>	23	30	97
	23	90	94
	23	180	90
36% Sulfúrico (batería) <i>36% Sulfuric (battery)</i>	23	30	89
	23	30	97
	23	180	96
	66	30	84
10% Acético <i>10% Acetic</i>	23	30	89
	23	180	88

Bases <i>Bases</i>	°C	% días inmersión <i>% Immulsion days</i>	% Fuerza de retención <i>% Strenght of ritention</i>
5% Hidróxido de potasio <i>5% Potassium Hydroxide</i>	23	30	83
	23	90	10
10% Hidróxido de sodio <i>10% Sodium Hydroxide</i>	23	30	2
	23	180	-
10% Hidróxido de Amonio <i>10% Ammonium Hydroxide</i>	23	30	90
	23	90	87
	23	180	58

Solventes orgánicos <i>Organic Solvents</i>	°C	% días inmersión <i>% Immulsion days</i>	% Fuerza de retención <i>% Strenght of ritention</i>
Alcohol etílico <i>Ethyl Alcohol</i>	23	30	99
	23	180	94
Alcohol metílico <i>Methyl Alcohol</i>	23	30	91
	23	180	76
Alcohol isopropílico <i>Isopropyl-Alcohol</i>	23	30	100
	23	180	100
Alcohol isopropílico y agua (50:50) <i>Isopropyl-Alcohol & Water (50:50)</i>	23	30	93
	23	180	96
Aguarrás <i>Turpentine</i>	23	180	92
	23	30	66
Acetona <i>Acetonz</i>	23	180	63
	23	30	90



Tabla - Diámetros agujero del rodamiento
Table - Hole bearing diameters

Dimensiones Dimensions	Tipo soporte Support type	Rodamiento Bearing	Carga axial dinámica.[kN] Axial dynamic load (kN)	Carga radial dinámica.(kN) Radial dynamil load (kN)
Ø 6	a presión fixed	FK 6	706 DFA	-
		EK 6		
	de apoyo supported	EF 6	606 ZZ	-
		EF 8		
Ø 8	a presión fixed	FK 8	708 DFA	-
		EK 8		
	de apoyo supported	FF 10	608 ZZ	-
		BF 10		
Ø 10	a presión fixed	FK 10	7000 DFA	6,7
		BK 10		
	de apoyo supported	FF 12	6000 ZZ	-
		BF 12		
Ø 12	a presión fixed	FK 12	7001 DFA	7,25
		BK 12		
	de apoyo supported	-	-	-
		-	-	-
Ø 15	a presión fixed	FK 15	7003 DFA	7,75
		BK 15		
	de apoyo supported	FF 15	6002 ZZ	-
		BF 15		
Ø 17	a presión fixed	BK 17	7206 DFA	14
		BK 17		
	de apoyo supported	BF 17	6203 ZZ	-
		BF 17		
Ø 20	a presión fixed	FK 20	7204 DFA	18,3
		BK 20		
	de apoyo supported	FF 20	6204 ZZ	-
		BF 20		
Ø 25	a presión fixed	FK 25	7205 DFA	20,6
		BK 25		
	de apoyo supported	FF 25	6205 ZZ	-
		BF 25		
Ø 30	a presión fixed	FK 30	7206 DFA	28,6
		BK 30		
	de apoyo supported	FF 30	6206 ZZ	-
		BF 30		
Ø 35	a presión fixed	BK 35	7207 DFA	-
		BK 35		
	de apoyo supported	BF 35	6207 ZZ	-
		BF 35		
Ø 40	a presión fixed	BK 40	7208 DFA	45
		BK 40		
	de apoyo supported	BF 40	6208 ZZ	-
		BF 40		

NOTA:
Los soportes a presión EK montan los mismos rodamientos de los soportes FK de la misma dimensión.
Los soportes de apoyo EF montan los mismos rodamientos de los soportes de apoyo FF de la misma dimensión.

NOTE:
In the fixed supports EK there are the same bearings of the same size of fixed supports FK.
In the floated supports EF there are the same bearings of the same size of floated supports FF.

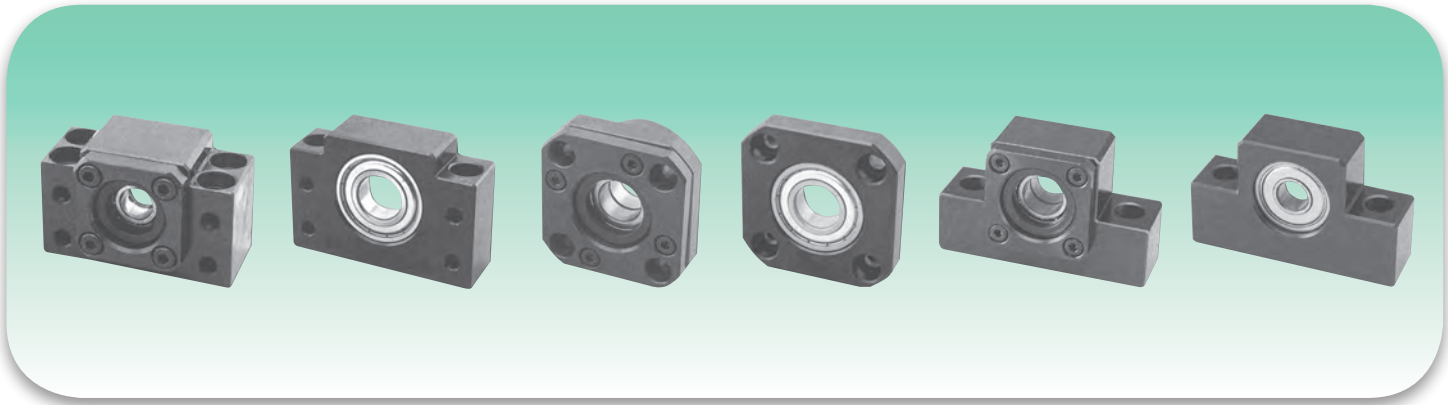
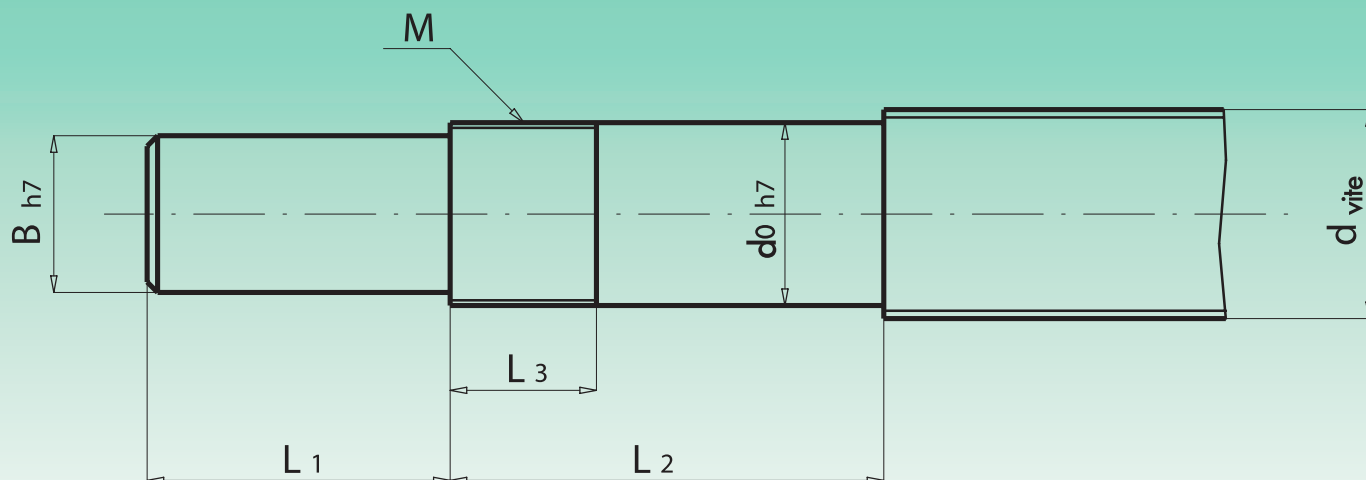

Para soportes tipo de montaje a presión FK, BK y EK.
For fixed-side support unit types FK, BK and EK.

Ejes recomendados - Recommended shaft and shape

Tipo Type	Dimensiones - Dimensions						
	d ₀	d _{tornillo}	B	L ₁	L ₂	M	L ₃
	mm						
FK 5	5	6	4	6	20	M 5x0.75	7
FK 6	6	8	4	8	24	M 6x0.75	8
FK 8	8	10	6	10	32	M 8x1	10
FK 10	10	12/14	8	15	39	M 10x1	12
FK 12	12	14/16	10	15	39	M 12x1	12
FK 15	15	20	12	20	41	M 15x1	12
FK 20	20	25/32	17	27	59	M 20x1	14
FK 25	25	32	20	36	68	M 25x1.5	18
FK 30	30	40	25	42	72	M 30x1.5	24
BK 10	10	12/14	8	15	39	M 10x1	12
BK 12	12	14/16	10	15	39	M 12x1	12
BK 15	15	20	12	20	41	M 15x1	12
BK 17	17	20/25	15	27	53	M 17x1	14
BK 20	20	25/32	17	27	53	M 20x1	14
BK 25	25	32	20	36	65	M 25x1.5	18
BK 30	30	40	25	42	72	M 30x1.5	24
BK 35	35	40	30	58	83	M 35x1.5	28
BK 40	40	50	35	70	98	M 40x1.5	35
EK 5	5	6	4	6	20	M 5x0.75	7
EK 6	6	8	4	8	24	M 6x0.75	8
EK 8	8	10	6	10	32	M 8x1	10
EK 10	10	12/14	8	15	39	M 10x1	12
EK 12	12	14/16	10	15	39	M 12x1	12
EK 15	15	20	12	20	41	M 15x1	12
EK 20	20	25/32	17	27	59	M 20x1	14

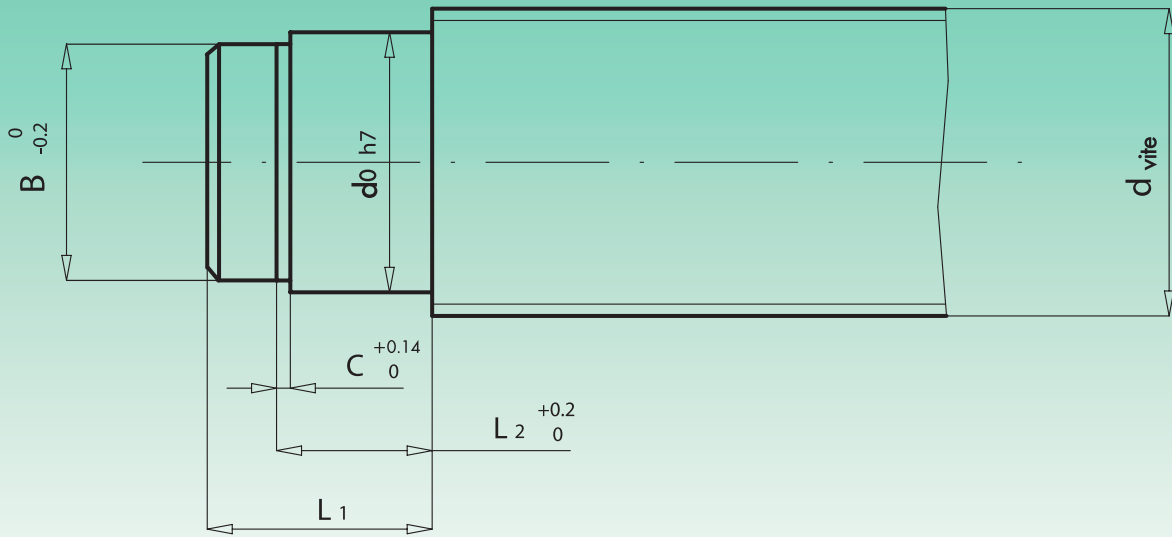

Para soportes tipo de apoyo FF, BF y EF.
For floated-side support unit types FF, BF and EF.

Ejes recomendados - Recommended shaft and shape

Tipo Type	Dimensiones - Dimensions					
	d_0	d_{tornillo}	B	C	L_1	L_2
mm						
FF 10	8	10/12	7,6	0,9	11	7,9
FF 12	10	16	9,6	1,15	12	9,15
FF 15	15	20	14,3	1,15	12	10,15
FF 20	20	25/32	19	1,35	18	15,35
FF 25	25	32	23,9	1,35	20	16,35
FF 30	30	40	28,6	1,75	20	17,75
BF 10	8	10/12	7,6	0,9	11	7,9
BF 12	10	16	9,6	1,15	12	9,15
BF 15	15	20	14,3	1,15	12	10,15
BF 17	17	20/25	16,2	1,15	16	13,15
BF 20	20	25/32	19	1,35	16	13,35
BF 25	25	32	23,9	1,35	20	16,35
BF 30	30	40	28,6	1,75	20	17,75
BF 35	35	40	33	1,75	25	19,75
BF 40	40	50	38	1,75	25	19,75
EF 6	6	8	5,6	0,8	9	7,0
EF 8	6	8	5,6	0,9	10	7,0
EF 10	8	10/12	7,6	0,9	11	7,9
EF 12	10	16	9,6	1,15	12	9,15
EF 15	15	20	14,3	1,15	12	10,15
EF 20	20	25/32	19	1.35	18	15,35

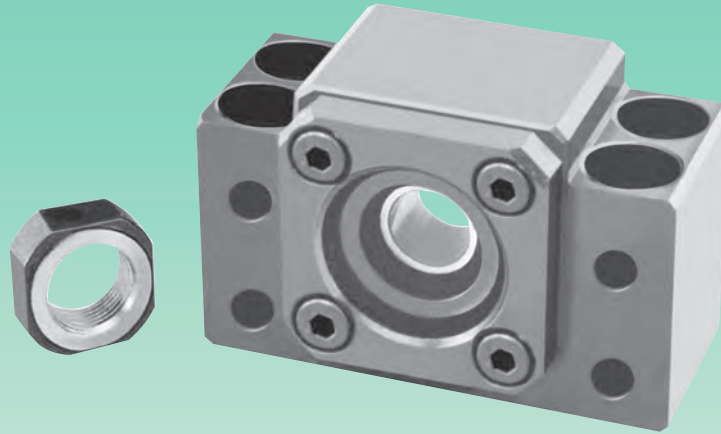
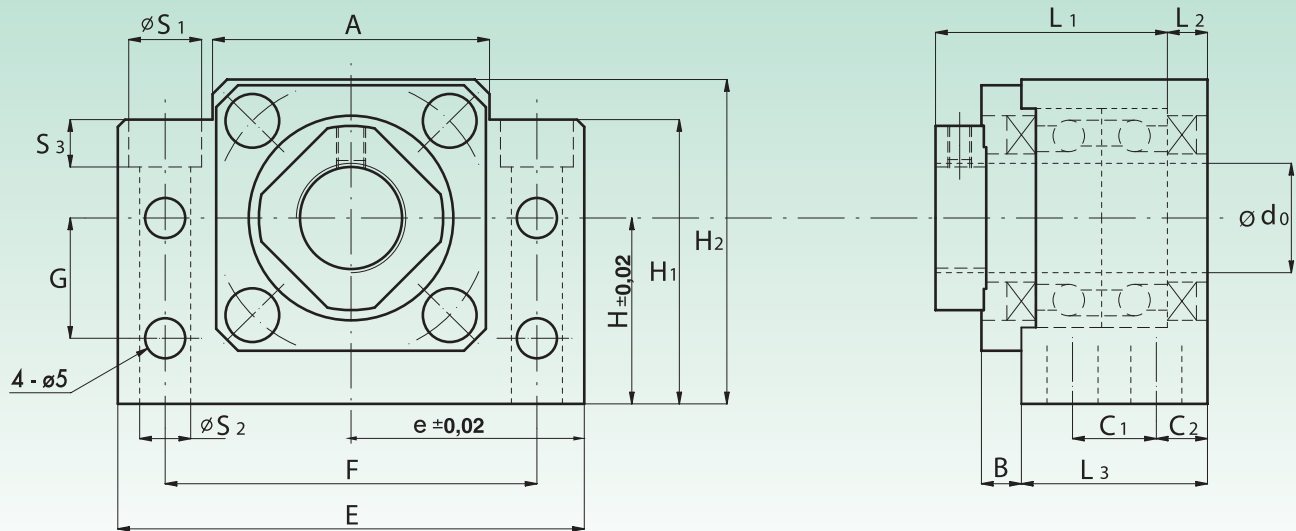
Soportes tipo de montaje a presión BK, FK y EK
Fixed-side support unit types BK, FK and EK

Tuerca incluida
Lock nut included

Tipo Type	Dimensiones - Dimensions																			
	d_0	L_1	L_2	L_3	$H \pm 0,02$	H_1	H_2	A	B	C_1	C_2	E	$e \pm 0,02$	F	G	s	S_1	S_2	S_3	
mm																				
BK 10	10	31	7	25	22	32,5	39	34	6	13	6	60	30	46	15	5,5	11	6,6	5	
BK 12	12	31	7	25	25	35	43	35	6	13	6	60	30	46	18	5,5	11	6,6	6,5	
BK 15	15	33	7	27	28	38	48	40	6	15	6	70	35	54	18	5,5	11	6,6	6,5	
BK 17	17	43	9	35	39	55	64	50	8	19	8	86	43	68	28	6,6	14	9	8,5	
BK 20	20	43	9	35	34	50	60	52	8	19	8	88	44	70	22	6,6	14	9	8,5	
BK 25	25	52	10	42	48	70	80	64	12	22	10	106	53	85	33	9	17,5	11	11	
BK 30	30	55	11	45	51	78	89	76	14	23	11	128	64	102	33	11	20	14	13	
BK 35	35	63	12	50	52	79	96	88	14	26	12	140	70	114	35	11	20	14	13	
BK 40	40	71	16	61	60	90	110	100	18	33	14	160	80	130	37	14	26	18	17,5	

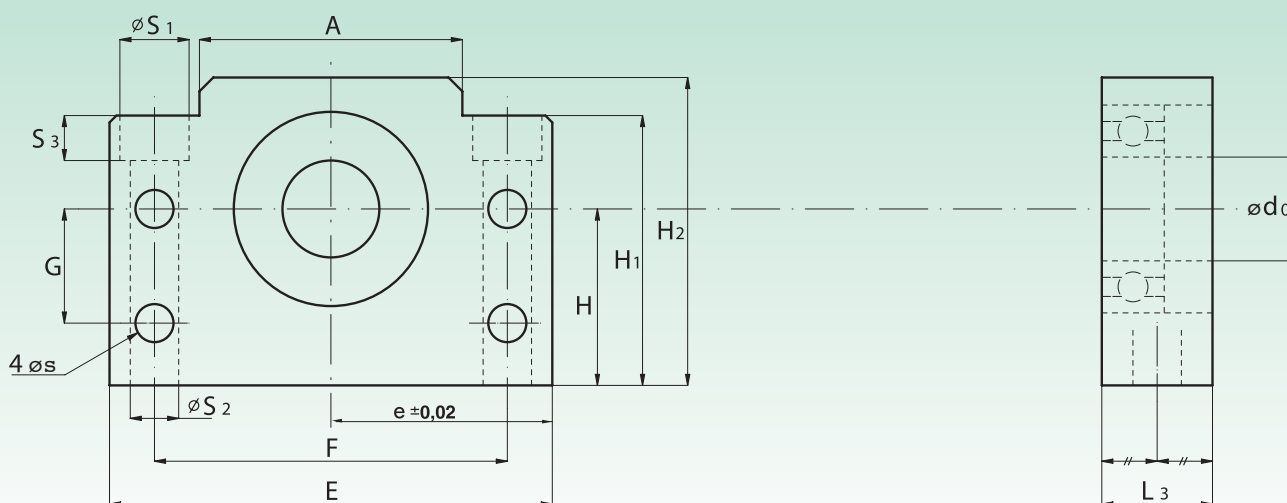
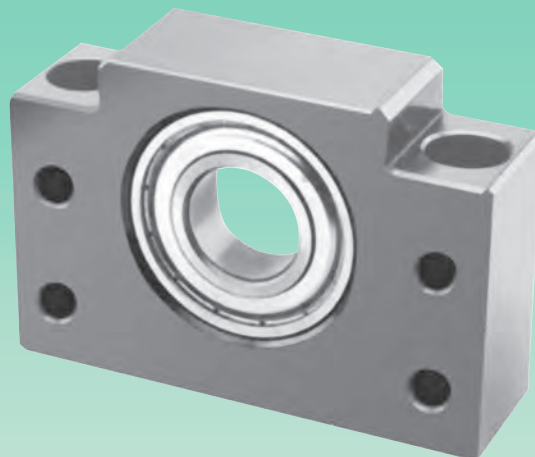
Soportes tipo de apoyo BF, FF y EF
Floated-side support unit types BF, FF and EF

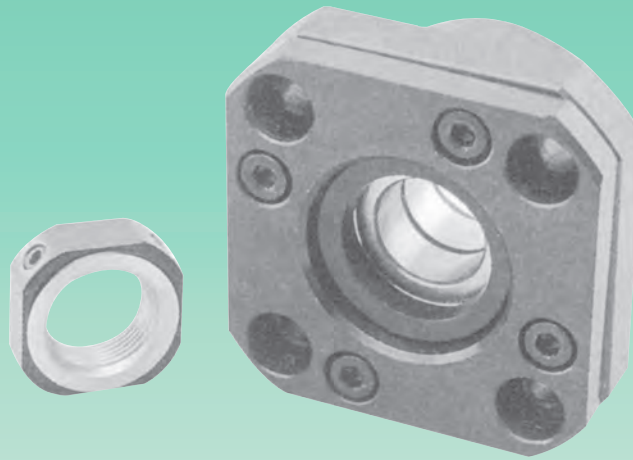
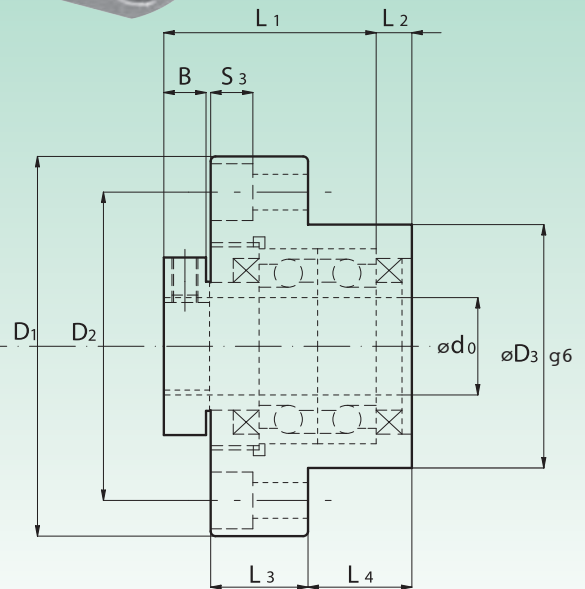
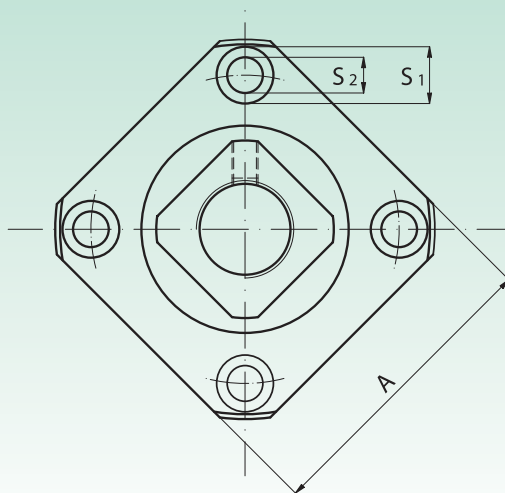

Tipo Type	Dimensiones - Dimensions													
	d ₀	L ₃	H ^{±0,02}	H ₁	H ₂	A	E	e ^{±0,02}	F	G	s	S ₁	S ₂	S ₃
mm														
BF 10	8	20	22	32,5	39	34	60	30	46	15	5,5	11	6,6	5
BF 12	10	20	25	35	43	35	60	30	46	18	5,5	11	6,6	6,5
BF 15	15	20	28	38	48	40	70	35	54	18	5,5	11	6,6	6,5
BF 17	17	23	39	55	64	50	86	43	68	28	6,6	14	9	8,5
BF 20	20	26	34	50	60	52	88	44	70	22	6,6	14	9	8,5
BF 25	25	30	48	70	80	64	106	53	85	33	9	17,5	11	11
BF 30	30	32	51	78	89	76	128	64	102	33	11	20	14	13
BF 35	35	32	52	79	96	88	140	70	114	35	11	20	14	13
BF 40	40	37	60	90	110	100	160	80	130	37	14	26	18	17,5

FK
Soportes tipo de montaje a presión FK, BK y EK
Fixed-side support unit types FK, BK and EK

Tuerca incluida
Lock nut included

Tipo Type	Dimensiones - Dimensions												
	d ₀	D ₁	D ₂	D ₃	L ₁	L ₂	L ₃	L ₄	A	B	S ₁	S ₂	S ₃
mm													
FK 5	5	34	26	20	18,5	3,5	6	10,5	26	5	6,5	3,4	4
FK 6	6	36	28	22	22	3,5	7	13	28	5	6,5	3,4	4
FK 8	8	43	35	26	26	4	9	14	35	6,5	6,5	3,4	4
FK 10	10	52	42	34	29	5	11	17	42	8	8	4,5	5
FK 12	12	54	44	36	29,5	5	11	17	44	8	8	4,5	5
FK 15	15	63	50	40	33	6	15	17	52	8	9,5	5,5	6
FK 20	20	85	70	57	48	10	22	30	68	10	11	6,6	10
FK 25	25	98	80	63	57	10	27	30	79	10	14	9	11
FK 30	30	117	95	75	60	11	30	32	93	12	17,5	11	13

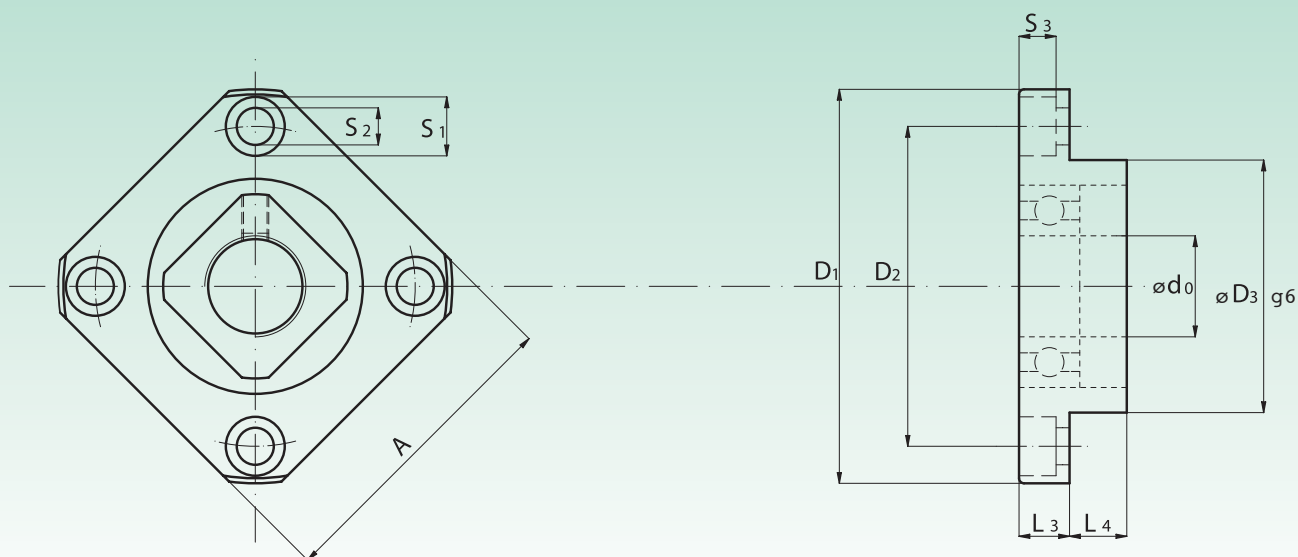
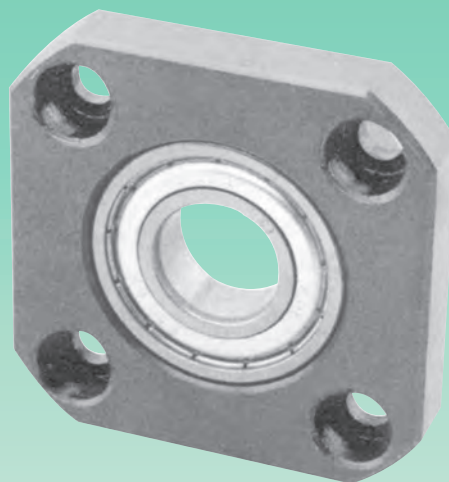
Soportes tipo de apoyo FF, BF y EF
Floated-side support unit types FF, BF and EF

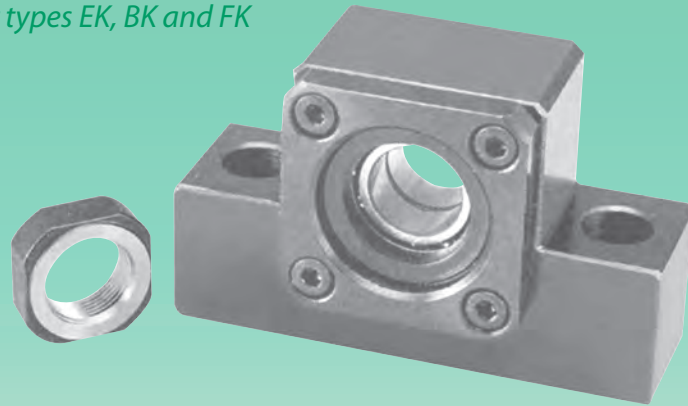
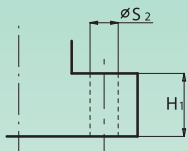

Tipo Type	Dimensiones - Dimensions									
	d_0	D_1	D_2	D_3	L_3	L_4	A	S_1	S_2	S_3
	mm									
FF 10	8	43	35	28	7	5	35	6,5	3,4	4
FF 12	10	52	42	34	7	8	42	8	4,5	4
FF 15	15	63	50	40	9	8	52	9,5	5,5	6
FF 20	20	85	70	57	11	9	68	11	6,6	6,5
FF 25	25	98	80	63	14	10	79	14	9	9
FF 30	30	117	95	75	18	17	93	17,5	11	11

Soportes tipo de montaje a presión EK, BK y FK
Fixed-side support unit types EK, BK and FK

Tuerca incluida
Lock nut included

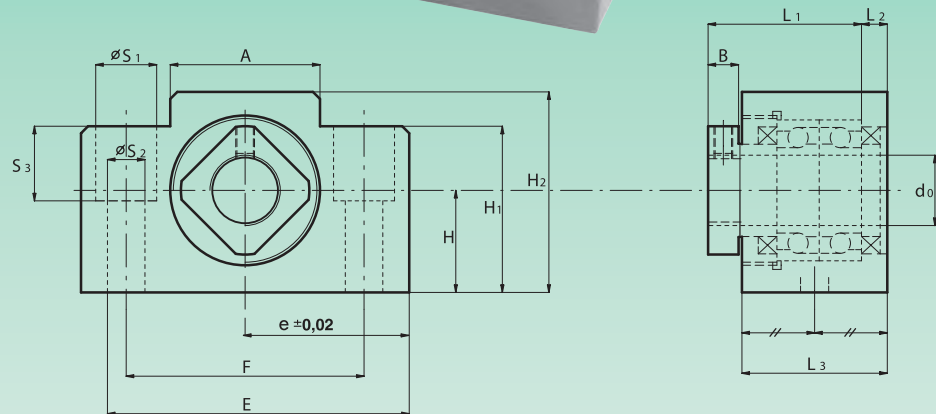
EK 5

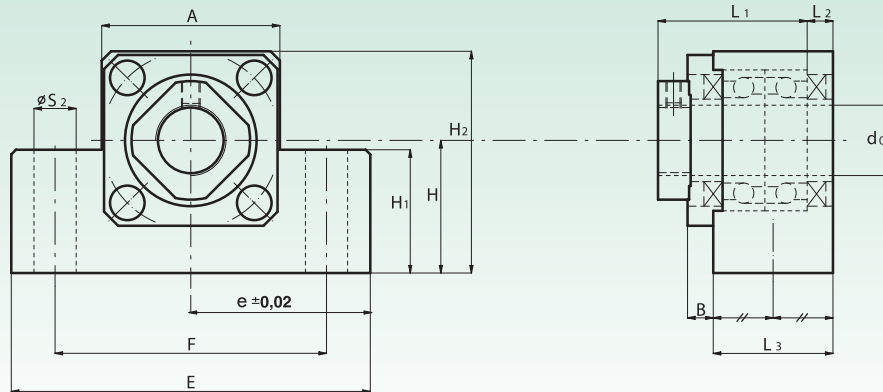

EK 6-8



EK 10 - 20

Tipo Type	Dimensiones - Dimensions														
	d_0	L_1	L_2	L_3	$H^{\pm 0,02}$	H_1	H_2	A	B	E	$e^{\pm 0,02}$	F	S_1	S_2	S_3
mm															
EK 5	5	18,5	3,5	16,5	11	8	21	20	5	36	18	28	-	4,5	-
EK 6	6	22	3,5	20	13	20	25	18	5	42	21	30	9,5	5,5	11
EK 8	8	26	4	23	17	26	32	25	6,5	52	26	38	11	6,6	12
EK 10	10	29	7	24	25	24	43	36	6	70	35	52	-	9	-
EK 12	12	29,5	7	24	25	24	43	36	6	70	35	52	-	9	-
EK 15	15	33	7	25	30	25	49	41	6	80	40	60	-	11	-
EK 20	20	48	10	42	30	25	58	56	10	95	47,5	75	-	11	-

Soportes tipo de apoyo EF, BF y FF

Floated-side support unit types EF, BF and FF

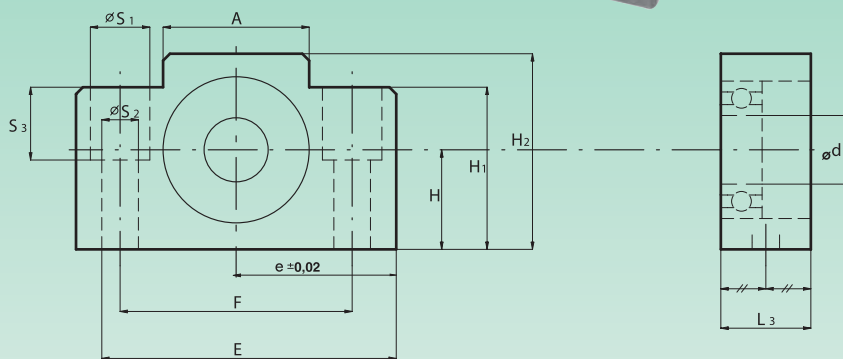
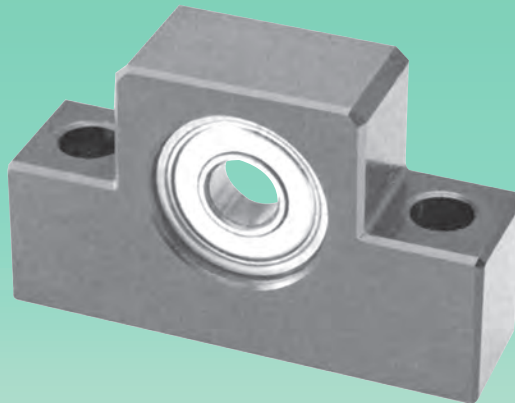

EF 6-8

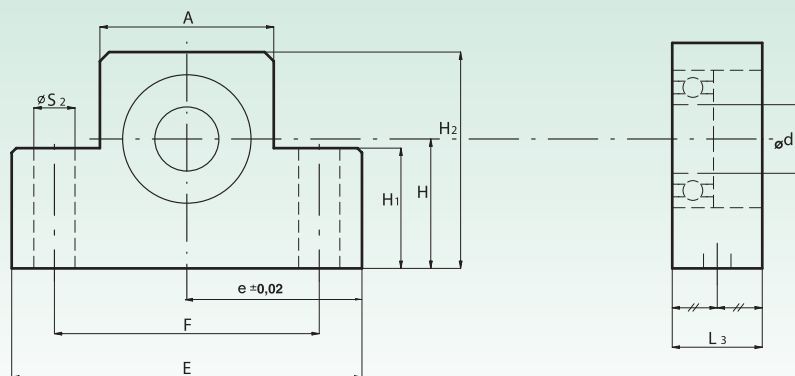

EF 10-20

Tipo Type	Dimensiones - Dimensions											
	d_0	L_3	$H \pm 0,02$	H_1	H_2	A	E	$e \pm 0,02$	F	S_1	S_2	S_3
mm												
EF 6	6	12	13	20	25	18	42	21	30	9,5	5,5	11
EF 8	6	14	17	26	32	25	52	26	38	11	6,6	12
EF 10	8	20	25	24	43	36	70	35	52	-	9	-
EF 12	10	20	25	24	43	36	70	35	52	-	9	-
EF 15	15	20	30	25	49	41	80	40	60	-	9	-
EF 20	20	26	30	25	58	56	95	47,5	75	-	11	-

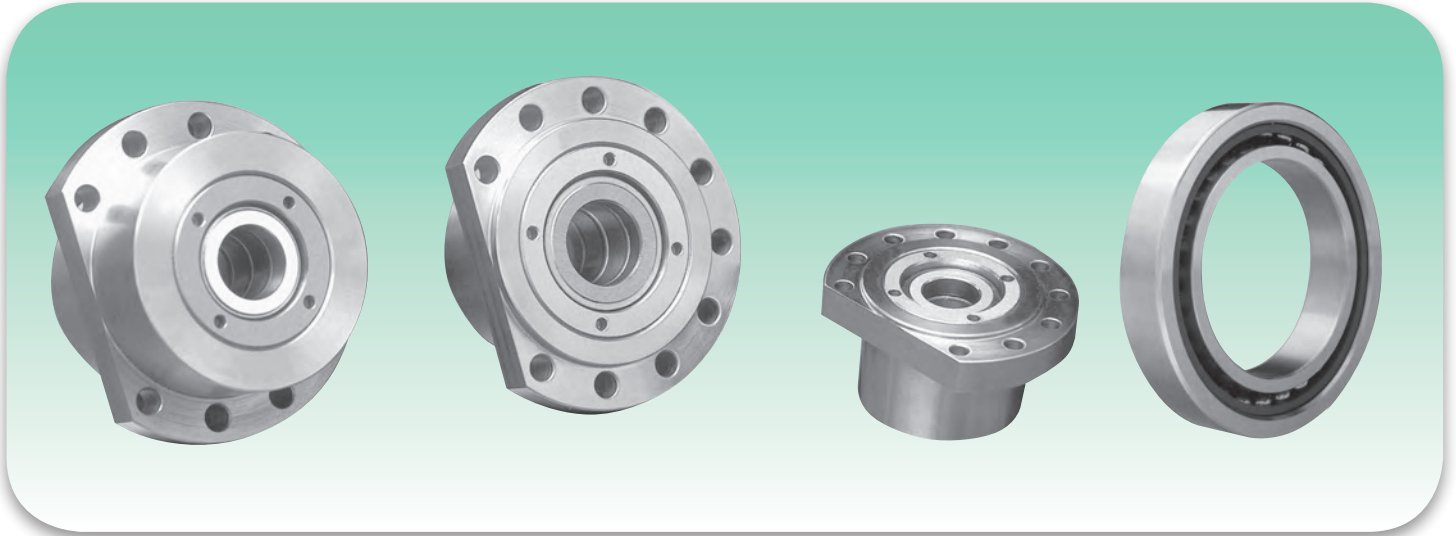
Soportes con rodamientos de precisión axial de contacto angular
Supports with precision axial angular contact bearings

CARACTERÍSTICAS TÉCNICAS
TECHNICAL CHARACTERISTICS

- **Material**
Soporte: Acero C40 rectificado.
- **Rodamientos:** ISB axiales de contacto angular de la serie dimensional ISO 02 (código equivalente: FAG 76020) ángulo de contacto 60°.
- **Clase de precisión:** Tolerancias reducidas en la clase de precisión ISO P4 correspondiente a la clase ISO P4S.
- **Precarga:** Los rodamientos se fabrican con diseño universal. Los valores de precarga se indican en la siguiente tabla y corresponden a valores de precarga elevados. Pueden ser suministradas grupos de dos y de cuatro con valores de precarga a petición.
- **Material**
Bearing unit: C40 rectified steel.
- **Bearings:** Angular contact thrust ball bearings ISB of dimensional series ISO 02 (equivalent code: FAG 76020). Contact angle 60°.
- **Precision class:** Reduced tolerances in ISO P4 precision class, corresponding to ISO P4S.
- **Pre-load:** Bearings are produced in universal execution. Preload values are indicated in the following table and correspond to high preload values. Couples and quaternary groups of pre-load values can be provided by specific request.

Soportes con rodamientos de precisión axiales de contacto angular

Supports with precision axial angular contact bearings

- Fuerza de apriete:** En caso de una fuerza de apriete excesiva, los aros del rodamiento sufren una deformación elástica que provoca un aumento de la fuerza de precarga y una disminución de la vida útil. El valor de la fuerza de apriete se podrá calcular tomando como referencia la tabla que sigue a continuación.
- Tolerancias:** Las tolerancias de mecanizado y las dimensiones de montaje se indican en las siguientes tablas:

- Clamping force:** In case of very strong clamping force, bearings rings are affected by an elastic deformation that causes an increase of the pre-load force together with a shortening of the duration. The value of the clamping force can be calculated by means of the table below.
- Tolerances:** The following table reports the working tolerances and the mounting dimensions:

FUERZAS DE APRIETE F ₂ ACONSEJADAS - RECOMMENDED F ₂ CLAMPING FORCES							
Disposición rodamiento <i>Position of the bearing</i>							
Fz [N]	3 - Fv		4 - Fv		6 - Fv		
Rosca Thread	M5	M6	M8	M10	M12	M14	M16
Factor F Factor F	0,98	1,18	1,55	1,9	2,35	2,7	30,5

La fuerza de apriete F₂ se alcanza cuando los tornillos de la tapa se aprietan con un par M.

$$M = Fz/f[Nmm]$$

N = Número de tornillos de la tapa

f. = Factor de corrección

Clamping force F₂ is achieved when the cover's ball screws are clamped with the M couple.

$$M = Fz/f (Nmm)$$

N = number of cover's ball screws

f. = Correction factor

TOLERANCIAS DE MECANIZADO DE LOS EJES Y DE LAS PARTES ADYACENTES

WORKING TOLERANCES OF SHAFT AND ADJACENT PARTS

VALORES INDICATIVOS PARA EL MECANIZADO DE LOS EJES							
VALUES FOR PROCESSING SHAFTS							
Dimensión nominal del eje (d) <i>Shaft's nominal dimension (d)</i>	Dimensiones - Dimensions						
	mm						
	Más de / Over	10	18	30	50		
hasta / up to	10	18	30	50	80		
RODAMIENTOS AXIALES DE BOLAS CON CONTACTO ANGULAR DE SIMPLE EFECTO							
SIMPLE EFFECT ANGULAR CONTACT AXIAL BALL BEARINGS							
Diferencia (d) <i>(d) deviation</i>		-9	-11	-13	-15		
Precisión de forma cilíndrica <i>Cylindrical form precision</i>	t1	2,5	2,5	3	4		
Precisión axial de rotación <i>Axial rotation precision</i>	t3	2,5	2,5	3	4		
Valor medio de rugosidad <i>Roughness mean value</i>	Ra	0,4	0,4	0,4	0,4		

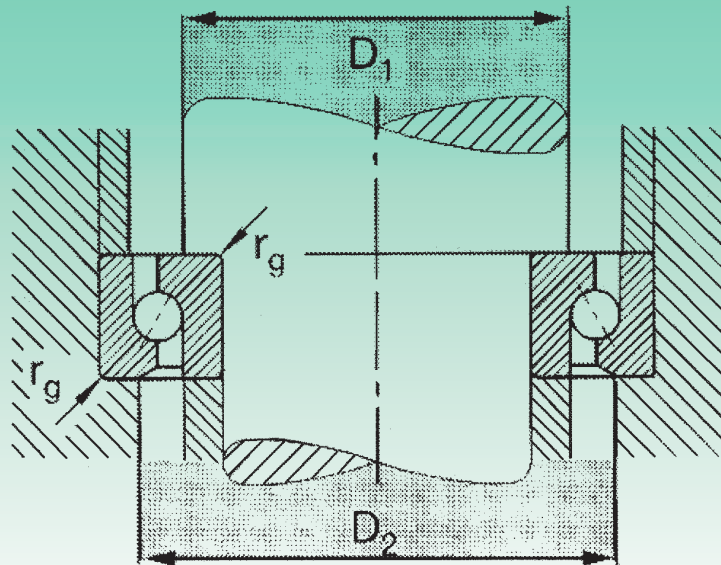
Soportes con rodamientos de precisión axial de contacto angular
Supports with precision axial angular contact bearings

DIMENSIONES DE MONTAJE PARA RODAMIENTOS AXIALES DE BOLAS CON CONTACTO ANGULAR
MOUNTING DIMENSIONS FOR ANGULAR CONTACT AXIAL BALL BEARINGS

Eje Shaft	Rodamiento tipo ISB 204714 AC (equivalente Fag 76020) 204714 AC ISB type bearing (Fag 76020 equivalent)		
Agujero Bore	D1	D2	rg
mm	min	min	máx
12	17	27	0,6
15	20,5	30	0,6
17	23	34,5	0,6
20	27,5	39,5	0,6
25	32	45	1
30	39,5	52,5	1
35	46,5	60,5	1
40	53,5	69,5	1
45	57	73	1
50	63	79	1

• **Obturaciones:** Los segmentos de láminas de 3 anillos de expansión simples, tipo FK3 AS, fabricados con acero para resortes C75, crean una clásica obturación de laberinto.

• **Lubricación:** Grasas al jabón de litio, con aditivos EP como por ejemplo la grasa ARCANOL L 135V, consistencia 2, °C – 40 + 150. Los soportes se suministran ya lubricados, con la cantidad indicada en la siguiente tabla.

• **Seals:** Spathic segments fey with three expander rings, FK3 AS type, made of steel for stainless steel C75 springs, create a typical labyrinth seal.

• **Lubrication:** Lithium soap greases with EP additives like ARCANOL L 135V grease, consistency 2, °C-40 + 150. Bearing units are supplied when already lubrified in the quantity indicated in the next table.

Soportes con rodamientos de precisión axiales de contacto angular
Supports with precision axial angular contact bearings

Cantidades de grasa para rodamientos axiales de bolas con contacto angular, de una hilera
Quantities of grease for angular contact axial ball bearings, single row.

Sigla Fag <i>Type Fag</i>	7602020TVP	7602025TVP	7602030TVP	7602035TVP
grasa g. / grease g.	1,42	1,95	2,65	3,7
Sigla Fag <i>Type Fag</i>	7602040TVP	7602045TVP	7602050TVP	
grasa g. / grease g.	4,45	5,35	6,5	

- **Accesorios:** Tuercas de precisión rectificadas con pasadores de fijación, serie ZM.

- **Tools:** Precision ground lock-nuts with dowel fixing, ZM series.

DISEÑO UNIDAD DE CARTUCHO DE BRIDA
UNITY EXECUTIONS - FLANGED CARTRIDGE

Tipo <i>Type</i>	Descripción <i>Specification</i>
ISB FD	DE BRIDA CON 2 RODAMIENTOS A 'O' <i>FLANGED WITH 2 'O' BEARINGS</i>
ISB FQ	DE BRIDA CON 4 RODAMIENTOS A 'O' <i>FLANGED WITH 4 'O' BEARINGS</i>
ISB FDX	DE BRIDA CON 2 RODAMIENTOS A 'X' <i>FLANGED WITH 2 'X' BEARINGS</i>
ISB FQX	DE BRIDA CON 4 RODAMIENTOS A 'X' <i>FLANGED WITH 4 'X' BEARINGS</i>

TABLA DE EQUIVALENCIA
EQUIVALENT TABLE

Tipo ISB <i>ISB Type</i>	SNFA	FAFNIR	RHP
ISB FD	BSDU DD	BSBU D	BSCU D
ISB FQ	BSQU TDT	BSBU Q	BSCU Q
ISB FDX	BSDU FF	-	-
ISB FQX	BSQU TFT	-	-

CÓDIGO DE IDENTIFICACIÓN
SPECIFICATION CODE

ISB	F	D	X	030	precarga de N <i>pre-load from N</i>	
MARCA <i>BRAND</i>	DISEÑO CON BRIDA <i>FLANGED EXECUTION</i>	D=2 RODAMIENTOS Q=4 RODAMIENTOS D=2 BEARINGS Q=4 BEARINGS		AGUJERO RODAMIENTO <i>BEARING BORE</i>	Ningún número: <i>Without number:</i>	
			Ningún <i>No</i>	020 = 20 MM	diseño	<i>execution</i>
			código <i>code</i>	025 = 25 MM	precarga.	<i>pre-load.</i>
			diseño a <i>of execution</i>	030 = 30 MM	universal	<i>universal</i>
			'O'	035 = 35 MM	Con número:	<i>With number:</i>
			X para <i>X for</i>	040 = 40 MM	precarga	<i>pre-load</i>
			diseño a <i>execution in</i>	045 = 45 MM	Especial X	<i>Special X</i>
			'X'	050 = 50 MM	360=360 de N	<i>360=360 from N</i>

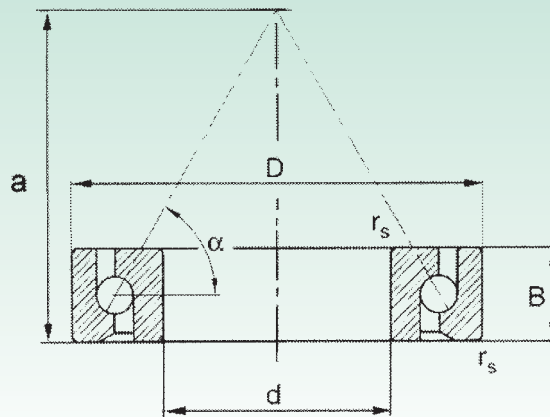

204714 AC

 Angulo de contacto $\alpha \approx 60^\circ$ - Contact Angle $\alpha \approx 60^\circ$

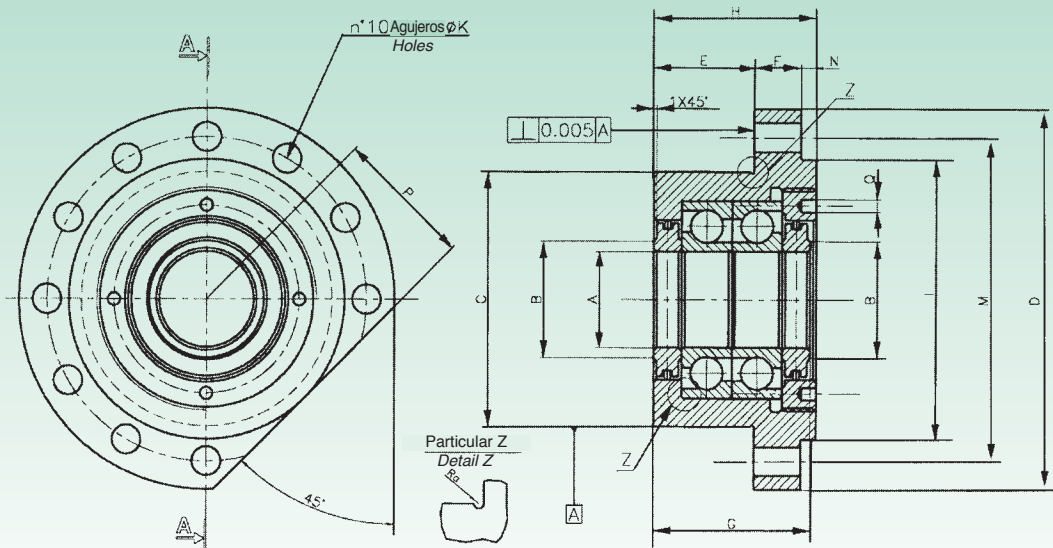
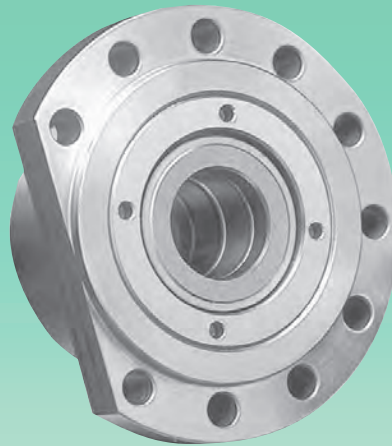
Rodamientos ISB Bearings	Equivalente FAG Equivalent	Dimensiones - Dimensions					Capacidad de carga Load ability		Carga axial Axial load max	Velocidad rotación obtenible Achievable rotation speed		Fuerza de precarga Pre-load force	Momento de fricción Friction point	Peso Weight
							din.	Estát.		Velocidad - Speed				
Tipo Type	Tipo Type	d	D	B	r _{smin}	a ≈	C	Co	din	Grasa Grease	Aceite Oil	Fv	Mr	Kg
		mm					KN				kN		Nmm	
174012AC	7602017TVP	17	40	12	0,6	31	16,6	20	8,5	6000	8000	1,7	30	0,075
204714AC	7602020TVP	20	47	14	1	6	19,3	25	10,6	5000	6700	2,3	50	0,130
255215AC	7602025TVP	25	52	15	1	41	22	30,5	13,2	4500	6000	2,5	65	0,160
306216AC	7602030TVP	30	62	16	1	48	26	39	17	3800	5000	2,9	85	0,240
357217AC	7602035TVP	35	72	17	1,1	55	30	50	21,2	3200	4300	3,3	115	0,345
408018AC	7602040TVP	40	80	18	1,1	62,5	37,5	64	28	2800	3800	4,3	170	0,445
458519AC	7602045TVP	45	85	19	1,1	66	38	68	28	2800	3600	4,5	190	0,505
509020AC	7602050TVP	50	90	20	1,1	71,5	39	75	31,5	2400	3400	4,9	230	0,575

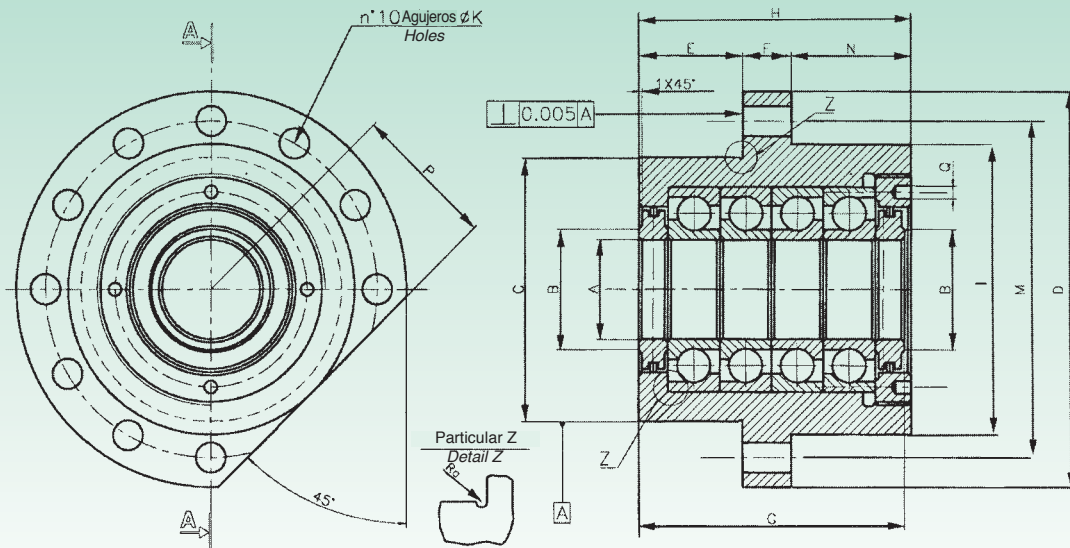

EJE Ø mm. SHAFT Ø mm.	Tipo Type	SOPORTES ISB TIPO FD PARA RODAMIENTOS - DIMENSIONES SIN TOLERANCIA : ± 0.13 mm. ISB UNITS TYPE FD, FOR BEARINGS - DIMENSIONS WITHOUT TOLERANCE: ± 0.13 mm.														
		A	B	C	D	E	F	G	H	I	K	M	N	P	Q	Rc
17	ISB FD 017 (17-40-12)	17 16.996	25	60 59.987	90	32	13	44.260 43.240	47	64	6,6	76	2	32	4,3	0,5
20	ISB FD 020 (20-47-14)	20 19.669	28	60 59.987	90	32	13	44.260 43.240	47	64	6,6	76	2	32	4,3	0,5
25	ISB FD 025 (25-52-12)	25 24.996	35	80 79.987	120	32	15	50.260 49.240	52	88	9,2	102	5	44	4,3	0,5
30	ISB FD 030 (30-62-12)	30 29.996	41	80 79.987	120	32	15	50.260 49.240	52	88	9,2	102	5	44	4,3	0,5
35	ISB FD 035 (35-72-17)	35 34.995	46	90 89.987	130	32	15	50.260 49.240	52	98	9,2	113	5	49	4,3	0,5
40	ISB FD 040 (40-80-18)	40 39.995	55	124 123.982	165	43,5	17	64.260 63.240	66	128	11,4	146	5,5	32	5,3	0,5
45	ISB FD 045 (45-85-19)	45 44.995	66	124 123.982	165	43,5	17	64.260 63.240	66	128	11,4	146	5,5	44	5,3	0,5
50	ISB FD 050 (50-90-20)	50 49.995	66	124 123.982	165	43,5	17	64.260 63.240	66	128	11,4	146	5,5	44	5,3	0,5



EJE \varnothing mm. SHAFT \varnothing mm.	Tipo Type	SOPORTES ISB TIPO FD PARA RODAMIENTOS - DIMENSIONES SIN TOLERANCIA : ± 0.13 mm. ISB UNITS TYPE FD, FOR BEARINGS - DIMENSIONS WITHOUT TOLERANCE: ± 0.13 mm.														
		A	B	C	D	E	F	G	H	I	K	M	N	P	Q	Rc
17	ISB FQ 017 (17-40-12)	17 16.996	25	60 59.987	90	32	13	74.260 72.740	77	64	6,6	76	32	32	4,3	0,5
20	ISB FQ 020 (20-47-14)	20 19.669	28	60 59.987	90	32	13	74.260 72.740	77	64	6,6	76	32	32	4,3	0,5
25	ISB FQ 025 (25-52-15)	25 24.996	35	80 79.987	120	32	15	80.260 78.240	82	88	9,2	102	35	44	4,3	0,5
30	ISB FQ 030 (30-62-16)	30 29.996	41	80 79.987	120	32	15	80.260 78.740	83	88	9,2	102	36	44	4,3	0,5
35	ISB FQ 035 (35-72-17)	35 34.995	46	90 89.987	130	32	15	84.260 82.740	86	98	9,2	113	39	49	4,3	0,5
40	ISB FQ 040 (40-80-18)	40 39.995	55	124 123.982	165	43,5	17	104.260 102.740	106	128	11,4	146	45,5	64	5,3	0,5
45	ISB FQ 045 (45-85-19)	45 44.995	66	124 123.982	165	43,5	17	104.260 102.740	106	128	11,4	146	45,5	64	5,3	0,5
50	ISB FQ 050 (50-90-20)	50 49.995	66	124 123.982	165	43,5	17	104.260 102.740	106	128	11,4	146	45,5	64	5,3	0,5



©Copyright ISB*

Está prohibida la reproducción, incluso parcial, del contenido de este Catálogo Técnico. No se acepta ningún tipo de responsabilidad en caso de errores u omisiones. Las medidas no son vinculantes. Marca registrada Italia-EU.

The reproduction, even partial, of the contained concerning this Technical Catalogue, is forbidden. Liability for possible errors and/or omissions are not accepted. Sizes are not binding.
™ Registered in Italy-EU.



SOPORTES AUTOALINEANTES
SELF-ALIGNING BEARING UNITS

1.07.12 ©Copyright **ISB**[®]



79991018



MISTO
Carta de fonti gestita
in maniera responsabile
FSC® C101645