

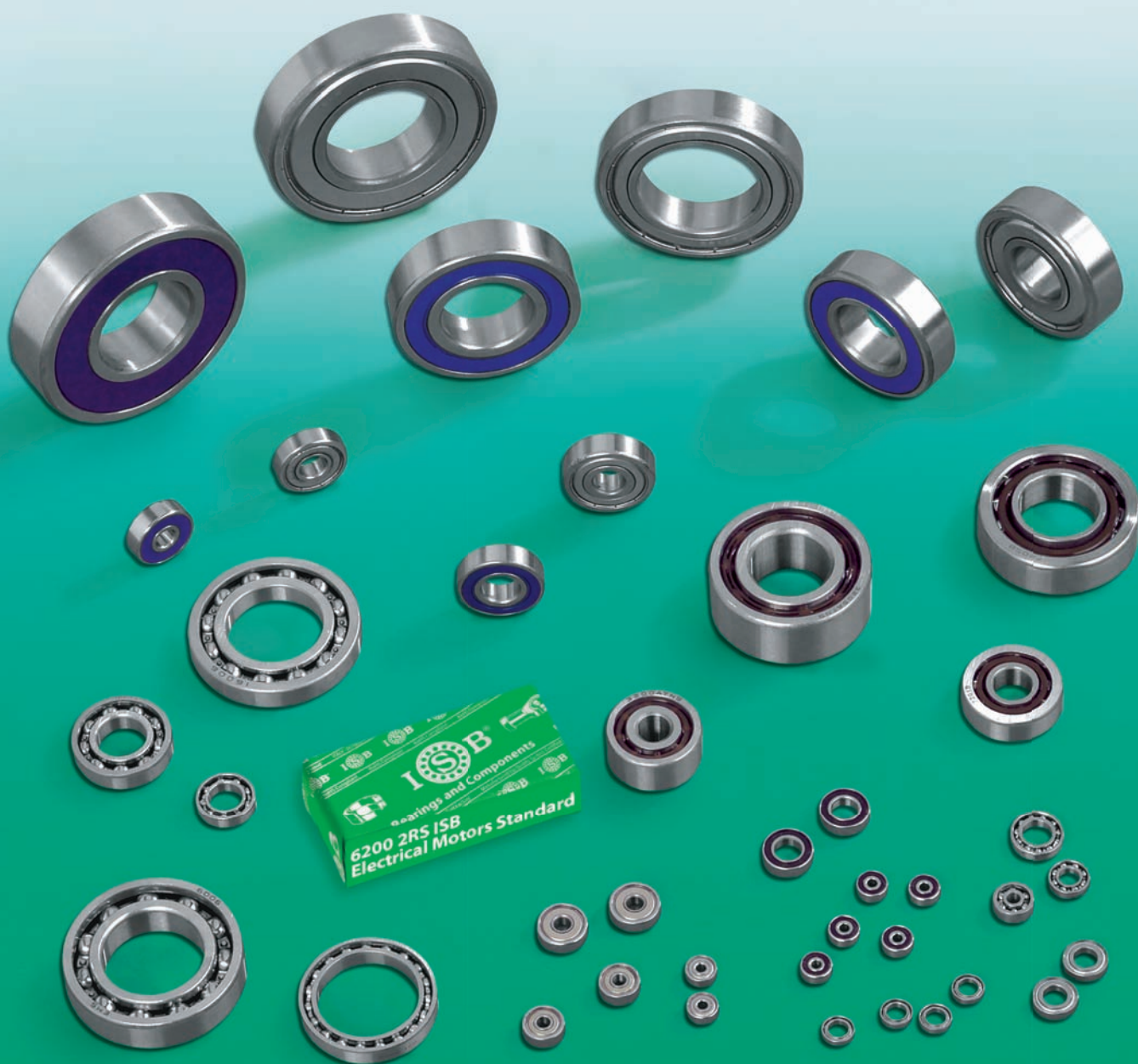

ELECTRICAL **M**OTORS **S**TANDARD

CUSCINETTI PER APPLICAZIONI "BASSA RUMOROSITÀ"
BEARINGS FOR "LOW NOISE" APPLICATIONS



CATALOGO TECNICO GENERALE
GENERAL TECHNICAL CATALOGUE



1.03.11

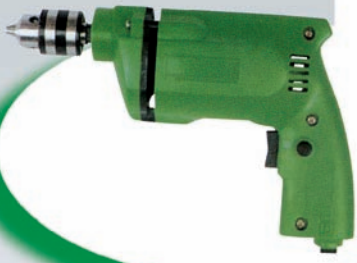

ELECTRICAL MOTORS STANDARD

CUSCINETTI PER APPLICAZIONI "BASSA RUMOROSITÀ"
BEARINGS FOR "LOW NOISE" APPLICATIONS

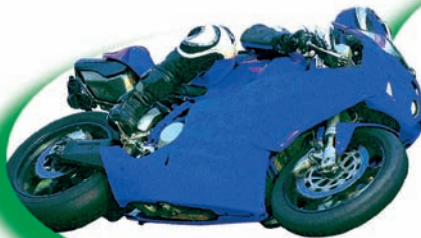

Politica ambientale

Il presente **Catalogo Tecnico ISB®** è stato realizzato con **materiale ecologico riciclato al 100%**.
Il processo produttivo della carta avviene attenendosi alle vigenti normative: **DS/EN ISO 14001 e ISO 9001:2000**.
Gli inchiostri utilizzati per la stampa, sono a base vegetale. Per cortesia, continuate nel Vostro impegno costante per la salvaguardia dell'ambiente

Environmental policy

*This **Technical Catalogue ISB®** has been produced with **100% ecological recycled paper**.
Manufacturing process follows the regulations in force: **DS/EN ISO 14001 and ISO 9001:2000**.
Inks used are vegetable based. Please continue your actions in order to protect the environment and recycle properly.*



ELECTRICAL **M**OTORS **S**TANDARD

CATALOGO TECNICO GENERALE
GENERAL TECHNICAL CATALOGUE

Distributore / Distributor

PAESI DOVE SIAMO PRESENTI

COUNTRIES WHERE WE ARE REPRESENTED

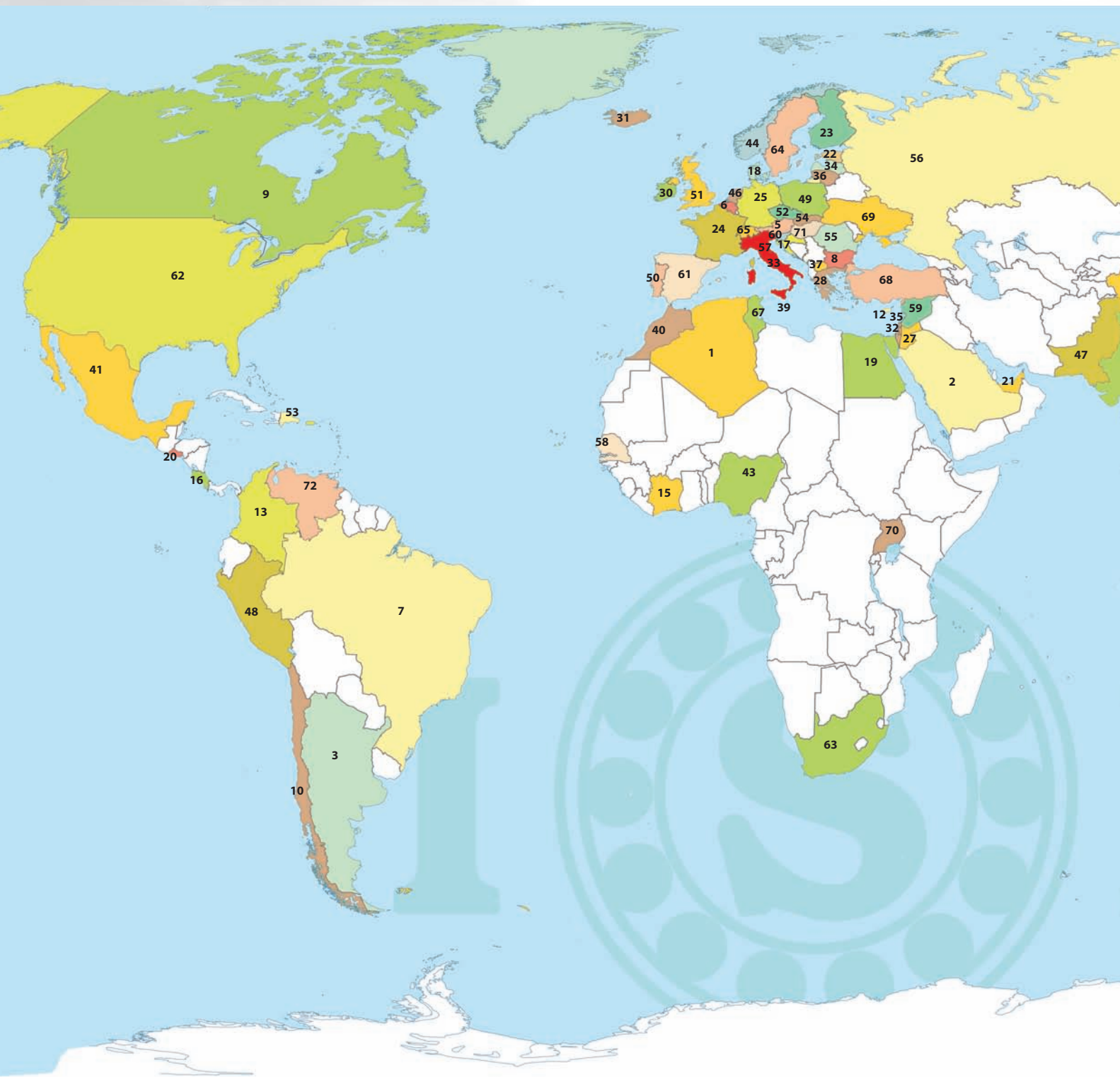

***ora legale (periodo da marzo ad ottobre in Italia)**

*summer time (from march to october in Italy)

ora solare (-1)

standard time (-1)

per le capitali con l'orario indicato in rosso non c'è ora legale

time is indicated in red for Capitals without summer time



	1 ALGERIA (Algeri - 11:00)	ALGERIA
	2 ARABIA SAUDITA (Riyadh - 13:00)	SAUDI ARABIA
	3 ARGENTINA (Buenos Aires - 07:00)	ARGENTINA
	4 AUSTRALIA (Canberra - 20:00)	AUSTRALIA
	5 AUSTRIA (Vienna - 12:00)	AUSTRIA
	6 BELGIO (Bruxelles - 12:00)	BELGIUM
	7 BRASILE (Brasilia - 07:00)	BRAZIL
	8 BULGARIA (Sofia - 13:00)	BULGARIA
	9 CANADA (Ottawa - 06:00)	CANADA
	10 CILE (Santiago - 06:00)	CHILE
	11 CINA (Pechino - 18:00)	CHINA
	12 CIPRO (Nicosia - 13:00)	CYPRUS
	13 COLOMBIA (Bogotà - 05:00)	COLOMBIA
	14 COREA DEL SUD (Seul - 19:00)	SOUTH KOREA
	15 COSTA D'AVORIO (Abidjan - 10:00)	IVORY COAST
	16 COSTA RICA (San José - 04:00)	COSTA RICA
	17 CROAZIA (Zagabria - 12:00)	CROATIA
	18 DANIMARCA (Copenaghen - 12:00)	DENMARK
	19 EGITTO (Cairo - 13:00)	EGYPT
	20 EL SALVADOR (San Salvador - 04:00)	EL SALVADOR
	21 EMIRATI ARABI UNITI (Abu Dhabi - 14:00)	UNITED ARAB EMIRATES
	22 ESTONIA (Tallinn - 13:00)	ESTONIA
	23 FINLANDIA (Helsinki - 13:00)	FINLAND
	24 FRANCIA (Parigi - 12:00)	FRANCE
	25 GERMANIA (Berlino - 12:00)	GERMANY
	26 GIAPPONE (Tokyo - 19:00)	JAPAN
	27 GIORDANIA (Amman - 13:00)	JORDAN
	28 GRECIA (Atene - 13:00)	GREECE
	29 INDIA (Nuova Delhi - 15:30)	INDIA
	30 IRLANDA (Dublino - 11:00)	IRELAND
	31 ISLANDA (Reykjavik - 10:00)	ICELAND
	32 ISRAELE (Gerusalemme - 13:00)	ISRAEL
	33 ITALIA (Roma - 12:00)*	ITALY
	34 LETTONIA (Riga - 13:00)	LATVIA
	35 LIBANO (Beirut - 13:00)	LEBANON
	36 LITUANIA (Vilnius - 13:00)	LITHUANIA
	37 MACEDONIA (Skopje - 12:00)	MACEDONIA
	38 MALAISIA (Kuala Lumpur - 18:00)	MALAYSIA
	39 MALTA (Valletta - 12:00)	MALTA
	40 MAROCCO (Rabat - 10:00)	MOROCCO
	41 MESSICO (Città del Messico - 06:00)	MEXICO
	42 NEPAL (Kathmandu - 15:45)	NEPAL
	43 NIGERIA (Abuja - 11:00)	NIGERIA
	44 NORVEGIA (Oslo - 12:00)	NORWAY
	45 NUOVA ZELANDA (Wellington - 22:00)	NEW ZEALAND
	46 OLANDA (Amsterdam - 12:00)	NETHERLANDS
	47 PAKISTAN (Islamabad - 16:00)	PAKISTAN
	48 PERÙ (Lima - 05:00)	PERU
	49 POLONIA (Varsavia - 12:00)	POLAND
	50 PORTOGALLO (Lisbona - 11:00)	PORTUGAL
	51 REGNO UNITO (Londra - 11:00)	UNITED KINGDOM
	52 REPUB. CECA (Praga - 12:00)	CZECH REPUBLIC
	53 REPUB. DOMINICANA (Santo Domingo - 06:00)	DOMINICAN REPUBLIC
	54 REPUB. SLOVACCA (Bratislava - 12:00)	SLOVAKIAN REPUBLIC
	55 ROMANIA (Bucarest - 13:00)	RUMANIA
	56 RUSSIA (Mosca - 14:00)	RUSSIA
	57 SAN MARINO (San Marino - 12:00)	SAN MARINO
	58 SENEGAL (Dakar - 10:00)	SENEGAL
	59 SIRIA (Damasco - 13:00)	SYRIA
	60 SLOVENIA (Lubiana - 12:00)	SLOVENIA
	61 SPAGNA (Madrid - 12:00)	SPAIN
	62 STATI UNITI D'AMERICA (Washington - 06:00)	UNITED STATES OF AMERICA
	63 SUD AFRICA (Pretoria - 12:00)	SOUTH AFRICA
	64 SVEZIA (Stoccolma - 12:00)	SWEDEN
	65 SVIZZERA (Berna - 12:00)	SWITZERLAND
	66 TAIWAN (Taipei - 18:00)	TAIWAN
	67 TUNISIA (Tunisi - 11:00)	TUNISIA
	68 TURCHIA (Ankara - 13:00)	TURKEY
	69 UCRAINA (Kiev - 13:00)	UKRAINE
	70 UGANDA (Kampala - 14:00)	REPUBLIC OF UGANDA
	71 UNGHERIA (Budapest - 12:00)	HUNGARY
	72 VENEZUELA (Caracas - 06:00)	VENEZUELA

Cuscinetti per applicazioni “bassa rumorosità”

Produzione

Tutti i prodotti **ISB®** sono costruiti esclusivamente da aziende con Sistema Qualità certificato secondo le norme **UNI EN ISO 9001:2000**.



Production

All products **ISB®** are manufactured exclusively by companies with **UNI EN ISO 9001:2000** certified Quality System.



Controllo qualità Asia

... un'ulteriore serie di controlli vengono eseguiti da Laboratori esterni specializzati, attrezzati con moderni strumenti.
Laboratorio Controllo Qualità.

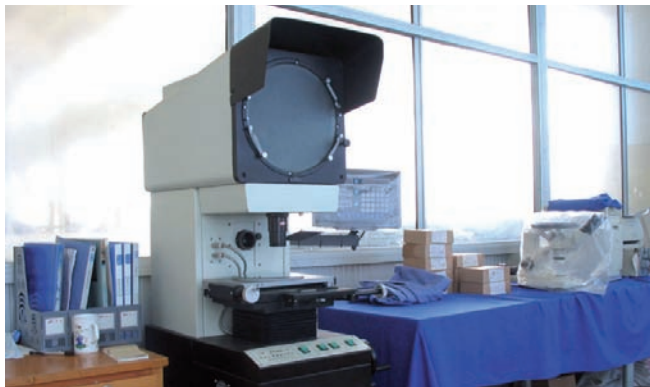
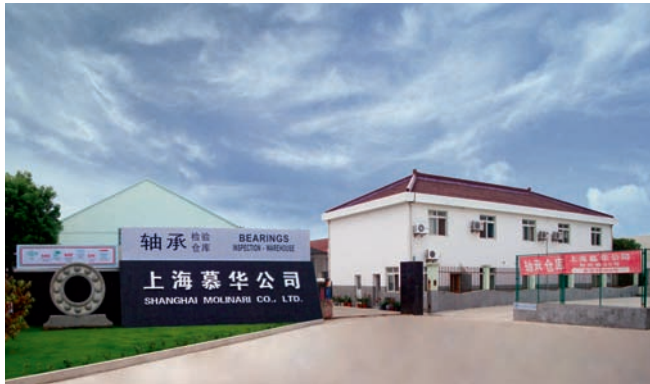

Asia quality control

... an additional series of tests are conducted by specialised third party Laboratories using the latest instruments.
Quality Control Laboratory.

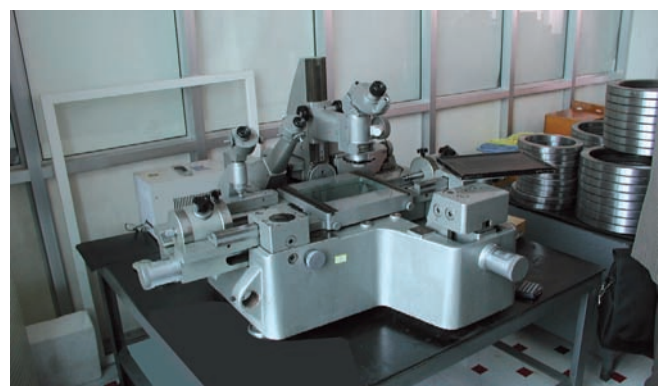

Cuscinetti per applicazioni “bassa rumorosità”

Controllo qualità Italia

... centro di controllo per la qualità nella nostra sede in ITALIA.

... uno staff di Ingegneri tecnici della Qualità, al vostro servizio.



Italy quality control

... a quality control centre is located in our ITALY headquarters.

... our staff of technical engineers at yr service, for Quality.

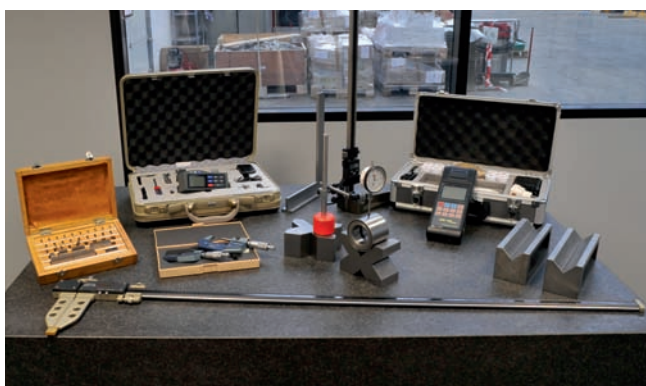

Documentazione qualità

Quality documentations



ELECTRICAL MOTORS STANDARD

ISIR

Reporto di controllo di prima campionatura
Initial Sample Inspection Report

N° 002/09
Pagina n° 1 di 2

Posizione Key	Dimensione nominale Specific material Nominal dimension Material specification	Unità di misura Unit of measure	Tolleranze Tolerances
1	D.e. Φ 30	mm	0/-0.009
2	Foro d.i. Φ 10	mm	0/-0.009
3	Altezza 9	mm	0/-0.009
4	Vdp	mm	0.006
5	Vdmp	mm	0.006
6	VDp	mm	0.006
8	Rumorosità	dB	0.007
9	Vibrazioni	µm/s	0.002
10		µm/s	0.002
11		µm/s	0.002
12		µm/s	0.002
13		µm/s	0.002
14		µm/s	0.002
15		µm/s	0.002

Posizione Key	Dimensione nominale Specific material Nominal dimension Material specification	Unità di misura Unit of measure	Tolleranze Tolerances	Risultati della misurazione Measurement results										Esito Result	Verifica Control		
				Assunto 6	Assunto 7	Assunto 8	Assunto 9	Assunto 10	Assunto 11	Assunto 12	Assunto 13	Assunto 14	Assunto 15				
1	D.e. Φ 30	mm	0/-0.009	29.995	29.997	29.999	29.996	29.999	29.997	29.997	29.997	29.997	29.997	29.997	29.997	OK	OK
2	Foro d.i. Φ 10	mm	0/-0.008	9.996	9.995	9.999	9.995	9.999	9.997	9.997	9.997	9.997	9.997	9.997	9.997	OK	OK
3	Altezza 9	mm	0/-0.120	8.965	8.965	8.963	8.975	8.975	8.975	8.975	8.975	8.975	8.975	8.975	8.975	OK	OK
4	Vdp	mm	0.006	0.006	0.006	0.006	0.006	0.006	0.006	0.006	0.006	0.006	0.006	0.006	0.006	OK	OK
5	Vdmp	mm	0.006	0.006	0.006	0.006	0.006	0.006	0.006	0.006	0.006	0.006	0.006	0.006	0.006	OK	OK
6	VDp	mm	0.006	0.006	0.006	0.006	0.006	0.006	0.006	0.006	0.006	0.006	0.006	0.006	0.006	OK	OK
8	Rumorosità	dB	0.007	0.007	0.007	0.007	0.007	0.007	0.007	0.007	0.007	0.007	0.007	0.007	0.007	OK	OK
9	Vibrazioni	µm/s	0.002	0.002	0.002	0.002	0.002	0.002	0.002	0.002	0.002	0.002	0.002	0.002	0.002	OK	OK
10		µm/s	0.002	0.002	0.002	0.002	0.002	0.002	0.002	0.002	0.002	0.002	0.002	0.002	0.002	OK	OK
11		µm/s	0.002	0.002	0.002	0.002	0.002	0.002	0.002	0.002	0.002	0.002	0.002	0.002	0.002	OK	OK
12		µm/s	0.002	0.002	0.002	0.002	0.002	0.002	0.002	0.002	0.002	0.002	0.002	0.002	0.002	OK	OK
13		µm/s	0.002	0.002	0.002	0.002	0.002	0.002	0.002	0.002	0.002	0.002	0.002	0.002	0.002	OK	OK
14		µm/s	0.002	0.002	0.002	0.002	0.002	0.002	0.002	0.002	0.002	0.002	0.002	0.002	0.002	OK	OK
15		µm/s	0.002	0.002	0.002	0.002	0.002	0.002	0.002	0.002	0.002	0.002	0.002	0.002	0.002	OK	OK

BEARING TESTING REPORT

DATA CONTROLLO: Marzo 2009

PO (ABEC 1) QTA CONTROLLATA: 1 x brand

ISB Electrical Motors Standard

FORNITORE: Cascinetto E205 ZZ

PRECISIONE: B Item - ISB

RELEVANZA: B Item

ITEM: HARDNESS (HRC)

ITEM	STANDARD	A Item	B Item	ISB
60 ± 53	62.1	62.1	64.1	61.6
61 ± 14	60.8	62.5	64.1	61.6
60 ± 53	24.990	24.991	24.992	24.992
25.090	24.989	24.990	24.990	24.990
24.990	0.003	0.002	0.002	0.002
0.008	0.002	0.002	0.002	0.002
0.008	51.997	51.991	51.991	51.996
52.090	51.995	51.991	51.991	51.993
51.997	0.003	0.004	0.004	0.005
0.030	0.007	0.019	0.009	0.010
0.030	0.003	0.004	0.004	0.004
0.033	0.003	0.007	0.008	0.007
0.033	0.004	0.007	0.007	0.015
0.025	0.016	0.012	0.012	0.020
0.005+0.030	14.975	14.978	14.984	14.984
15.090	14.975	14.973	14.981	14.982
14.990	0.003	0.010	0.005	0.004
0.020	14.970	0.010	14.979	14.979
15.090	14.968	14.970	14.975	14.978
14.990	0.007	0.010	0.008	0.003
0.020	39	35	34	38
40 (°)	145	85	25	45
80 (dB)	40	30	35	39
60 (°)	50	0.38	0.09	0.21
45 (°)	0.39	0.21	0.29	-
0.24	-	-	-	-

BEARING TESTING REPORT

DATA CONTROLLO: Marzo 2009

PO (ABEC 1) QTA CONTROLLATA: 1 x brand

ISB Electrical Motors Standard

FORNITORE: Cascinetto E205 ZZ

PRECISIONE: B Item - ISB

RELEVANZA: B Item

ITEM: DIMENSIONS PRECISION

ITEM: RUNNING ACCURACY

ITEM: NOISE & VIBRATION

ITEM: ROUGHNESS

ITEM: CONTACT SURFACE

ITEM: MATERIAL COMPOSITION



Cuscinetti per applicazioni "bassa rumorosità"

Settori d'applicazione

Application fields



Casa
House

Ufficio
Office



Veicoli
Vehicle

Macchine
Machinery



Altro
Others

Gruppi
elettropompa e
motopompa
Motor and
engine driver
pumps



Casa

Condizionatori
Lavatrici
Lavastoviglie
Ventilatori
Micronde
Frigoriferi
Aspirapolveri
Frullatori

House

*Air conditioners
Washing machines
Dishwashers
Electric fans
Microwave oven
Refrigerators
Vacuum cleaners
Mixers*

Ufficio

Stampanti
Fax
Fotocopiatrici
Calcolatrici

Office

*Graph plotters
Fax machines
Duplication machines
Calculating*

Veicoli

Utensili elettrici
Dispositivi di trasmissione
Automobili
Motociclette

Vehicle

*Electric tools
Transmission devices
Cars
Motorcycles*

Macchine

Macchine
Macchine imballaggio
Macchine per il trasporto
Mandrini ad alta frequenza
Macchine tessili
Macchine automatizzate

Machines

*Machinery
Packaging machinery
Transport machinery
High frequency spindle
Textile machinery
Robot*





















Altro

Sollevatori automatici
Spazzolini elettrici
Piccoli strumenti medici
Rasoi elettrici
Pompe
Encoder
Motori elettrici
Riduttori

Others

*Automatic elevators
Electric toothbrush
Small medical instruments
Electric razor
Pumps
Encoder
Electric motors
Gear reducers*

Indice del catalogo	Pagina	Catalogue index	Page
Introduzione.....	1	<i>Introduction.....</i>	<i>1</i>
1. Materiali.....	2	<i>1. Materials.....</i>	<i>2</i>
2. Lubrificazione.....	3	<i>2. Lubrication.....</i>	<i>3</i>
2.1 Grassi utilizzati.....	4	<i>2.1 Grease used.....</i>	<i>4</i>
3. Classi di precisione.....	5	<i>3. Precision class.....</i>	<i>5</i>
3.1 Classe di precisione ABEC-1.....	6	<i>3.1 Precision class ABEC-1.....</i>	<i>6</i>
3.2 Classe di precisione ABEC-3.....	7	<i>3.2 Precision class ABEC-3.....</i>	<i>7</i>
3.3 Classe di precisione ABEC-5.....	8	<i>3.3 Precision class ABEC-5.....</i>	<i>8</i>
3.4 Classe di precisione ABEC-7.....	9	<i>3.4 Precision class ABEC-7.....</i>	<i>9</i>
4. Giuoco radiale.....	10	<i>4. Radial clearance.....</i>	<i>10</i>
5. Vibrazioni e rumorosità.....	11	<i>5. Vibrations and noise.....</i>	<i>11</i>
6. Suffissi dei cuscinetti.....	12	<i>6. Bearings suffixes.....</i>	<i>12</i>
7. Schermi e tenute.....	12	<i>7. Shields and seals.....</i>	<i>12</i>
8. Dimensioni dei raccordi (smusso).....	13	<i>8. Mounting chamfer dimensions tolerances.....</i>	<i>13</i>
9. Manutenzione.....	14	<i>9. Maintenance.....</i>	<i>15</i>
10. Confezioni ed imballi.....	16	<i>10. Packing.....</i>	<i>16</i>

Prodotti	Pagina	Products	Page
 Serie 600	17	 600 series	17
 Serie 60..	18	 60.. series	18
 Serie 62..	19	 62.. series	19
 Serie 63..	20	 63.. series	20
 Serie 622..	21	 622.. series	21
 Serie 630..	22	 630.. series	22
 Serie 160.. e 161..	23	 160.. and 161.. series	23
 Serie 618.. e 619..	24-25	 618.. and 619.. series	24-25
 Serie 72.. e 73..	26	 72.. and 73.. series	26
 Serie 32.. e 33..	27	 32.. and 33.. series	27



Cuscinetti per applicazioni “bassa rumorosità”



ELECTRICAL **M**OTORS **S**TANDARD

ISB[®], cuscinetti bassa rumorosità...

I cuscinetti **ISB[®] ELECTRICAL MOTORS STANDARD** sono stati appositamente studiati, costruiti e selezionati uno ad uno, per applicazioni dove sono richieste, massima silenziosità e minima vibrazione.

Un pool di aziende, con Sistema di Qualità certificato UNI EN ISO 9001:2000, grazie al loro elevato know-how tecnico ed alla disponibilità di macchine ad avanzata tecnologia, ne controlla attentamente la produzione, garantendo pertanto un prodotto di elevata qualità.

Per cuscinetti con particolari caratteristiche tecniche e costruttive, le stesse aziende dispongono di uffici tecnici in grado di risolvere eventuali problemi derivanti dalla loro progettazione ed applicazione.

ISB[®], low noise ball bearings...

ISB[®] ELECTRICAL MOTORS STANDARD bearings have been carefully manufactured and individually selected for assembly on Electric Motors and other applications where low noise and vibration is of paramount importance.

The production of these bearings is constantly monitored and checked only by companies who have full certification with System Quality UNI EN ISO 9001:2000. This ensures that, thanks to their knowledge and their use of bearings for special applications.

The technical staff of these companies are able to solve any difficulties customers may have arising from the need of bearings for special applications.



Cuscinetti per applicazioni "bassa rumorosità"

1. Materiali

1. Materials

Per la costruzione degli anelli interni ed esterni e delle sfere, viene utilizzato un tipo di acciaio speciale per cuscinetti al cromo di elevata qualità, conforme alle norme ISO e SAE 52100. Qui di seguito sono riportate le specifiche tecniche.

Inner and outer rings, balls and cages are made from a special type of high quality chrome steel in full accordance with ISO and SAE 52100 requirements. See below the technical specifications.

Componenti - Components	Tipo di acciaio - Steel type	Durezza - Hardness
Anello interno - Inner ring	Acciaio al cromo - Chrome steel 100 CR6 (GCr15)	60 / 62,5 (± 0,5) HRC
Anello esterno - Outer ring	Acciaio al cromo - Chrome steel 100 CR6 (GCr15)	60 / 62,5 (± 0,5) HRC
Gabbia - Cage	Acciaio - Steel C40	—
Sfere - Balls*	Acciaio al cromo - Chrome steel 100 CR6 (grado-grade G5)	60/65 (± 0,5) HRC

* Disponibile a richiesta con alto grado di precisione - Available upon request with other precision grade

% Composizione chimica dell'acciaio per cuscinetti - Chemical composition of bearing steel %

Carbonio Carbon C	Silicio Silicon Si	Manganese Manganese Mn	Fosforo Phosphorus P	Zolfo Sulphur S	Cromo Chromium Cr
0,98 ~ 1,10	0,15 ~ 0,30	0,25 ~ 0,45	<0,025	<0,025	1,30 ~ 1,60

Struttura del cuscinetto

Bearing structure

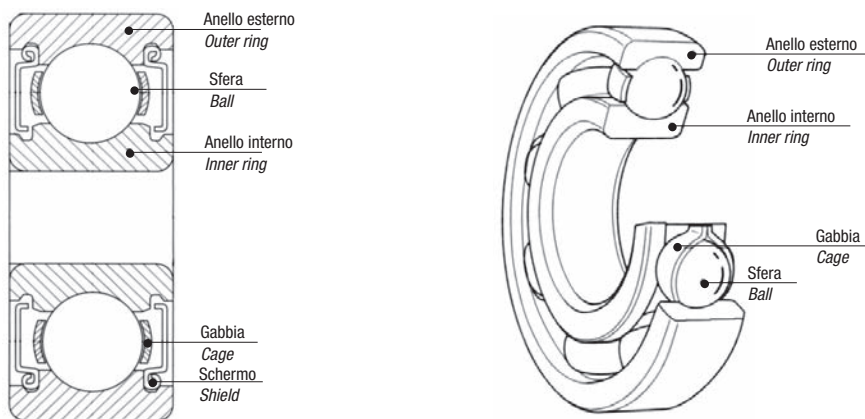

Gabbia

Cage



Gabbia rivettata
Rivet-type cage



Gabbia con linguetta
Tongue-type cage



Gabbia in poliammide
rinforzata con fibra di vetro
Polyamide-type cage
reinforced with glass fiber

2. Lubrificazione

2. Lubrication

I cuscinetti per applicazioni a “bassa rumorosità” sono pre-lubrificati con speciali lubrificanti appositamente studiati per ridurre la frizione ed il calore generato, contenere la rumorosità, proteggere dalle contaminazioni e ridurre i costi di manutenzione per gli utilizzatori finali.

A seconda delle condizioni d’applicazione, della rotazione dell’albero, della temperatura d’esercizio, ecc... è possibile utilizzare lubrificanti diversi come mostrato nella tabella sotto riportata. Nei cuscinetti **ISB® ELECTRICAL MOTORS STANDARD** vengono impiegati i seguenti grassi:

Kyodo Yushi Multitemp e Shell Alvania 2.

Ball bearings for “low noise” applications are pre-lubricated with special lubricants purposely designed to reduce friction and heat, to limit noise, to protect from contamination thus reducing maintenance costs for the end user.

It is possible to use different lubricants depending application conditions.

Please see table below.

*Greases used in **ISB® ELECTRICAL MOTORS STANDARD** bearings are as follows:*

Kyodo Yushi Multitemp and Shell Alvania 2.

Confronto tra lubrificazione a grasso e lubrificazione ad olio

Comparison between grease lubrication and oil lubrication

Descrizione <i>Specification</i>	Lubrificazione a grasso <i>Grease lubrication</i>	Lubrificazione ad olio <i>Oil lubrication</i>
Sede e tenute <i>Housing and seals</i>	Semplice <i>Simple</i>	Attenzione!!! Manutenzione richiesta <i>Careful!!! Maintenance required</i>
Velocità <i>Speed</i>	Velocità massima tra 65% e 80% della lubrificazione ad olio <i>Max speed between 65% and 80% of oil lubrication</i>	Limite di velocità più alto <i>Higher limit speed</i>
Raffreddamento <i>Cooling</i>	Povero <i>Poor</i>	—
Fluidità <i>Fluidity</i>	Povero <i>Poor</i>	Buona <i>Good</i>
Rilubrificazione totale <i>Total re-lubrication</i>	A volte è difficile <i>Sometimes is difficult</i>	Semplice <i>Easy</i>
Rimozione parti esterne <i>Removal of external parts</i>	Rimozione impossibile <i>Impossible removal</i>	Semplice <i>Easy</i>
Contaminazione esterna dovuta alla perdita <i>External contamination due to leakage</i>	Rare contaminazioni da perdite <i>Rare contamination by leakage</i>	In assenza di contromisure ci sono molte perdite. Sconsigliato in caso di contaminazioni esterne. Da evitare <i>Frequent leakage. No suitable if external contamination has to be avoided</i>



Cuscinetti per applicazioni “bassa rumorosità”

2.1. Grassi utilizzati

2.1. Grease used

Produttore <i>Producer</i>	Marca <i>Brand</i>	Origine <i>Base oil</i>	Punto di sgocciolamento °C <i>Drop point °C</i>	Consistenza <i>Consistency</i>	Temperatura d'esercizio °C <i>Operating temperature range °C</i>	Applicazione <i>Application</i>
Exxon	Beacon 325	Grasso sintetico <i>Synthetic grease</i>	193	290	-60 ~ +120	Bassa temperatura <i>Low temperature</i>
	Andok B	Minerale <i>Mineral</i>	260	280	-40 ~ +120	Generica <i>General purpose</i>
	Andok C	Minerale <i>Mineral</i>	≥ 260	205	-20 ~ +120	Generica <i>General purpose</i>
	Andok 260	Minerale <i>Mineral</i>	200	250	-30 ~ +150	Generica <i>General purpose</i>
Kyodo Yushi	Multemp PS2	Diester	189	280	-50 ~ +110	Bassa temperatura <i>Low temperature</i>
	Multemp SRL	Esteri <i>Ester</i>	191	245	-40 ~ +150	Bassa rumorosità <i>Low noise</i>
	Multemp SRH	Esteri <i>Ester</i>	250	201	-40 ~ +150	Bassa temperatura <i>Low temperature</i>
	Multemp SB-M	Olio sintetico <i>Synthetic oil</i>	220	260	-40 ~ +200	Alta velocità e temperatura <i>High speed and temperature</i>
	ET-K	Olio sintetico <i>Synthetic oil</i>	260	300	-40 ~ +200	Alta temperatura <i>High temperature</i>
Kluber	Asonic GLY32	Sintetico <i>Synthetic</i>	190	265-295	-50 ~ +140	Bassa temperatura <i>Low temperature</i>
	Asonik GHY72	Esteri minerale <i>Ester Mineral</i>	250	250-280	-40 ~ +180	Alta temperatura e bassa rumorosità <i>High temperature and low noise</i>
	Isoflex Super LDS18	Diester	190	280	-60 ~ +130	Bassa temperatura <i>Low temperature</i>
	Isoflex LDS18 Special A	Diester	190	280	-60 ~ +130	Bassa temperatura <i>Low temperature</i>
	Isoflex Topas NB52	Idrocarburo sintetico <i>Hydrocarbon synthetic</i>	204	280	-60 ~ +170	Bassa ed alta temperatura <i>Low and high temperature</i>
	Barrierta L55/2	Fluorato <i>Fluorinated</i>	—	280	-35 ~ +260	Bassa ed alta temperatura <i>Low and high temperature</i>
	Barrierta TK44N2	Silicone <i>Silicone</i>	—	—	-60 ~ +230	Bassa ed alta temperatura <i>Low and high temperature</i>
	Isoflex NCA15	Esteri minerale <i>Ester Mineral</i>	180	265-295	-40 ~ +130	Alta velocità <i>High speed</i>
	Asonic HQ72-102	Esteri <i>Ester</i>	240	250-280	-40 ~ +180	Bassa ed alta temperatura e bassa rumorosità <i>Low and high temperature and low noise</i>
	Dow Corning	Molykote 33M	Silicone <i>Silicone</i>	210	260	-70 ~ +180
Molykote 44M		Silicone <i>Silicone</i>	204	260	-40 ~ +200	Alta temperatura <i>High temperature</i>
Molykote 55M		Silicone <i>Silicone</i>	—	—	-55 ~ +165	Basse temperature <i>Low temperature</i>
Shell	Alvania No.2	Minerale <i>Mineral</i>	182	272	-25 ~ +120	Generica <i>General purpose</i>
	Alvania No.3	Minerale <i>Mineral</i>	183	233	-20 ~ +135	Generica <i>General purpose</i>
	Alvania RA	Minerale <i>Mineral</i>	183	252	-25 ~ +120	Generica <i>General purpose</i>
	Alvania EP2	Minerale <i>Mineral</i>	185	276	-10 ~ +100	Generica <i>General purpose</i>
	Dolium R	Minerale <i>Mineral</i>	238	281	-20 ~ +140	Generica <i>General purpose</i>
	Aero Shell NO.5	Minerale <i>Mineral</i>	≥ 260	282	-10 ~ +130	Generica <i>General purpose</i>
	Aero Shell NO.7	Minerale <i>Mineral</i>	≥ 260	288	-70 ~ +150	Bassa temperatura <i>Low temperature</i>
	Aero Shell RLQ2	Minerale <i>Mineral</i>	195	266	-50 ~ +150	Bassa rumorosità ed alta velocità <i>Low noise and high speed</i>
Mobil Oil	Mobilux2	Minerale <i>Mineral</i>	190	280	-20 ~ +120	Generica <i>General purpose</i>
	Mobil 22	Minerale Diester <i>Diester Mineral</i>	192	274	-50 ~ +140	Bassa temperatura <i>Low temperature</i>
	Mobil 28	Idrocarburo sintetico <i>Hydrocarbon synthetic</i>	≥ 260	280	-60 ~ +180	Bassa ed alta temperatura <i>Low and high temperature</i>
	Mobiltemp SHC22	Olio sintetico <i>Synthetic oil</i>	250	265-295	-50 ~ +180	Alta velocità e temperatura <i>High speed and temperature</i>
	Mobiltemp SHC100	Olio sintetico <i>Synthetic oil</i>	250	265-295	-40 ~ +200	Alta velocità e temperatura <i>High speed and temperature</i>
Du Pont	Krytox 240AC	Fluorato <i>Fluorinated</i>	—	282	-35 ~ +280	Alta temperatura <i>High temperature</i>
Caltex	Chevron SRI-2	Minerale <i>Mineral</i>	—	293	-30 ~ +175	Alta temperatura <i>High temperature</i>
Hangu	Hangu#2	Minerale <i>Mineral</i>	—	—	-20 ~ +120	Generica <i>General purpose</i>

3. Classi di precisione

3. Precision class

I cuscinetti **ISB® ELECTRICAL MOTORS STANDARD** sono costruiti con tolleranze di lavorazione conformi alle norme ISO. Normalmente sono costruiti con classe di precisione 6, definita normale, anche se, a richiesta del Cliente, possono essere forniti con maggiori classi di precisione.

ISB® ELECTRICAL MOTORS STANDARD bearings are manufactured with precision class 6 tolerances in accordance with ISO requirements. They can, at Customers request or for special applications, be supplied with a higher precision class.

Standard	Classe di tolleranza / Tolerance class			
ISO	0	6	5	4
DIN	P0	P6	P5	P4
ANSI	ABEC - 1	ABEC - 3	ABEC - 5	ABEC - 7

Simboli

Simboli		Symbols
Diametro nominale del foro	d	Nominal bore diameter
Diametro medio del foro	d_{mp}	Mean bore diameter
Variazione del diametro del foro	V_d	Bore diameter variation
Variazione del diametro medio del foro	V_{dmp}	Mean bore diameter variation
Scostamento del diametro del foro dal valore nominale ($\Delta_{dmp}=dmp-d$)	Δ_{dmp}	Deviation of the mean bore diameter ($\Delta_{dmp}=dmp-d$)
Diametro nominale esterno	D	Nominal outer diameter
Diametro esterno medio	D_{mp}	Mean outer diameter
Variazione del diametro esterno	V_D	Outer diameter variation
Variazione del diametro medio esterno	V_{Dmp}	Mean outer diameter variation
Scostamento del diametro esterno medio ($\Delta_{Dmp}=Dmp-D$)	Δ_{Dmp}	Deviation of the mean outer diameter ($\Delta_{Dmp}=Dmp-D$)
Concetricità di rotazione dell'anello interno del cuscinetto completo (precisione radiale di rotazione)	K_{ia}	Rotation concentricity of the bearing inner ring (run out radial precision)
Concetricità di rotazione dell'anello esterno del cuscinetto completo (precisione radiale di rotazione)	K_{ea}	Concentricity radial run out of assembled bearing outer ring (run out radial precision)
Misura nominale dell'altezza dell'anello interno	B	Nominal height of the inner ring
Misura nominale dell'altezza dell'anello esterno	C	Nominal height of the outer ring
Misura singola dell'altezza dell'anello interno e dell'anello esterno	B_S - C_S	Single height of the inner and outer ring
Scostamento di una singola misura dell'altezza dell'anello interno rispetto alla dimensione nominale ($\Delta_{Bs}=Bs-B$)	Δ_{Bs}	Inner ring single width deviation ($\Delta_{Bs}=Bs-B$)
Scostamento di una singola misura dell'altezza dell'anello esterno rispetto alla dimensione nominale ($\Delta_{Cs}=Cs-C$)	Δ_{Cs}	Deviation of outer ring single width ($\Delta_{Cs}=Cs-C$)
Variazione della larghezza dell'anello (differenza tra i valori massimi e minimi delle singole misure dell'anello interno ed esterno)	V_{Bs} - V_{Cs}	Inner and outer ring width variation
Difetto di quadratura delle facciate rispetto al foro dell'anello interno	S_d	Side face run out with reference to bore of the inner ring
Variazione dell'inclinazione cilindrica esterna rispetto alla superficie laterale dell'anello esterno	S_D	Variation of the inclination of outside cylindrical surface to outer ring side face
Planarità di rotazione della superficie laterale dell'anello interno rispetto alla pista nel cuscinetto radiale completo (precisione assiale di rotazione)	S_{ia}	Side face run out of assembled inner ring with reference to raceway
Planarità di rotazione della superficie laterale dell'anello esterno rispetto alla pista nel cuscinetto radiale completo (precisione assiale di rotazione)	S_{ea}	Side face run out of assembled outer ring with reference to raceway



Cuscinetti per applicazioni "bassa rumorosità"

3.1 Classe di precisione ABEC-1

3.1 Precision class ABEC-1

Anello interno / Inner ring

μm.

d (mm)		Δ_{dmp}		V_{dp}			V_{dmp}	K_{ia}	Δ_{Bs}		V_{Bs}
				Serie diametrali Diameter series							
				9	0,1	2,3,4					
oltre over	fino a up to	max	min	max			max	max	max	min	max
0,6	2,5	0	-8	10	8	6	6	10	0	-40	12
2,5	10	0	-8	10	8	6	6	10	0	-120	15
10	18	0	-8	10	8	6	6	10	0	-120	20
18	30	0	-10	13	10	8	8	13	0	-120	20
30	50	0	-12	15	12	9	9	15	0	-120	20
50	80	0	-15	19	19	11	11	20	0	-150	25

Anello esterno / Outer ring

μm.

D (mm)		Δ_{Dmp}		V_{Dp}				V_{Dmp}	K_{ea}	Δ_{Cs}		V_{Cs}
				Cuscinetti aperti Open bearings			Cuscinetti chiusi Closed bearings					
				Serie diametrali Diameter series								
				9	0,1	2,3,4	2,3,4					
oltre over	fino a up to	max	min	max			max	max	max	min	max	
2,5	6	0	-8	10	8	6	10	6	15	Uguale a Δ_{Bs} e V_{Bs} per anello interno dello stesso cuscinetto Identical to Δ_{Bs} and V_{Bs} of the inner ring of the relevant bearing		
6	18	0	-8	10	8	6	10	6	15			
18	30	0	-9	12	9	7	12	7	15			
30	50	0	-11	14	11	8	16	8	20			
50	80	0	-13	16	13	10	20	10	25			
80	120	0	-15	19	19	11	26	11	35			
120	150	0	-18	23	23	14	30	14	40			

3.2 Classe di precisione ABEC-3

3.2 Precision class ABEC-3

Anello interno / Inner ring

μm.

d (mm)		Δ_{dmp}		V_{dp}			V_{dmp}	K_{ia}	Δ_{Bs}		V_{Bs}
				Serie diametrali Diameter series							
				9	0,1	2,3,4					
oltre over	fino a up to	max	min	max			max	max	max	min	max
0,6	2,5	0	-7	9	7	5	5	5	0	-40	12
2,5	10	0	-7	9	7	5	5	6	0	-120	15
10	18	0	-7	9	7	5	5	7	0	-120	20
18	30	0	-8	10	8	6	6	8	0	-120	20
30	50	0	-10	13	10	8	8	10	0	-120	20
50	80	0	-12	15	15	9	9	10	0	-150	25

Anello esterno / Outer ring

μm.

D (mm)		Δ_{Dmp}		V_{Dp}				V_{Dmp}	K_{ea}	Δ_{Cs}		V_{Cs}
				Cuscinetti aperti Open bearings		Cuscinetti chiusi Closed bearings						
				Serie diametrali Diameter series								
oltre over	fino a up to	max	min	9	0,1	2,3,4	2,3,4	max	max	max	min	max
2,5	6	0	-7	9	7	5	9	5	8	Uguale a Δ_{Bs} e V_{Bs} per anello interno dello stesso cuscinetto Identical to Δ_{Bs} and V_{Bs} of the inner ring of the relevant bearing		
6	18	0	-7	9	7	5	9	5	8			
18	30	0	-8	10	8	6	10	6	9			
30	50	0	-9	11	9	7	13	7	10			
50	80	0	-11	14	11	8	16	8	13			
80	120	0	-13	16	16	10	20	10	18			
120	150	0	-15	19	19	11	25	11	20			



Cuscinetti per applicazioni "bassa rumorosità"

3.3 Classe di precisione ABEC-5

3.3 Precision class ABEC-5

Anello interno / Inner ring

d (mm)		Δ_{dmp}		V_{dp}		V_{dmp}	K_{ia}	S_d	S_{ia}	Δ_{Bs}		V_{Bs}
				Serie diametrali Diameter series								
				9	0,1,2,3,4							
oltre over	fino a up to	max	min	max		max	max	max	max	max	min	max
0,6	2,5	0	-5	5	4	3	4	7	7	0	-40	5
2,5	10	0	-5	5	4	3	4	7	7	0	-40	5
10	18	0	-5	5	4	3	4	7	7	0	-80	5
18	30	0	-6	6	5	3	4	8	8	0	-120	5
30	50	0	-8	8	6	4	5	8	8	0	-120	5
50	80	0	-9	9	7	5	5	8	8	0	-150	6

μm.

Anello esterno / Outer ring

D (mm)		Δ_{Dmp}		V_{Dp}		V_{Dmp}	K_{ea}	S_D	S_{ea}	Δ_{Cs}		V_{Cs}
				Serie diametrali Diameter series								
				9	0,1,2,3,4							
oltre over	fino a up to	max	min	max		max	max	max	max	max	min	max
2,5	6	0	-5	5	4	3	5	8	8	Uguale a Δ_{Bs} e V_{Bs} per anello interno dello stesso cuscinetto Identical to Δ_{Bs} and V_{Bs} of the inner ring of the relevant bearing		
6	18	0	-5	5	4	3	5	8	8			
18	30	0	-6	6	5	3	6	8	8			
30	50	0	-7	7	5	4	7	8	8			
50	80	0	-9	9	7	5	8	8	10			
80	120	0	-10	10	8	5	10	9	11			
120	150	0	-11	11	8	6	11	10	13			

μm.

3.4 Classe di precisione ABEC-7

3.4 Precision class ABEC-7

Anello interno/ Inner ring

μm.

d (mm)		Δ_{dmp}		Δ_{ds}		V_{dp}		V_{dmp}	K_{ia}	S_d	S_{ia}	Δ_{Bs}		V_{Bs}
						Serie diametrali Diameter series								
						7,8,9	1,7,2,3,4							
oltre over	fino a up to	max	min	max	min	max	max	max	max	max	max	min	max	
0,6	2,5	0	-4	0	-4	4	3	2	2,5	3	3	0	-40	2,5
2,5	10	0	-4	0	-4	4	3	2	2,5	3	3	0	-40	2,5
10	18	0	-4	0	-4	4	3	2	2,5	3	3	0	-80	2,5
18	30	0	-5	0	-5	5	4	2,5	3	4	4	0	-120	2,5
30	50	0	-6	0	-6	6	5	3	4	4	4	0	-120	3
50	80	0	-7	0	-7	7	5	3,5	4	5	5	0	-150	4

Anello esterno / Outer ring

μm.

D (mm)		Δ_{Dmp}		Δ_{Ds}		V_{Dp}		V_{Dmp}	K_{ea}	S_D	S_{ea}	Δ_{Cs}		V_{Cs}
						Serie diametrali Diameter series								
						7,8,9	1,7,2,3,4							
oltre over	fino a up to	max	min	max	min	max	max	max	max	max	max	min	max	
2,5	6	0	-4	0	-4	4	3	2	3	4	5	Uguale a Δ_{Bs} e V_{Bs} per anello interno dello stesso cuscinetto Identical to Δ_{Bs} and V_{Bs} of the inner ring of the relevant bearing		
6	18	0	-4	0	-4	4	3	2	3	4	5			
18	30	0	-5	0	-5	5	4	2,5	4	4	5			
30	50	0	-6	0	-6	6	5	3	5	4	5			
50	80	0	-7	0	-7	7	5	3,5	5	4	5			
80	120	0	-8	0	-8	8	6	4	6	5	6			
120	150	0	-9	0	-9	9	7	5	7	5	7			



4. Giuoco radiale

Il giuoco radiale dei cuscinetti è determinato dallo spostamento in senso radiale (da una parte all'altra) dell'anello interno rispetto all'anello esterno.

I cuscinetti **ISB® ELECTRICAL MOTORS STANDARD** vengono costruiti con giuoco radiale “normale” ed utilizzati per comuni impieghi, garantiscono parametri soddisfacenti di funzionamento.

Il giuoco radiale, se diverso da quello “normale”, viene evidenziato con una sigla che segue quella identificativa del tipo di cuscinetto (esempio: 6005 C3). La tabella seguente fornisce i valori dei giuochi radiali.

4. Radial clearance

The radial clearance of bearings is determined by the radial movement (from one side to the other between the inner ring and the outer track).

The **ISB® ELECTRICAL MOTORS STANDARD** bearings are constructed with “normal” radial clearance, in order to satisfy common applications.

If the radial play differs from the standard, it can be recognized with a suffix that identifies the type of bearing (example: 6005 C3). The following table shows the values for radial clearances.

Tabella giuoco radiale dei cuscinetti a sfera

Tables of radial clearance for ball bearings

µm.

Diametro del foro (mm) Bore diameter (mm)		C2		Normale Normal		C3		C4		C5	
Oltre Over	Fino a Up to	Min	Max	Min	Max	Min	Max	Min	Max	Min	Max
2,5	10	0	7	2	13	8	23	14	29	20	37
10	18	0	9	3	18	11	25	18	33	25	45
18	24	0	10	5	20	13	28	20	36	28	48
24	30	1	11	5	20	13	28	23	41	30	53
30	40	1	11	6	20	15	33	28	46	40	64
40	50	1	11	6	23	18	36	30	51	45	73
50	65	1	15	8	28	23	43	38	61	55	90

5. Vibrazioni e rumorosità

5. Vibrations and noise

I cuscinetti **ISB® ELECTRICAL MOTORS STANDARD** vengono costruiti seguendo i valori di rumorosità e vibrazione indicati nelle sotto riportate tabelle; in particolare possono essere prodotti sia in esecuzione "Low Noise-Z₃ V₃" sia in esecuzione "Low Noise Plus - Zp Vp".

ISB® ELECTRICAL MOTORS STANDARD bearings have been manufactured in accordance with the values shown in the tables below. In particular they are available in Z₃-V₃ noiseless "Low Noise" or "Zp - Vp Low Noise Plus" version.

Tabella tolleranze delle vibrazioni

Vibrations tolerances table

µm./s

d mm	V			V ₁			V ₂			V ₃			V ₄			Vp		
	Basso Low	Medio Medium	Alto High	Basso Low	Medio Medium	Alto High	Basso Low	Medio Medium	Alto High	Basso Low	Medio Medium	Alto High	Basso Low	Medio Medium	Alto High	Basso Low	Medio Medium	Alto High
3,4	80	44	44	60	35	32	48	26	22	31	16	15	28	10	10	25	10	10
5,6	110	72	60	74	48	40	58	36	30	35	21	18	32	11	11	25	12	10
7,8	130	96	80	92	66	54	72	48	40	44	28	24	38	12	12	35	14	12
9	130	96	80	92	66	54	72	48	40	44	28	24	38	12	12	40	16	14
10	160	120	100	120	80	70	90	60	50	55	35	30	45	14	15	45	22	20
12	160	120	100	120	80	70	90	60	50	55	35	30	45	14	15	45	24	22
15	210	150	120	150	100	85	110	78	60	65	46	35	52	18	18	50	32	26
17	210	150	120	150	100	85	110	78	60	65	46	35	52	25	25	50	35	30
20	260	190	150	180	125	100	130	100	75	80	60	45	60	25	25	60	40	35
22,25	260	190	150	180	125	100	130	100	75	80	60	45	60	30	32	70	40	35
28	260	190	150	180	125	100	130	100	75	80	60	45	60	35	40	55	31	28
30,32	300	240	190	200	150	130	150	120	100	90	75	60	70	35	40	80	50	45
35	300	240	190	200	150	130	150	120	100	90	75	60	70	42	45	80	50	40
40	360	300	260	240	180	160	180	150	130	110	90	80	82	50	50	100	80	60
45	360	300	260	240	180	160	180	150	130	110	90	80	82	60	60	120	80	70
50	420	320	320	280	200	200	210	160	160	125	100	100	95	70	70	140	100	80

Tabella tolleranze della rumorosità

Noise tolerances table

dB

d mm	Serie diametrali (60...) Diameter series (60...)					Serie diametrali (62...) Diameter series (62...)						Serie diametrali (63...) Diameter series (63...)					
	Z	Z ₁	Z ₂	Z ₃	Zp	Z	Z ₁	Z ₂	Z ₃	Z ₄	Zp	Z	Z ₁	Z ₂	Z ₃	Z ₄	Zp
3	35	34	32	28	26	36	35	32	30	-	26	37	36	33	31	-	26
4	35	34	32	28	26	36	35	32	30	-	26	37	36	33	31	-	26
5	37	36	34	30	26	38	37	34	32	-	26	39	37	35	33	-	26
6	37	36	34	30	22	38	37	34	32	-	23	39	37	35	33	-	24
7	39	38	35	31	22	40	38	36	34	-	23	-	-	-	-	-	24
8	39	38	35	31	23	40	38	36	34	-	24	-	-	-	-	-	25
9	41	40	36	32	24	42	40	37	35	-	25	-	-	-	-	-	26
10	43	42	38	33	24	44	42	39	35	30	25	46	44	40	37	32	26
12	44	43	39	34	26	45	43	39	35	30	27	47	45	40	37	32	28
15	45	44	40	35	28	46	44	41	36	31	29	48	46	42	38	33	30
17	46	44	40	35	31	47	45	41	36	31	32	49	47	42	38	33	33
20	47	45	41	36	34	48	46	42	38	33	35	50	48	43	39	34	36
22	47	45	41	36	35	48	46	42	38	33	36	50	48	43	39	34	35
25	48	46	42	38	35	49	47	43	40	36	36	51	49	44	41	37	39
28	49	47	43	39	36	50	48	44	41	37	37	52	50	45	42	38	37
30	49	47	43	39	37	50	48	44	41	37	38	52	50	45	42	38	40
32	50	48	44	40	38	51	49	45	42	38	39	53	51	46	43	39	39
35	51	49	45	41	40	52	50	46	43	39	40	54	52	47	44	40	42
40	53	51	46	42	42	54	52	47	44	40	42	56	54	49	45	41	43
45	55	53	48	45	43	56	54	49	46	43	43	58	56	51	47	44	42
50	57	54	50	47	44	58	55	51	48	45	44	60	57	53	49	46	43
55	59	56	52	49	45	60	57	53	50	47	45	62	59	54	51	48	47
60	61	58	54	51	47	62	59	54	51	48	47	64	61	56	53	50	48



Cuscinetti per applicazioni “bassa rumorosità”

6. Suffissi dei cuscinetti

6. Bearings suffixs

Schermo in metallo non strisciante da un lato del cuscinetto	Z	Metal shield at one side of the bearing
Schermo in metallo non strisciante da ambo i lati del cuscinetto	ZZ	Metal shield at both sides of the bearing
Guarnizione in gomma strisciante da un lato del cuscinetto	RS	Rubber seal at one side of the bearing
Guarnizione in gomma strisciante da ambo i lati del cuscinetto	2RS	Rubber seal at both sides of the bearing
Guarnizione in gomma a basso attrito rinforzata con un lamierino da un lato del cuscinetto	RZ	Low friction rubber seal reinforced with steel, at one side of the bearing
Guarnizione in gomma a basso attrito rinforzata con un lamierino da ambo i lati del cuscinetto	2RZ	Low friction rubber seal reinforced with steel, at both sides of the bearing
Guarnizione in gomma a medio attrito	2RV	Medium friction rubber seals

7. Schermi e tenute

7. Shields and seals

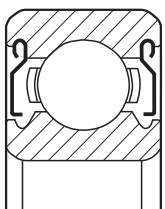
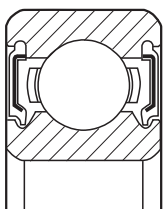
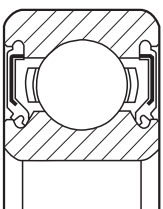
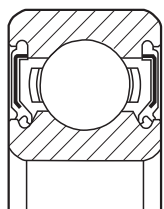
Marca e descrizione Brand and specification	Schermato - Shielded		Con tenuta - Sealed	
	Senza contatto Non-contact type	Senza contatto Non-contact type	A contatto Contact type	Tipo “bassa torsione” “Low torque” type
ISB	ZZ	2RZ	2RS	2RV
NSK	ZZ	W	DDU	DDW
NTN	ZZ	LLB	LLU	LLH
Struttura Structure				
Torsione Torque	Basso Low	Basso Low	Piuttosto alto Rather high	Medio Medium
Resistente alla polvere Dust proofing	Molto buono Very good	Meglio del ZZ Better than ZZ-type	Eccellente Excellent	Molto meglio del 2RZ Much better than 2RZ-type
Resistenza all'acqua Water proofing	Povero Poor	Povero Poor	Molto buono Very good	Molto buono Very good
Capacità di alta velocità High speed capacity	Come il tipo aperto Same as open type	Come il tipo aperto Same as open type	Limitato dall'anello di contatto Limited by contact seals	Molto meglio del 2RS Much better than 2RS-type
Temperatura consentita Allowable temperature range	Dipende dal lubrificante Depends on lubricant	-25 °C ~ +120 °C	-25 °C ~ +110 °C	-25 °C ~ +120 °C

8. Dimensioni dei raccordi (smusso)

r_1, r_3 = smussi in direzione radiale
 r_2, r_4 = smussi in direzione assiale
 $r_s \text{ min}$ = simbolo limite massimo smussi r_1, r_2, r_3, r_4 ,
 $r_{1S} \text{ max}, r_{3S} \text{ max}$ = dimensione massima in direzione radiale
 $r_{2S} \text{ max}, r_{4S} \text{ max}$ = dimensione massima in direzione assiale

Dimensioni limite raccordi per cuscinetti radiali e assiali

Diametro del foro Bore diameter			Cuscinetti radiali Radial bearings		Cuscinetti assiali Thrust bearings
rs min	d		r1s, r3s max	r2s, r4s max	r1s, r2s max
	oltre over	fino a up to			
0,1	-	-	0,2	0,4	0,2
0,15	-	-	0,3	0,6	0,3
0,2	-	-	0,5	0,8	0,5
0,3	-	40	0,6	1	0,8
	40	-	0,8	1	0,8
0,6	-	40	1	2	1,5
	40	-	1,3	2	1,5
1	-	50	1,5	3	2,2
	50	-	1,9	3	2,2
1,1	-	120	2	3,5	2,7
	120	-	2,5	4	2,7
1,5	-	120	2,3	4	3,5
	120	-	3	5	3,5
2	-	80	3	4,5	4
	220	-	3,8	6	4
	80	220	3,5	5	4
2,1	-	100	3,8	6	4,5
	-	280	4	6,5	4,5
	280	-	4,5	7	4,5
2,5	100	280	4,5	6	-
	280	-	5	7	-
3	-	280	5	8	5,5
	280	-	5,5	8	5,5
4	-	-	6,5	9	6,5
5	-	-	8	10	8
6	-	-	10	13	10
7,5	-	-	12,5	17	12,5
9,5	-	-	15	19	15
12	-	-	18	24	18
15	-	-	21	30	21
19	-	-	25	38	25

8. Mounting chamfer dimensions tolerances

r_1, r_3 = chamfer dimension in radial direction
 r_2, r_4 = chamfer dimension in axial direction
 $r_s \text{ min}$ = general symbol for minimum limit r_1, r_2, r_3, r_4 ,
 $r_{1S} \text{ max}, r_{3S} \text{ max}$ = maximum dimension in radial direction
 $r_{2S} \text{ max}, r_{4S} \text{ max}$ = maximum dimension in axial direction

Mounting chamfer dimension limits for radial and thrust bearings

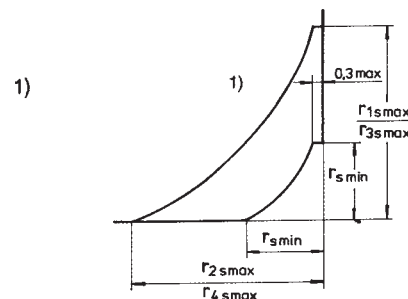
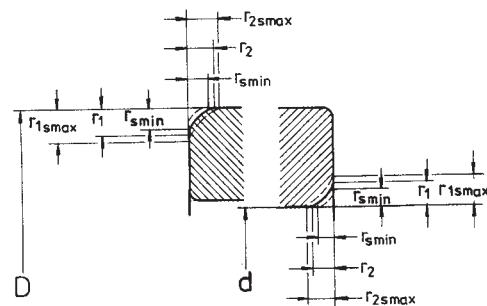
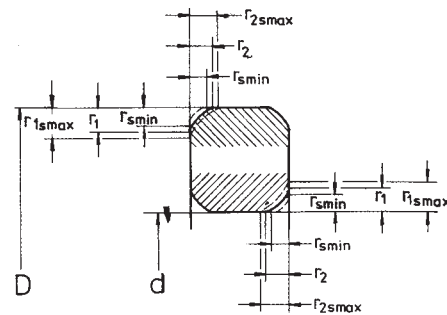

1) Solo per $d < 30 \text{ mm}$
 1) Only for $d < 30 \text{ mm}$



9. Manutenzione

ANOMALIE NEL FUNZIONAMENTO DI UN CUSCINETTO: POSSIBILI CAUSE ED AZIONI CORRETTIVE

ANOMALIA	POSSIBILI CAUSE	AZIONI CORRETTIVE
Forte suono metallico	Carico anomalo	Selezionare con maggiore cura l'accoppiamento, il giuoco interno, il precarico, la posizione dello spallamento della sede, ecc.
	Montaggio non corretto	Migliorare la precisione di lavorazione, l'allineamento dell'albero e dell'alloggiamento, il metodo di montaggio
	Lubrificante inadeguato e/o insufficiente	Selezionare un lubrificante migliore od effettuare rabbocchi
	Giuoco eccessivo	Selezionare un cuscinetto di classe più silenziosa oppure a giuoco ridotto
Forte suono regolare	Contatto tra le parti rotanti	Modificare la tenuta del labirinto, ecc.
	Incrinature, corrosione o abrasioni sulle piste di rotolamento	Sostituire o lavare accuratamente il cuscinetto, migliorare il sistema di tenuta ed usare lubrificanti puliti
	Brinellatura	Sostituire il cuscinetto, maneggiarlo e montarlo con cura
Suono irregolare	Saldatura sulla pista di rotolamento	Sostituire il cuscinetto
	Giuoco eccessivo	Selezionare con maggiore cura l'accoppiamento, il giuoco interno, il precarico
	Penetrazione di particelle estranee	Sostituire o lavare accuratamente il cuscinetto, migliorare il sistema di tenuta ed usare lubrificanti puliti
Incremento irregolare della temperatura	Cricche o saldature sui corpi volenti	Sostituire il cuscinetto
	Eccessiva quantità di lubrificante	Ridurre il quantitativo, selezionare un grasso più consistente
	Lubrificante inadeguato ed insufficiente	Selezionare un lubrificante migliore od effettuare rabbocchi
	Carico anomalo	Selezionare con maggiore cura l'accoppiamento, il giuoco interno, il precarico, la posizione dello spallamento della sede, ecc.
	Montaggio non corretto	Migliorare la precisione di lavorazione, l'allineamento dell'albero e dell'alloggiamento, il metodo di montaggio
Vibrazioni (precisione assiale di rotazione)	Scorrimento relativo delle superfici accoppiate, eccessivo attrito derivato dalle tenute	Modificare o sostituire le tenute, sostituire il cuscinetto, selezionare con maggiore cura l'accoppiamento ed il metodo di montaggio
	Brinellatura	Sostituire il cuscinetto, maneggiarlo e montarlo con cura
	Sfaldatura	Sostituire il cuscinetto
	Montaggio non corretto	Migliorare l'ortogonalità tra l'albero e lo spallamento dell'alloggiamento od il piano di appoggio del distanziale.
Perdite od alterazione di colore del lubrificante	Penetrazione di particelle estranee	Sostituire o lavare accuratamente il cuscinetto, migliorare il sistema di tenuta ed usare lubrificanti puliti
	Lubrificante in eccesso	Ridurre il quantitativo, selezionare un grasso più consistente Sostituire il cuscinetto od il lubrificante Pulire l'alloggiamento e le parti adiacenti

9. Maintenance

ANOMALIES IN THE WORKING OF A BEARING: POSSIBLE CAUSES AND CORRECTIVE ACTIONS

ANOMALY	POSSIBLE CAUSES	CORRECTIVE ACTIONS
Strong clang	Anomalous load	To select more carefully the fit, the internal clearance, the preloading, the position of housing shoulder
	Incorrect assembling	To improve the precision of the manufacturing, the alignment of the shaft and of the housing, the assembling method
	Inadequate or insufficient lubricant	To select a better lubricant or to replenish the lubricant
	Excessive clearance	To select a bearing of a more silent class or with reduced clearance
	Contact between the rotating parts	To modify the labyrinth seal etc
Strong regular sound	Cracks, corrosion or abrasion on the raceways	To substitute or wash accurately the bearing, to improve the seal system and use clean lubricants
	Pitting	To substitute the bearing, handle and assemble it with care
	Welding on the raceways	To substitute the bearing
Irregular sound	Excessive clearance	To select more carefully the fit, the internal clearance, the preloading
	Penetration of extraneous particles	To substitute or wash accurately the bearing, to improve the seal system and use clean lubricant
	Cracks or wildings on the rolling elements	To substitute the bearing
Irregular increase of the temperature	Excessive quantity of lubricant	To reduce the quantity, to select a grease more consistency
	Inadequate or insufficient lubricant	To select a better lubricant or to replenish the lubricant
	Anomalous load	To select more carefully the fit, the internal clearance, the preloading, the position of housing shoulder
	Incorrect assembling	To improve the precision of the manufacturing, the alignment of the shaft and of the housing, the assembling method
	Relative sliding of connected surface, excessive friction of the seals	To modify or substitute the seals, to substitute the bearing, to select more carefully the fit and the assembling method
Vibrations (running axial accuracy)	Pitting	To substitute the bearing, handle and assemble it with care
	Flaking off	To substitute the bearing
	Incorrect assembling	To improve the orthogonality between the shaft and the housing shoulder or the support surface of the space collar
	Penetration of extraneous particles	To substitute or wash accurately the bearing, to improve the seal system and use clean lubricant
Losses or alteration of the colour of the lubricant	Lubricant in excess	To reduce the quantity, to select a grease more consistency To substitute the bearing or the lubricant To clean the housing and the contiguous part

10. Confezioni ed imballi

Tutti i cuscinetti **ISB® ELECTRICAL MOTORS STANDARD** possono essere forniti in scatole da 1 singolo pezzo, da 5 o 10 pezzi e nel formato industriale.

Su ogni scatola viene apposto il codice a barre, identificativo del prodotto, per la reperibilità del lotto.

Confezioni singole

Il Cliente riceverà le singole scatole al cui interno il pezzo è avvolto con una particolare carta che lo protegge dall'umidità, dalla polvere, e che mantiene il lieve strato di olio di cui è ricoperto esternamente il cuscinetto.

Confezioni industriali

Per le richieste di grosse quantità si utilizza il formato industriale: 10 cuscinetti alla volta vengono avvolti con la carta speciale (sopra descritta) e ordinati in una scatola in cartone a sua volta contenente un altro foglio di carta speciale. I cartoni, per evitare danneggiamenti al prodotto durante il trasporto, sono disponibili in 2 diverse dimensioni in modo tale da adattarsi perfettamente alle quantità richieste dal Cliente:

Cartone tipo A 19x25x16,5 cm

Cartone tipo B 37,5x25x16,5 cm.

Imballaggio per il trasporto

Le scatole contenenti i cuscinetti (in scatole singole o solo avvolti nella carta) vengono disposte su pallets di dimensioni standard secondo le norme europee (Euro Pallet). Infine il tutto viene incelofanato e reggiato per agevolarne il trasporto.

10. Packing

All **ISB® ELECTRICAL MOTORS STANDARD** bearings can be supplied in individual boxes, packed in 5's or 10's or in the case of bulk orders in industrial packing. Every box is coded to identify the product and facilitate full monitoring of production.

Individual Package

The Customer will receive the oil coated bearing wrapped with special paper to protect it from humidity and dust and in an individual box.

Industrial Packaging

Industrial packaging is used for large quantities. Bearings are wrapped in 5's or 10's in protective paper and then packed in cartons. To facilitate handling these cartons are available in two different sizes:

Carton type A - 19x25x16.5 cm

Carton type B - 37.5x25x16.5 cm

Packing for shipment

Cartons are then palletised on Europallets, shrink wrapped and then strapped safe transport.

Serie 600 - Microcuscinetti radiali a sfere (esecuzione aperta, 2RS, ZZ e 2RZ)
600 series - Miniature radial ball bearings (open, 2RS, ZZ and 2RZ type)

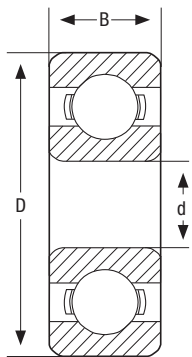

Esecuzione aperta
Open type

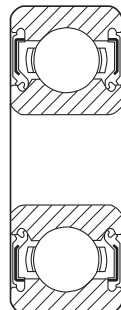

Esecuzione 2RS
2RS type

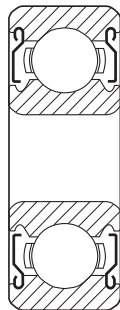

Esecuzione ZZ
ZZ type

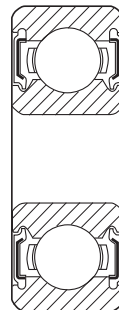

Esecuzione 2RZ
2RZ type



Tipo Type	Dimensioni Dimensions (mm)			Velocità limite Speed limit		Coefficienti di carico Load ratings (N)		Peso Weight (Kg)
	Diametro interno Inner diameter d	Diametro esterno Outer diameter D	Altezza Width B	Grasso Grease	Olio Oil	Dinamico C Dynamic C	Statico C ₀ Static C ₀	
623	3	10	4	60 000	70 000	488	146	0,0015
624	4	13	5	48 000	56 000	975	305	0,0031
634	4	16	5	43 000	50 000	1 110	380	0,0054
625	5	16	5	43 000	50 000	1 110	380	0,0050
635	5	19	6	36 000	43 000	1 720	620	0,0090
626	6	19	6	36 000	43 000	1 720	620	0,0084
607	7	19	6	38 000	45 000	1 720	620	0,0075
627	7	22	7	32 000	38 000	3 250	1 370	0,0130
608	8	22	7	36 000	43 000	3 250	1 370	0,0120
609	9	24	7	32 000	38 000	3 710	1 660	0,0140
629	9	26	8	28 000	34 000	4 620	1 960	0,0200



Cuscinetti per applicazioni "bassa rumorosità"

Serie 60.. - Cuscinetti radiali ad una corona di sfere (esecuzione aperta, 2RS, ZZ e 2RZ)

60.. series - Radial deep groove ball bearings single row (open, 2RS, ZZ and 2RZ type)

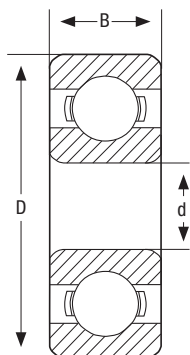

Esecuzione aperta
Open type

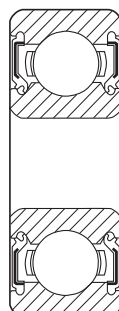

Esecuzione 2RS
2RS type

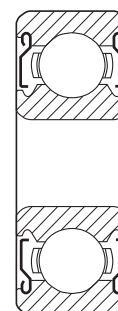

Esecuzione ZZ
ZZ type

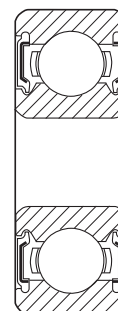

Esecuzione 2RZ
2RZ type

Tipo Type	Dimensioni Dimensions (mm)			Velocità limite Speed limit		Coefficienti di carico Load ratings (N)		Peso Weight (Kg)
	Diametro interno Inner diameter d	Diametro esterno Outer diameter D	Altezza Width B	Grasso Grease	Olio Oil	Dinamico C Dynamic C	Statico C ₀ Static C ₀	
6000	10	26	8	30 000	36 000	4 620	1 960	0,019
6001	12	28	8	26 000	32 000	5 070	2 360	0,022
6002	15	32	9	22 000	28 000	5 590	2 850	0,030
6003	17	35	10	19 000	24 000	6 050	3 250	0,039
6004	20	42	12	17 000	20 000	9 360	5 000	0,069
6005	25	47	12	15 000	18 000	11 200	6 550	0,080
6006	30	55	13	12 000	15 000	13 300	8 300	0,120
6007	35	62	14	10 000	13 000	15 900	10 200	0,160
6008	40	68	15	9 500	12 000	16 800	11 600	0,190
6009	45	75	16	9 000	11 000	20 800	14 600	0,250
6010	50	80	16	8 500	10 000	21 600	16 000	0,260
6011	55	90	18	7 500	9 000	28 100	21 200	0,390
6012	60	95	18	6 700	8 000	29 600	23 200	0,420
6013	65	100	18	6 300	7 500	30 700	25 000	0,440
6014	70	110	20	6 000	7 000	37 700	31 000	0,600
6015	75	115	20	5 600	6 700	39 700	33 500	0,640
6016	80	125	22	5 300	6 300	47 500	40 000	0,850
6017	85	130	22	5 126	6 030	51 000	42 200	0,890
6018	90	140	24	4 820	5 670	59 300	49 100	1,150
6019	95	145	24	4 590	5 400	62 500	53 000	1,200
6020	100	150	24	4 284	5 040	62 500	53 000	1,250
6021	105	160	26	4 055	4 770	74 600	64 200	1,600
6022	110	170	28	3 825	4 500	83 500	72 100	1,950
6024	120	180	28	3 672	4 320	86 700	78 500	2,050

Serie 62.. - Cuscinetti radiali ad una corona di sfere (esecuzione aperta, 2RS, ZZ e 2RZ)
62.. series - Radial deep groove ball bearings single row (open, 2RS, ZZ and 2RZ type)

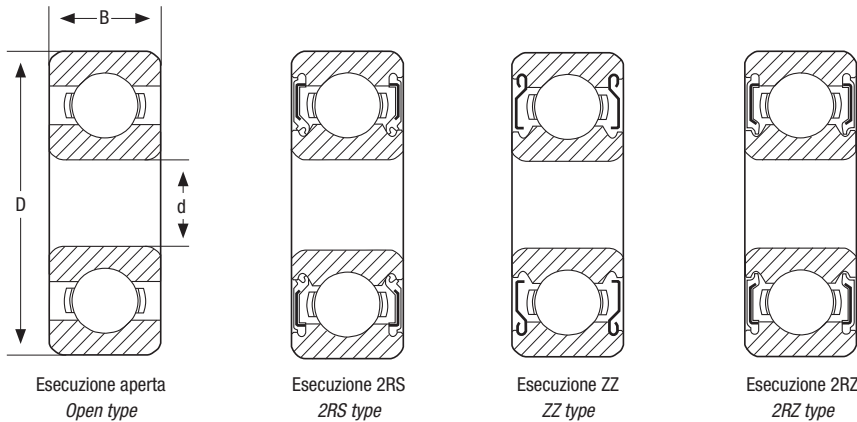

Tipo Type	Dimensioni Dimensions (mm)			Velocità limite Speed limit		Coefficienti di carico Load ratings (N)		Peso Weight (Kg)
	Diametro interno Inner diameter d	Diametro esterno Outer diameter D	Altezza Width B	Grasso Grease	Olio Oil	Dinamico C Dynamic C	Statico C ₀ Static C ₀	
6200	10	30	9	24 000	30 000	5 070	2 360	0,032
6201	12	32	10	22 000	28 000	6 890	3 100	0,037
6202	15	35	11	19 000	24 000	7 800	3 750	0,045
6203	17	40	12	17 000	20 000	9 560	4 750	0,065
6204	20	47	14	15 000	18 000	12 700	6 550	0,110
6205	25	52	15	12 000	15 000	14 000	7 800	0,130
6206	30	62	16	10 000	13 000	19 500	11 200	0,200
6207	35	72	17	9 000	11 000	25 500	15 300	0,290
6208	40	80	18	8 500	10 000	30 700	19 000	0,370
6209	45	85	19	7 500	9 000	33 200	21 600	0,410
6210	50	90	20	7 000	8 500	35 100	23 200	0,460
6211	55	100	21	6 300	7 500	43 600	29 000	0,610
6212	60	110	22	6 000	7 000	52 700	36 000	0,780
6213	65	120	23	5 300	6 300	55 900	40 500	0,990
6214	70	125	24	5 000	6 000	60 500	45 000	1,050
6215	75	130	25	4 800	5 600	66 300	49 000	1,200
6216	80	140	26	4 500	5 300	70 200	55 000	1,400
6217	85	150	28	4 284	5 040	85 400	62 800	1,800
6218	90	160	30	4 055	4 770	99 000	72 100	2,150
6219	95	170	32	3 825	4 500	111 800	79 900	2,600
6220	100	180	34	3 672	4 320	124 500	91 150	3,150
6221	105	190	36	3 443	4 050	137 300	102 000	3,700
6222	110	200	38	3 290	3 870	148 000	115 700	4,350



Cuscinetti per applicazioni "bassa rumorosità"

Serie 63.. - Cuscinetti radiali ad una corona di sfere (esecuzione aperta, 2RS, ZZ e 2RZ)

63.. series - Radial deep groove ball bearings single row (open, 2RS, ZZ and 2RZ type)

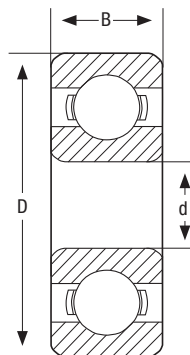

Esecuzione aperta
Open type

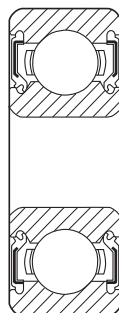

Esecuzione 2RS
2RS type

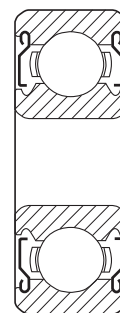

Esecuzione ZZ
ZZ type

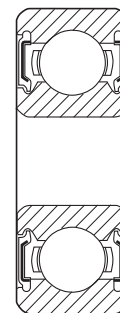

Esecuzione 2RZ
2RZ type

Tipo Type	Dimensioni Dimensions (mm)			Velocità limite Speed limit		Coefficienti di carico Load ratings (N)		Peso Weight (Kg)
	Diametro interno Inner diameter d	Diametro esterno Outer diameter D	Altezza Width B	Grasso Grease	Olio Oil	Dinamico C Dynamic C	Statico C ₀ Static C ₀	
6300	10	35	11	20 000	26 000	8 060	3 400	0,053
6301	12	37	12	19 000	24 000	9 750	4 150	0,060
6302	15	42	13	17 000	20 000	11 400	5 400	0,082
6303	17	47	14	16 000	19 000	13 500	6 550	0,120
6304	20	52	15	13 000	16 000	15 900	7 800	0,140
6305	25	62	17	11 000	14 000	22 500	11 600	0,230
6306	30	72	19	9 000	11 000	28 100	16 000	0,350
6307	35	80	21	8 500	10 000	33 200	19 000	0,460
6308	40	90	23	7 500	9 000	41 000	24 000	0,630
6309	45	100	25	6 700	8 000	52 700	31 500	0,830
6310	50	110	27	6 300	7 500	61 800	38 000	1,050
6311	55	120	29	5 600	6 700	71 500	45 000	1,350
6312	60	130	31	5 000	6 000	81 900	52 000	1,700
6313	65	140	33	4 800	5 600	92 300	60 000	2,100
6314	70	150	35	4 500	5 300	104 000	68 000	2,500
6315	75	160	37	4 300	5 000	114 000	76 500	3,000
6316	80	170	39	3 250	3 800	124 000	86 500	3,600
6317	85	180	41	3 600	4 300	133 000	96 500	4,250
6318	90	190	43	3 400	4 000	143 000	108 000	4,900
6319	95	200	45	3 443	4 050	155 900	115 700	5,650
6320	100	215	47	3 290	3 870	170 600	137 300	7,000

Serie larga 622.. - Cuscinetti radiali ad una corona di sfere (esecuzione RS e 2RS)

622.. large series - Radial ball bearings single row (RS and 2RS type)

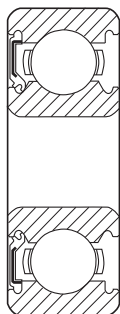

Esecuzione RS
RS type

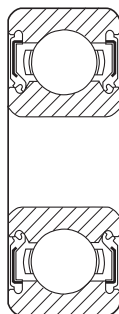

Esecuzione 2RS
2RS type



Tipo Type	Dimensioni Dimensions (mm)			Velocità limite Speed limit	Coefficienti di carico Load ratings (N)		Peso Weight (Kg)
	Diametro interno Inner diameter d	Diametro esterno Outer diameter D	Altezza Width B	Grasso Grease	Dinamico C Dynamic C	Statico C ₀ Static C ₀	
62200	10	30	14	17 000	5 070	2 360	0,040
62201	12	32	14	15 000	6 890	3 100	0,045
62202	15	35	14	13 000	7 800	3 750	0,054
62203	17	40	16	12 000	9 560	4 750	0,083
62204	20	47	18	10 000	12 700	6 550	0,130
62205	25	52	18	8 500	14 000	7 800	0,150
62206	30	62	20	7 500	19 500	11 200	0,240
62207	35	72	23	6 300	25 500	15 300	0,370
62208	40	80	23	5 600	30 700	19 000	0,440
62209	45	85	23	5 000	33 200	21 600	0,480
62210	50	90	23	4 800	35 100	23 200	0,520



Cuscinetti per applicazioni "bassa rumorosità"

Serie larga 630.. - Cuscinetti radiali ad una corona di sfere (esecuzione RS e 2RS)

630.. large series - Radial ball bearings single row (RS and 2RS type)

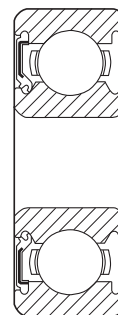

Esecuzione RS
RS type

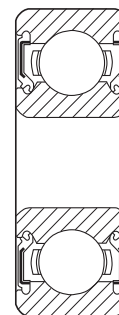

Esecuzione 2RS
2RS type

Tipo Type	Dimensioni Dimensions (mm)			Velocità limite Speed limit	Coefficienti di carico Load ratings (N)		Peso Weight Kg
	Diametro interno Inner diameter d	Diametro esterno Outer diameter D	Altezza Width B		Dinamico C Dynamic C	Statico C ₀ Static C ₀	
630/8	8	22	11	20 000	3 250	1 370	0,016
63000	10	26	12	19 000	4 620	1 960	0,025
63001	12	28	12	17 000	5 070	2 360	0,029
63002	15	32	13	14 000	5 590	2 850	0,039
63003	17	35	14	13 000	6 050	3 250	0,052
63004	20	42	16	11 000	9 360	5 000	0,086
63005	25	47	16	9 500	11 200	6 550	0,100
63006	30	55	19	8 000	13 300	8 300	0,160
63007	35	62	20	7 000	15 900	10 200	0,210
63008	40	68	21	6 300	16 800	11 600	0,260
63009	45	75	23	5 600	20 800	14 600	0,340
63010	50	80	23	5 000	21 600	16 000	0,370

Serie 160.. e 161.. - Cuscinetti radiali ad una corona di sfere (solo esecuzione aperta)
160.. and 161.. series - Radial deep groove ball bearings single row (open type only)

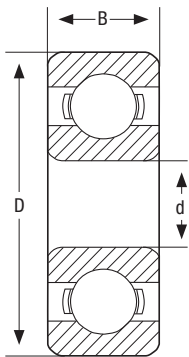

Esecuzione aperta
Open type

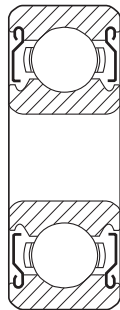

Esecuzione ZZ
ZZ type



Tipo Type	Dimensioni Dimensions (mm)			Velocità limite Speed limit		Coefficienti di carico Load ratings (N)		Peso Weight (Kg)
	Diametro interno Inner diameter d	Diametro esterno Outer diameter D	Altezza Width B	Grasso Grease	Olio Oil	Dinamico C Dynamic C	Statico C ₀ Static C ₀	
16002*	15	32	8	22 000	28 000	5 590	2 850	0,025
16003*	17	35	8	19 000	24 000	6 050	3 250	0,032
16004	20	42	8	17 000	20 000	6 890	4 050	0,050
16005	25	47	8	14 000	17 000	7 610	4 750	0,060
16006	30	55	9	12 000	15 000	11 200	7 350	0,085
16007	35	62	9	10 000	13 000	12 400	8 150	0,110
16008	40	68	9	9 500	12 000	13 300	9 150	0,130
16009	45	75	10	9 000	11 000	15 600	10 800	0,170
16010	50	80	10	8 500	10 000	16 300	11 400	0,180
16011	55	90	11	7 500	9 000	19 500	14 000	0,260
16012	60	95	11	6 700	8 000	19 900	15 000	0,280
16013	65	100	11	6 885	8 100	22 100	16 300	0,300
16014	70	110	13	6 120	7 200	28 600	24 500	0,430
16015	75	115	13	5 738	6 750	29 600	26 500	0,460
16016	80	125	14	5 355	6 300	34 400	30 900	0,600
16017	85	130	14	5 126	6 030	35 100	32 900	0,630
16018	90	140	16	4 820	5 670	42 800	38 300	0,850
16019	95	145	16	4 590	5 400	43 900	40 700	0,890
16020	100	150	16	4 284	5 040	45 300	43 200	0,910
16100*	10	28	8	28 000	34 000	4 620	1 960	0,022
16101	12	30	8	26 000	32 000	5 070	2 360	0,023

* Solo in esecuzione ZZ
ZZ type only



Cuscinetti per applicazioni "bassa rumorosità"

Serie 618.. e 619.. - Cuscinetti radiali ad una corona di sfere (esecuzione aperta, 2RS, ZZ e 2RZ)
618.. and 619.. series - Radial deep groove ball bearings single row (open, 2RS, ZZ and 2RZ type)

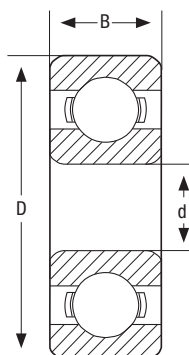

Esecuzione aperta
Open type

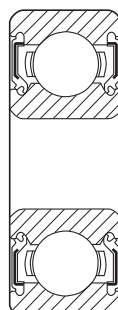

Esecuzione 2RS
2RS type

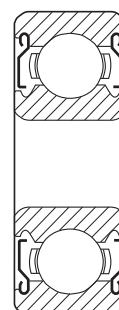

Esecuzione ZZ
ZZ type

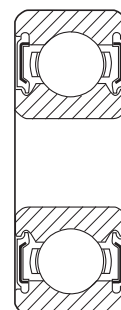

Esecuzione 2RZ
2RZ type

Tipo Type	Dimensioni Dimensions (mm)			Velocità limite Speed limit		Coefficienti di carico Load ratings (N)		Peso Weight (Kg)
	Diametro interno Inner diameter d	Diametro esterno Outer diameter D	Altezza Width B	Grasso Grease	Olio Oil	Dinamico C Dynamic C	Statico C ₀ Static C ₀	
61800	10	19	5	36 000	43 000	1 380	585	0,0055
61801	12	21	5	32 000	38 000	1 430	670	0,0063
61802	15	24	5	28 000	34 000	1 560	800	0,0074
61803	17	26	5	24 000	30 000	1 680	930	0,0082
61804	20	32	7	19 000	24 000	2 700	1 500	0,0180
61805	25	37	7	17 000	20 000	4 360	2 600	0,0220
61806	30	42	7	15 000	18 000	4 490	2 900	0,0270
61807	35	47	7	13 000	16 000	4 750	3 200	0,0300
61808	40	52	7	11 000	14 000	4 940	3 450	0,0340
61809	45	58	7	10 710	12 600	6 500	6 000	0,040
61810	50	65	7	9 945	11 700	6 800	6 700	0,052
61811	55	72	9	9 180	10 800	8 860	8 700	0,083
61812	60	78	10	8 415	9 900	11 700	11 200	0,110
61813	65	85	10	7 650	9 000	12 200	12 500	0,130
61814	70	90	10	6 885	8 100	12 200	13 000	0,140
61815	75	95	10	6 503	7 650	12 500	14 100	0,150
61816	80	100	10	6 120	7 200	12 800	14 800	0,150
61817	85	110	13	5 738	6 750	19 200	20 400	0,270
61818	90	115	13	5 355	6 300	19 200	21 600	0,280
61819	95	120	13	5 126	6 030	19 600	22 400	0,300
61820	100	125	13	4 820	5 670	19 600	23 600	0,310
61821	105	130	13	4 820	5 670	20 400	19 300	0,320
61822	110	140	16	4 284	5 040	27 600	25 500	0,600
61824	120	150	16	4 055	4 770	28 600	27 600	0,650
61826	130	165	18	3 672	4 320	36 900	42 200	0,930
61828	140	175	18	3 443	4 050	38 300	45 600	0,990
61830	150	190	20	3 290	3 870	47 900	59 800	1,400

Serie 618.. e 619.. - Cuscinetti radiali ad una corona di sfere (esecuzione aperta, 2RS, ZZ e 2RZ)
618.. and 619.. series - Radial deep groove ball bearings single row (open, 2RS, ZZ and 2RZ type)

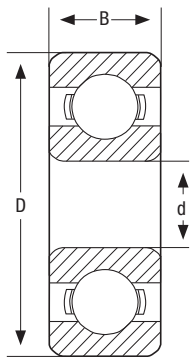

Esecuzione aperta
Open type

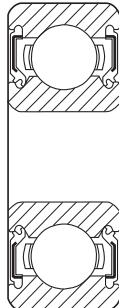

Esecuzione 2RS
2RS type

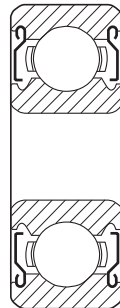

Esecuzione ZZ
ZZ type

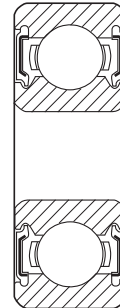

Esecuzione 2RZ
2RZ type



Tipo Type	Dimensioni Dimensions (mm)			Velocità limite Speed limit		Coefficienti di carico Load ratings (N)		Peso Weight (Kg)
	Diametro interno Inner diameter d	Diametro esterno Outer diameter D	Altezza Width B	Grasso Grease	Olio Oil	Dinamico C Dynamic C	Statico C ₀ Static C ₀	
61900	10	22	6	34 000	40 000	1 950	750	0,010
61901	12	24	6	30 000	36 000	2 250	980	0,011
61902	15	28	7	24 000	30 000	4 030	2 040	0,016
61903	17	30	7	22 000	28 000	4 360	2 320	0,018
61904	20	37	9	18 000	22 000	6 370	3 650	0,038
61905	25	42	9	16 000	19 000	6 630	4 000	0,045
61906	30	47	9	14 000	17 000	7 280	4 550	0,051
61907	35	55	10	11 000	14 000	9 560	6 200	0,080
61908	40	62	12	10 000	13 000	13 800	9 300	0,120
61909	45	68	12	9 945	11 700	13 800	10 600	0,140
61910	50	72	12	9 180	10 800	14 400	11 600	0,140
61911	55	80	13	8 415	9 900	16 200	13 800	0,190
61912	60	85	13	7 650	9 000	16 200	14 100	0,200
61913	65	90	13	7 268	8 550	17 100	15 700	0,220
61914	70	100	16	6 503	7 650	23 400	20 800	0,350
61915	75	105	16	6 120	7 200	23 800	19 000	0,370
61916	80	110	16	5 738	6 750	24 600	20 000	0,400
61917	85	120	18	5 355	6 300	31 300	29 500	0,550
61918	90	125	18	5 126	6 030	32 600	30 900	0,590
61919	95	130	18	4 820	5 670	33 200	32 900	0,610
61920	100	140	20	4 590	5 400	41 500	40 200	0,830
61921	105	145	20	4 284	5 040	43 400	43 200	0,870
61922	110	150	20	4 284	5 040	42 800	44 200	0,900
61924	120	165	22	3 825	4 500	54 200	55 900	1,200
61926	130	180	24	3 443	4 050	63 700	65 700	1,850



Cuscinetti per applicazioni "bassa rumorosità"

Serie 72.. e 73.. - Cuscinetti obliqui ad una corona di sfere (solo esecuzione aperta - gabbia in poliammide)
72.. and 73.. series - Angular contact single-row ball bearings (open type only - polyamide cage)

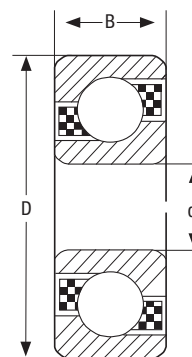

Esecuzione aperta
Open type

Tipo Type	Dimensioni Dimensions (mm)			Velocità limite Speed limit		Coefficienti di carico Load ratings (N)		Peso Weight (Kg)
	Diametro interno Inner diameter d	Diametro esterno Outer diameter D	Altezza Width B	Grasso Grease	Olio Oil	Dinamico C Dynamic C	Statico C ₀ Static C ₀	
7200	10	30	9	19 000	28 000	7 020	3 350	0,030
7201	12	32	10	18 000	26 000	7 610	3 800	0,036
7202	15	35	11	17 000	24 000	8 840	4 800	0,045
7203	17	40	12	15 000	20 000	11 100	6 100	0,065
7204	20	47	14	12 000	17 000	14 000	8 300	0,110
7205	25	52	15	10 000	15 000	15 600	10 200	0,130
7206	30	62	16	8 500	12 000	23 800	15 600	0,200
7207	35	72	17	8 000	11 000	30 700	20 800	0,280
7208	40	80	18	7 000	9 500	36 400	26 000	0,370
7209	45	85	19	6 700	9 000	37 700	28 000	0,420
7210	50	90	20	6 000	8 000	39 000	30 500	0,470
7211	55	100	21	5 600	7 500	48 800	38 000	0,620
7212	60	110	22	5 000	6 700	57 200	45 500	0,800
7301	12	37	12	17 000	24 000	10 600	5 000	0,060
7302	15	42	13	15 000	20 000	13 000	6 700	0,080
7303	17	47	14	13 000	18 000	15 900	8 300	0,110
7304	20	52	15	11 000	16 000	19 000	10 400	0,140
7305	25	62	17	9 000	13 000	26 000	15 600	0,230
7306	30	72	19	8 000	11 000	34 500	21 200	0,340
7307	35	80	21	7 500	10 000	39 000	24 500	0,450
7308	40	90	23	6 700	9 000	49 400	33 500	0,630
7309	45	100	25	6 000	8 000	60 500	41 500	0,850
7310	50	110	27	5 300	7 000	74 100	51 000	1,100
7311	55	120	29	4 800	6 300	85 200	60 000	1,400
7312	60	130	31	4 500	6 000	95 600	69 500	1,750

A richiesta disponibile con gabbia in acciaio - Under request available with steel cage

Serie 32.. e 33.. - Cuscinetti a sfere a contatto obliquo a due corone (esecuzione aperta, 2RS e ZZ - gabbia in poliammide)
32.. and 33.. series - Angular contact ball bearings double row (open, 2RS and ZZ types - polyamide cage)

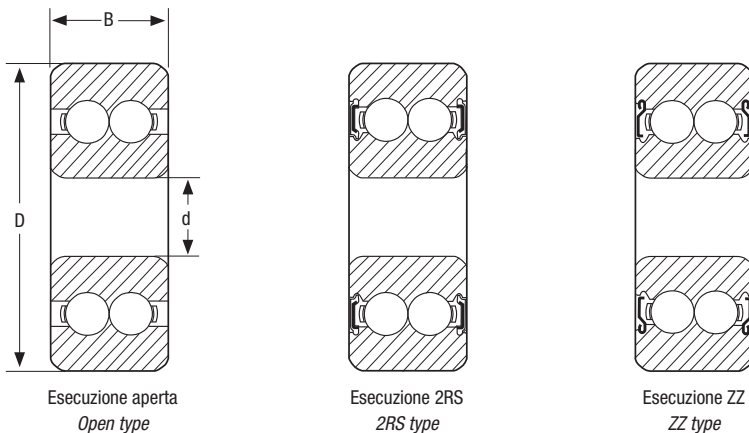

Tipo Type	Dimensioni Dimensions (mm)			Velocità limite Speed limit		Coefficienti di carico Load ratings (N)		Peso Weight (Kg)
	Diametro interno Inner diameter d	Diametro esterno Outer diameter D	Altezza Width B	Grasso Grease	Olio Oil	Dinamico C Dynamic C	Statico C ₀ Static C ₀	
3200	10	30	14,0	16 000	22 000	7 410	4 300	0,051
3201	12	32	15,9	15 000	20 000	10 100	5 600	0,058
3202	15	35	15,9	12 000	17 000	11 200	6 800	0,066
3203	17	40	17,5	10 000	15 000	14 000	8 650	0,096
3204	20	47	20,6	9 000	13 000	18 600	12 000	0,160
3205	25	52	20,6	8 000	11 000	20 300	14 000	0,180
3206	30	62	23,8	7 000	9 500	28 100	20 000	0,290
3207	35	72	27,0	6 000	8 000	37 100	27 500	0,440
3208	40	80	30,2	5 600	7 500	44 900	33 500	0,580
3209	45	85	30,2	5 000	6 700	47 500	38 000	0,630
3210	50	90	30,2	4 800	6 300	47 500	39 000	0,660
3211	55	100	33,3	4 300	5 600	57 200	67 000	1,050
3212	60	110	36,5	3 800	5 000	72 100	85 000	1,400
3302	15	42	19,0	10 000	15 000	15 100	9 150	0,130
3303	17	47	22,2	9 500	14 000	21 200	12 500	0,180
3304	20	52	22,2	8 500	12 000	22 100	14 300	0,220
3305	25	62	25,4	7 500	10 000	31 200	20 800	0,350
3306	30	72	30,2	6 300	8 500	41 000	28 500	0,530
3307	35	80	34,9	5 600	7 500	48 800	34 000	0,730
3308	40	90	36,5	5 000	6 700	59 200	43 000	0,950
3309	45	100	39,7	4 500	6 000	72 100	73 500	1,400
3310	50	110	44,4	4 000	5 300	88 000	96 500	1,950
3311	55	120	49,2	3 800	5 000	95 200	108 000	2,550
3312	60	130	54,0	3 400	4 500	112 000	127 000	3,250

A richiesta disponibile con gabbia in acciaio - Under request available with steel cage



ISB[®]

ELECTRICAL MOTORS STANDARD



©Copyright ISB[®]

È vietata la riproduzione anche parziale del contenuto di questo Catalogo Tecnico. Non si possono accettare responsabilità per eventuali errori od omissioni. Le misure non sono impegnative. Marchio registrato Italia-UE.

The reproduction, even partial, of the contained concerning this Technical Catalogue, is forbidden. Liability for possible errors and/or omissions are not accepted. Sizes are not binding. TMRegistered in Italy-UE.



ELECTRICAL MOTORS STANDARD

**CUSCINETTI PER APPLICAZIONI "BASSA RUMOROSITÀ"
BEARINGS FOR "LOW NOISE" APPLICATIONS**

1.03.11 ©Copyright **ISB**®



79991001